

# STIHL MS 341, 361

2004-05

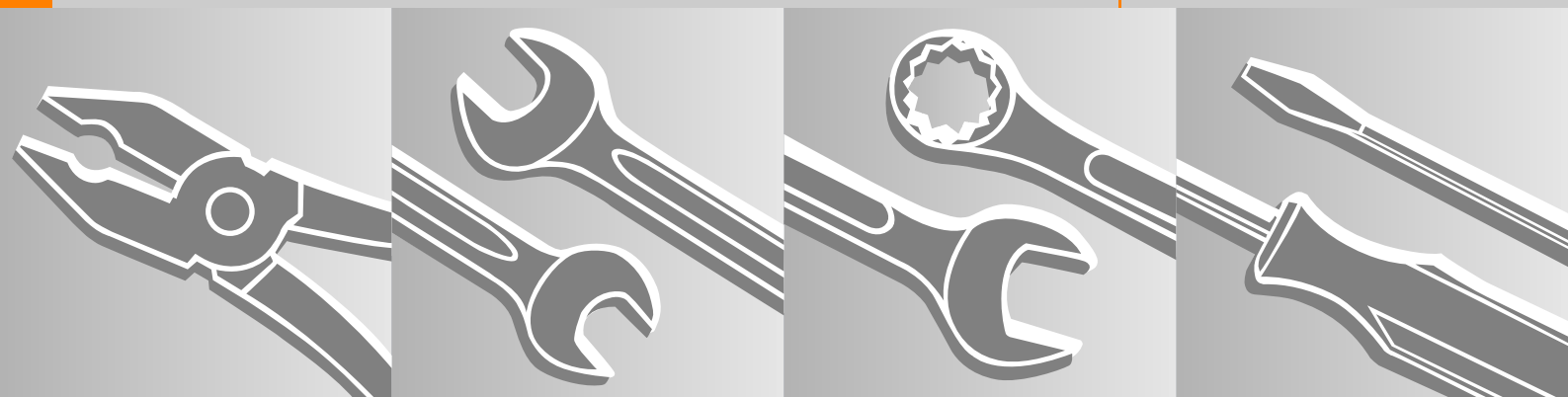

## Contents

Product: STIHL MS 341,361 Chain Saws Service Repair Workshop Manual

Full Download: <https://www.arepairmanual.com/downloads/stihl-ms-341361-chain-saws-service-repair-workshop-manual/>

<b>1. Introduction</b>	<b>3</b>	<b>6. Engine</b>	<b>32</b>	<b>9. AV System</b>	<b>65</b>
<b>2. Safety Precautions</b>	<b>4</b>	6.1 Muffler/Spark Arresting Screen	32	9.1 Repair	65
<b>3. Specifications</b>	<b>5</b>	6.2 Shroud	33	9.1.1 Spring between Front Handle and Cylinder	65
3.1 Engine	5	6.3 Leakage Test	33	9.1.2 Annular Buffer between Tank Housing and Crankcase	65
3.2 Fuel System	5	6.3.1 Preparations	34	9.1.3 Spring, Annular Buffer between Crankcase and Tank Housing	66
3.3 Ignition System	5	6.3.2 Pressure Test	35	9.1.4 Stop Buffer between Crankcase and Tank Housing	67
3.4 Chain Lubrication	5	6.3.3 Vacuum Test	35		
3.5 Tightening Torques	6	6.4 Oil Seals	36		
<b>4. Troubleshooting Chart</b>	<b>8</b>	6.5 Cylinder and Piston	37		
4.1 Clutch, Chain Drive, Chain Brake, Chain Tensioner	8	6.5.1 Removing	37		
4.2 Rewind Starter	10	6.5.2 Installing	39		
4.3 Chain Lubrication	11	6.6 Piston Rings	42		
4.4 Ignition System	12	6.7 Crankcase/ Crankshaft	43		
4.5 Carburetor	13	6.7.1 Removing	43	<b>10. Master Control / Handle System</b>	<b>67</b>
4.6 Engine	16	6.7.2 Installing	45	10.1 Switch Shaft	67
<b>5. Clutch, Chain Drive, Chain Brake and Chain Tensioner</b>	<b>17</b>	6.8 Decompression Valve	49	10.2 Throttle Trigger / Interlock Lever	68
5.1 Clutch Drum / Chain Sprocket	17	<b>7. Ignition System</b>	<b>49</b>	10.2.1 Without QuickStop Super	68
5.2 Replacing the Chain Catcher	18	7.1 Ignition Module	49	10.2.2 With QuickStop Super	69
5.3 Spiked Bumper	18	7.1.1 Ignition Timing	50	10.3 Front Handle	71
5.4 Clutch	19	7.1.2 Removing and Installing	50		
5.5 Checking Operation of Chain Brake	21	7.1.3 Testing the Ignition Module	51		
5.5.1 Removing and Installing (without QuickStop Super)	21	7.1.4 Ignition Lead / Spark Plug Boot	52	<b>11. Chain Lubrication</b>	<b>71</b>
5.5.2 Removing and Installing (with QuickStop Super)	24	7.1.5 Flywheel	53	11.1 Pickup Body / Suction Hose	71
5.5.3 Brake Cable	28	7.2 Contact Spring	54	11.2 Valve	72
5.5.4 Checking Play	28	7.3 Testing Wiring Harness	55	11.2.1 Cleaning	72
5.5.5 Adjusting Play	29	7.4 Ignition System Troubleshooting	56	11.2.2 Replacing	73
5.5.6 Checking Operation of Coasting Brake	30	<b>8. Rewind Starter</b>	<b>59</b>	11.3 Oil Pump	73
5.6 Chain Tensioner	31	8.1 General	59	11.3.1 Removing and Installing	73
5.7 Bar Mounting Studs	32	8.2 Removing and Installing	59	11.3.2 Servicing	74
		8.3 Pawls	59		
		8.4 Rope Rotor	60		
		8.5 Starter Rope / Grip	60		
		8.6 Tensioning	61		
		8.7 Segment	62		
		8.8 Starter Rope Guide Bushing	63		
		8.9 Replacing the Rewind Spring	64		

Sample of manual. Download All 110 pages at:

<https://www.arepairmanual.com/downloads/stihl-ms-341361-chain-saws-service-repair-workshop-manual/>

**STIHL**<sup>®</sup>

## Contents

<b>12. Fuel System</b>	<b>74</b>	<b>15. Special Servicing Tools</b>	<b>103</b>
12.1 Air Filter	74		
12.2 Carburetor	75		
12.2.1 Removing and Installing	75	<b>16. Servicing Aids</b>	<b>105</b>
12.2.2 Leakage Test	76		
12.3 Servicing the Carburetor	77		
12.3.1 Metering Diaphragm	77		
12.3.2 Inlet Needle	78		
12.3.3 Fixed Jet	79		
12.3.4 Pump Diaphragm	79		
12.3.5 Accelerator Pump	80		
12.4 User Adjustment	82		
12.5 Basic Setting	83		
12.6 Tank Vent	84		
12.7 Pickup Body	85		
12.8 Fuel Hose	86		
12.9 Separating Crankcase and Tank Housing	86		
12.10 Replacing the Tank Housing	88		
<b>13. Carburetor Heating</b>	<b>88</b>		
13.1 Testing	88		
13.2 Troubleshooting Chart	90		
<b>14. Handle Heating System</b>	<b>91</b>		
14.1 Troubleshooting	91		
14.2 Testing Heating Element in Rear Handle	92		
14.3 Removing and Installing	92		
14.4 Testing Heating Element in Front Handle	93		
14.5 Removing and Installing	94		
14.6 Heater Switch	95		
14.7 Generator	96		
14.7.1 Troubleshooting Chart	97		
14.7.2 Test Connections and Test Values	99		
14.8 Wiring Harness	100		
14.8.1 Without Handle and Carburetor Heating	100		
14.8.2 With Handle Heating System	100		
14.8.3 With Handle and Carburetor Heating System	101		

## 1. Introduction

This service manual contains detailed descriptions of all the typical repair and servicing procedures for this power tool.

As the design concept of models MS 341 and MS 361 is almost identical, the descriptions and servicing procedures in this manual generally apply to both models. Differences are described in detail.

You should make use of the illustrated parts lists while carrying out repair work. They show the installed positions of the individual components and assemblies.

Refer to the latest edition of the relevant parts list to check the part numbers of any replacement parts.

A fault on the machine may have several causes. To help locate the fault, consult the chapter on "Troubleshooting" and the "STIHL Service Training System".

Refer to the "Technical Information" bulletins for engineering changes which have been introduced since publication of this servicing manual. Technical information bulletins also supplement the parts list until an updated edition is issued.

The special tools mentioned in the descriptions are listed in chapter "Special Servicing Tools" of this manual. Use the part numbers to identify the tools in the "STIHL Special Tools" manual which lists all the special servicing tools currently available from STIHL.

Symbols are included in the text and pictures for greater clarity. The meanings are as follows:

In the descriptions:

- = Action to be taken as shown in the illustration (above the text)
- = Action to be taken that is not shown in the illustration (above the text)

In the illustrations:

- Pointer
- ➡ Direction of movement

📖 4.2  
Reference to another chapter, i.e. chapter 4.2 in this example.

Service manuals and technical information bulletins are intended exclusively for the use of properly equipped repair shops. They must not be passed to third parties.

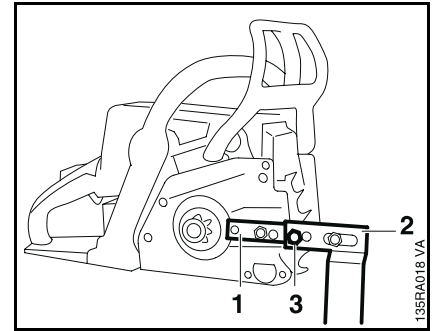

Servicing and repairs are made considerably easier if the clamp (1) 5910 890 2000 is used to mount the machine on assembly stand (2) 5910 890 3100 so that one clamp screw engages the outer 10 mm hole (3) in the assembly stand.

To service the underside of the machine (e.g. remove the front handle), turn it upside down and mount it so that one clamp screw engages the inner 10 mm hole in the assembly stand.

Pull the hand guard back against the front handle for this purpose.

### Always use original STIHL replacement parts.

They can be identified by the STIHL part number, the **STIHL** logo and the STIHL parts symbol . This symbol may appear alone on small parts.

## 2. Safety Precautions

If the engine is started up in the course of repairs or maintenance work, observe all local and country-specific safety regulations as well as the safety precautions and warnings in the instruction manual.

Gasoline is an extremely flammable fuel and can be explosive in certain conditions.

Improper handling may result in burns or other serious injuries.

### **Warning!**

Do not bring any fire, flame, spark or other source of heat near the fuel. All work with fuel must be performed outdoors only. Spilled fuel must be wiped away immediately.

### 3. Specifications

#### 3.1 Engine

	<b>MS 341</b>	<b>MS 361</b>
Displacement:	59.0 cm <sup>3</sup>	59.0 cm <sup>3</sup>
Bore:	47 mm	47 mm
Stroke:	34 mm	34 mm
Engine power to ISO 7293:	3.1 kW (4.1 bhp) at 9,500 rpm	3.4 kW (4.6 bhp) at 9,500 rpm
Max. permissible engine speed with bar and chain:	13,500 rpm	14,000 rpm
Idle speed:	2,800 rpm	
Clutch:	Centrifugal clutch without linings	
Clutch engages at:	3,500 rpm	
Crankcase leakage test at gauge pressure:	0.5 bar	
under vacuum:	0.5 bar	

---

#### 3.2 Fuel System

Carburetor leakage test at gauge pressure:	0.8 bar
Operation of tank vent at gauge pressure:	0.3 bar
Fuel:	as specified in instruction manual

---

#### 3.3 Ignition System

Air gap between ignition module and fanwheel:	0.15 – 0.3 mm
Spark plug (suppressed):	Bosch WSR 6F NGK BPMPR 7 A
Electrode gap:	0.5 mm

---

#### 3.4 Chain Lubrication

	Fully automatic, speed-controlled oil pump with rotary piston
Oil delivery rate:	5.5 – 15 cm <sup>3</sup> at 10,000 rpm

---

### 3.5 Tightening Torques

DG screws are used in polymer and light metal components. These screws form a permanent thread when they are installed for the first time. They can be removed and installed as often as necessary without impairing the strength of the screwed assembly, providing the specified tightening torque is observed.

For this reason it is **essential to use a torque wrench**.

Fastener	Thread size	For component	Torque	Remarks
			Nm	
Screw	IS-M4x8	Chain tensioner cover plate/crankcase	3.0	
Screw	IS-M4x12	Brake band/crankcase	3.0	1)
Screw	IS-P4x10	Brake cable retainer/tank housing	1.5	6)
Collar screw	IS-M8x21.5	Collar screw for guide bar	23.0	1)
Screw	IS-M4x12	Cover, chain brake/crankcase	3.0	
	IS-M10x1	Decompression valve	14.0	
Screw	IS-B4.2x9.5	Spark arresting screen/muffler	2.0	
Screw	IS-M4x12	Generator	3.0	1)5)
Screw	IS-P5x16	Front handle/plug, AV spring	4.0	
Screw	IS-P6x19	Front handle/plug, AV spring	7.0	5)
Screw	IS-P6x21.5	Front handle/tank housing, top right	7.0	3)
Screw	IS-P6x32.5	Front handle/tank housing, top right	5.0	4)
Screw	IS-P6x19	Front handle/tank housing, bottom	7.0	3)
Screw	IS-P6x21.5	Front handle/tank housing, bottom	5.0	4)
Screw	IS-M5x35	Handschutz/fan housing/crankcase	6.0	
Nut	M5	Shroud/stud, cylinder	3.0	
Screw	IS-P6x21.5	Chain catcher/crankcase/bearing plug	6.0	
Screw	IS-M5x16	Spiked bumper/crankcase	8.0	
Screw	IS-M5x12	Spiked bumper/crankcase/lock nut	8.0	
Screw	IS-M5x25	Crankcase, sprocket side/fan side	10.0	
Screw	IS-M5x16	Bearing plug/cylinder	10.0	2)
Screw	IS-M5x20	Fan housing/crankcase	6.0	
Carrier	M12x1L	Carrier/crankshaft	50.0	

#### Remarks:

- 1) Loctite 243, medium strength
- 2) Loctite 270, high strength
- 3) aluminium
- 4) polymer
- 5) only version with handle heating
- 6) only version with QuickStop Super

Fastener	Thread size	For component	Torque	Remarks
			Nm	
Screw	IS-M4x16	Annular buffer/crankcase	3.5	1)
Collar screw	IS-P6x27	Annular buffer/tank housing	6.0	
Screw	IS-M5x16	Muffler/crankcase	10.0	2)
Screw	IS-M5x16	Muffler/cylinder	10.0	
Nut	M12x0.75	Switch/handle housing		5)
Nut	M8x1	Flywheel/crankshaft	33.0	
Screw	IS-M4x8	Side plate/crankcase	3.0	
Screw	IS-M5x8.5	Stud/cylinder	1.4	2)
Collar nut	M5	Carburetor/collar screw	3.5	
Screw	IS-M5x25	Cylinder/crankcase	10.0	
	M14x1.25	Spark plug	25.0	
Screw	IS-M5x20	Ignition module/crankcase	8.0	
Screw	IS-M4x12	Oil pump/crankcase	3.0	

**Remarks:**

- 1) Loctite 243, medium strength
- 2) Loctite 270, high strength
- 5) Version with handle heating only

Use the following procedure when refitting a DG screw in an existing thread:

Place the screw in the hole and rotate it counterclockwise until it drops down slightly.  
Tighten the screw clockwise to the specified torque.

This procedure ensures that the screw engages properly in the existing thread and does not form a new thread and weaken the assembly.

**Note:**

Power screwdriver setting for polymer: DG screws max. 500 rpm

**4. Troubleshooting Chart**  
**4.1 Clutch, Chain Drive, Chain Brake, Chain Tensioner**

Condition	Cause	Remedy
Saw chain stops under load at full throttle	Clutch shoes badly worn	Install new clutch
	Clutch drum badly worn	Install new clutch drum
	Brake band stuck	Check freedom of movement and function of brake band.
Saw chain rotates at idle speed	Engine idle speed too high	Readjust with idle speed screw ( <b>LA</b> ) (counterclockwise)
	Clutch springs stretched or fatigued	Replace the clutch springs or install new clutch
	Clutch spring hooks broken	Replace the clutch springs
Loud noises	Clutch springs stretched or fatigued	Replace all clutch springs
	Needle cage damaged	Fit new needle cage
	Clutch shoe retainer broken	Fit new retainer
	Clutch shoes and carrier worn	Install new clutch
Chain sprocket wears rapidly	Chain not properly tensioned	Tension chain as specified
	Wrong chain pitch	Fit chain of correct pitch
	Insufficient chain lubrication	Check chain lubrication
	Chain sprocket worn	Fit new chain sprocket

Condition	Cause	Remedy
Saw chain does not stop immediately when brake is activated	Brake spring stretched or broken	Fit new brake spring
	Brake band stretched, worn or broken	Fit new brake band
	Clutch drum worn	Fit new clutch drum
Saw chain does not stop immediately when coasting brake is activated (only versions with QuickStop Super)	Brake cable play incorrect	Readjust brake cable play (free travel)
	Brake cable stretched or broken	Fit new brake cable
	Parts of activating mechanism stiff	Clean or replace parts of activating mechanism
	Chain brake spring stretched or broken	Fit new brake spring
	Brake band stretched, worn or broken	Fit new brake band

## 4.2 Rewind Starter

Condition	Cause	Remedy
Starter rope broken	Rope pulled out too vigorously as far as stop or over edge, i.e. not vertically	Fit new starter rope
	Normal wear	Fit new starter rope
Starter rope does not rewind	Rewind spring broken	Fit new rewind spring
	Spring overtensioned – no reserve when rope is fully extended	Fit new rewind spring
	Very dirty or corroded	Clean or replace rewind spring
Starter rope can be pulled out almost without resistance (crankshaft does not turn)	Guide peg on pawls or pawls themselves are worn	Fit new pawls
	Spring clip fatigued	Fit new spring clip
Starter rope is difficult to pull and rewinds very slowly	Starter mechanism is very dirty	Thoroughly clean complete starter mechanism
	Lubricating oil on rewind spring becomes viscous at very low outside temperatures (spring windings stick together)	Coat rewind spring with a little standard solvent-based degreasant (containing no chlorinated or halogenated hydrocarbons), then pull rope carefully several times until normal action is restored

### 4.3 Chain Lubrication

In the event of trouble with the chain lubrication system, check and rectify other sources of faults before disassembling the oil pump.

Condition	Cause	Remedy
Chain receives no oil	Oil tank empty	Fill up with oil
	Oil inlet hole in guide bar is blocked	Clean oil inlet hole
	Intake hose or pickup body clogged or intake hose ruptured	Fit new intake hose and pickup body
	Sealing ring between oil pump and crankcase faulty	Remove oil pump, fit new sealing ring and reinstall pump
	Valve in oil tank blocked	Clean or replace valve
	Teeth on pump piston and/or worm worn	Install new oil pump
Machine losing chain oil	Sealing ring between oil pump and crankcase faulty	Remove oil pump, fit new sealing ring and reinstall pump
	Oil pump damaged or worn	Install new oil pump
Oil pump delivers insufficient oil	Adjusting screw and/or control edge on pump piston worn	Fit new adjusting screw and/or oil pump
	Oil pump worn	Install new oil pump

## 4.4 Ignition System

### Warning!

Exercise extreme caution while carrying out maintenance and repair work on the ignition system. The high voltages which occur can cause serious or fatal accidents!

Condition	Cause	Remedy
Engine runs roughly, misfires, temporary loss of power	Spark plug boot is loose	Press boot firmly onto spark plug and fit new spring if necessary
	Spark plug sooted, smeared with oil	Clean the spark plug or replace if necessary
	Incorrect air gap between ignition module and flywheel	Set air gap correctly
	Flywheel cracked or has other damage or pole shoes have turned blue	Install new flywheel
	Ignition timing wrong, flywheel out of adjustment, key in flywheel has sheared off	Install new flywheel
	Weak magnetization in flywheel – pole shoes have turned blue	Install new flywheel
No spark		Check operation of Master Control lever and ignition module
No spark		Faulty insulation on ignition lead or short circuit wire. Use ohmmeter to check ignition lead for break. If break is detected or high resistance measured, fit a new ignition lead
	Check operation of spark plug. Inspect Master Control lever, ignition coil/lead for damage insulation and leakage current	Clean or replace spark plug, replace faulty parts of ignition system
	Crankcase damaged (cracks)	Replace crankcase

## 4.5 Carburetor

Condition	Cause	Remedy
Carburetor floods; engine stalls	Inlet needle not sealing. Foreign matter in valve seat or cone damaged	Remove and clean or replace the inlet needle, clean the fuel tank, pickup body and fuel line if necessary
	Inlet control lever sticking on spindle	Free off inlet control lever
	Helical spring not located on nipple of inlet control lever	Remove the inlet control lever and refit it correctly
	Perforated disc on diaphragm is deformed and presses constantly against the inlet control lever	Fit a new metering diaphragm
	Inlet control lever too high (relative to correct installed position)	Set inlet control lever flush with top edge of housing
Poor acceleration	Idle jet too lean	Rotate low speed screw ( <b>L</b> ) counterclockwise (richer), no further than stop
	Main jet too lean	Rotate high speed screw ( <b>H</b> ) counterclockwise (richer), no further than stop
	Inlet control lever too low (relative to correct installed position)	Set inlet control lever flush with top edge of housing
	Inlet needle sticking to valve seat	Remove inlet needle, clean and refit
	Diaphragm gasket leaking	Fit new diaphragm gasket
	Metering diaphragm damaged or shrunk	Fit new metering diaphragm
	Impulse hose damaged or kinked	Fit new impulse hose

Condition	Cause	Remedy
Engine will not idle, idle speed too high	Throttle shutter opened too wide by idle speed screw ( <b>LA</b> )	Reset idle speed screw ( <b>LA</b> ) correctly
	Oil seals/crankcase leaking	Seal or replace oil seals/crankcase
Engine stalls at idle speed	Idle jet bores or ports blocked	Clean the carburetor
	Idle jet too rich or too lean	Set low speed screw ( <b>L</b> ) correctly
	Setting of idle speed ( <b>LA</b> ) incorrect – throttle shutter completely closed	Set idle speed screw ( <b>LA</b> ) correctly
	Small plastic plate in valve jet does not close	Clean or renew valve jet

Condition	Cause	Remedy
Engine speed drops quickly under load – low power	Air filter dirty	Clean the air filter
	Throttle shutter not opened fully	Check linkage
	Tank vent faulty	Clean tank vent or replace if necessary
	Fuel pickup body dirty	Clean the pickup body, fit a new filter
	Fuel strainers dirty	Replace the fuel strainers
	Leak in fuel line between tank and fuel pump	Seal connections or install a new fuel line
	Setting of high speed screw ( <b>H</b> ) too rich	Rotate high speed screw ( <b>H</b> ) clockwise (leaner), no further than stop
	Main jet bores or ports blocked	Clean the carburetor
	Pump diaphragm damaged or fatigued	Fit new pump diaphragm
Impulse hose damaged or kinked	Fit new impulse hose	

## 4.6 Engine

Always check and, if necessary, repair the following parts before looking for faults on the engine:

- Air filter
- Fuel system
- Carburetor
- Ignition system

Condition	Cause	Remedy
Engine does not start easily, stalls at idle speed, but operates normally at full throttle	Oil seals in crankcase damaged	Replace the oil seals
	Crankcase leaking or damaged (cracks)	Seat or replace the crankcase
Engine does not deliver full power or runs erratically	Piston rings worn or broken	Replace piston rings
	Muffler / spark arresting screen carbonized	Clean the muffler (inlet and exhaust), replace spark arresting screen, replace muffler if necessary
	Air filter element dirty	Replace air filter element
	Fuel / impulse hose severely kinked or damaged	Fit new hoses or position them free from kinks
	Decompression valve sticking	Replace the decompression valve
Engine overheating	Insufficient cylinder cooling. Air inlets in fan housing blocked or cooling fins on cylinder very dirty	Thoroughly clean all cooling air openings and the cylinder fins

## 5. Clutch, Chain Drive, Chain Brake and Chain Tensioner

### 5.1 Clutch Drum / Chain Sprocket

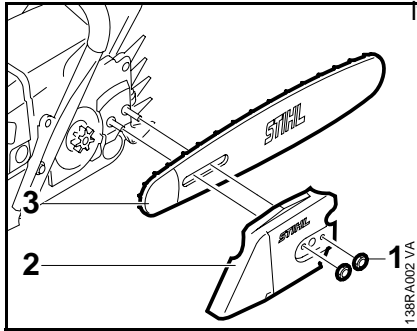

Wear work gloves to protect your hands from injury.

- Unscrew the hex nuts (1).
- Remove the chain sprocket cover (2).
- Remove the bar (3) and chain.

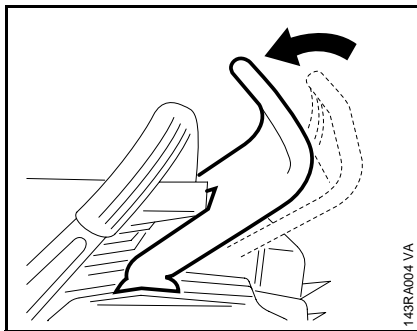

- Disengage the chain brake by pulling the hand guard towards the front handle.

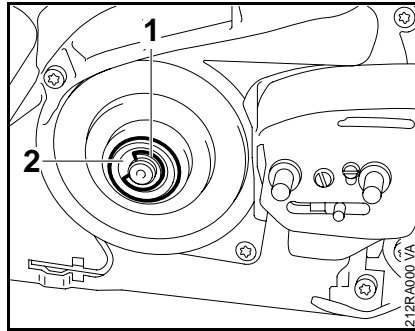

- Remove the E-clip (1).
- Remove the washer (2).

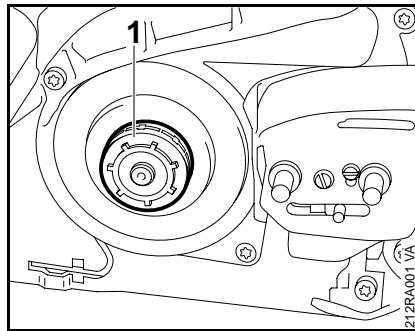

- Remove the rim sprocket (1).

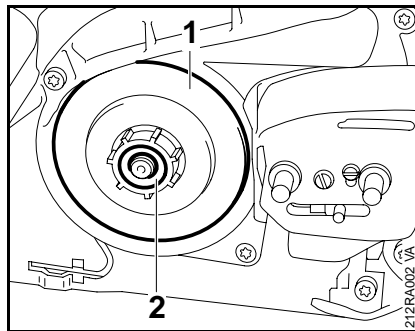

- Remove the clutch drum (1) with needle cage (2).
- Examine the needle cage for signs of damage.

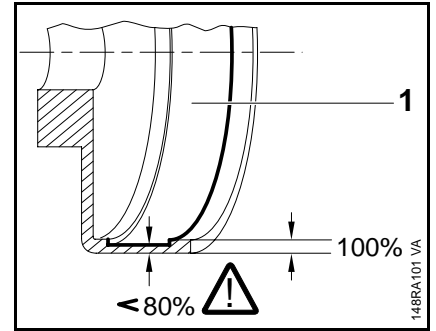

- Inspect the clutch drum (1).

If there are signs of serious wear on the inside diameter of the clutch drum (1), check the remaining wall thickness. If it is less than about 80% of the original thickness, fit a new clutch drum.

If the clutch drum has to be replaced, also check the brake band –  5.5.1 or 5.5.2.

Reassemble in the reverse sequence.

## 5.2 Replacing the Chain Catcher

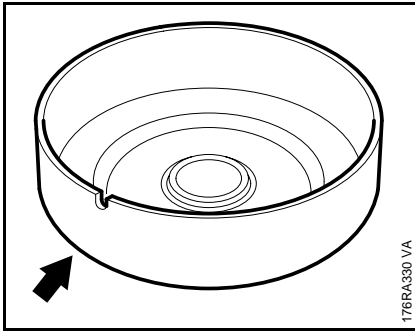

Clean stub of crankshaft. Wash needle cage, examine it for damage and replace if necessary. Lubricate needle cage with STIHL multi-purpose grease – 16.

- Rotate clutch drum/chain sprocket and apply slight pressure at the same time until the oil pump drive spring engages the notch (see arrow).

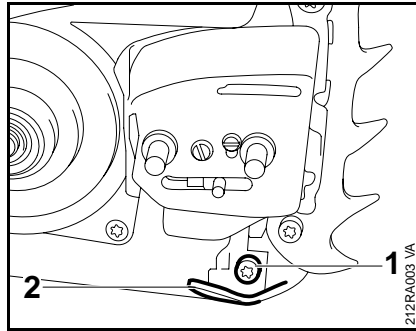

- Remove the chain sprocket cover – 5.1

- Take out the screw (1).
- Remove the chain catcher (2).

Reassemble in the reverse sequence.

## 5.3 Spiked Bumper

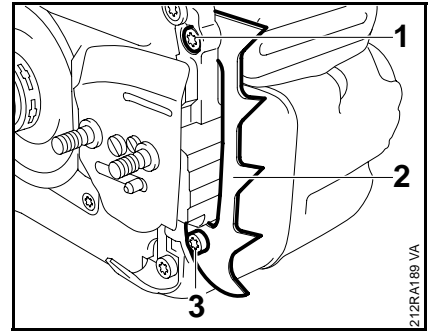



- Remove the chain sprocket cover, bar and chain – 5.1

- Hold the self-locking nut steady and take out the screw (1).
- Take out the screw (3).
- Remove the spiked bumper (2).

Reassemble in the reverse sequence.

## 5.4 Clutch

- Troubleshooting chart –  4.1
- Remove the clutch drum/chain sprocket –  5.1

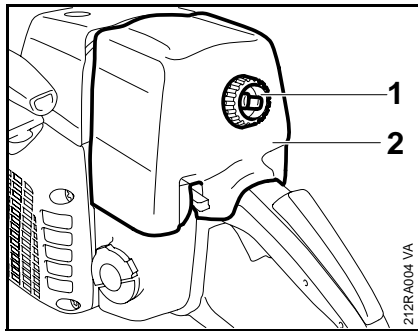

- Release twist lock (1).
- Remove carburetor box cover (2) to the rear.

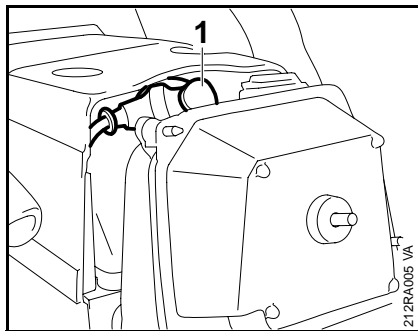

- Pull the boot (1) off the spark plug.
- Unscrew the spark plug.

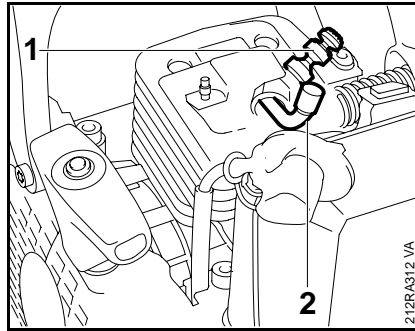

- Remove the shroud –  6.2
- Close the decompression valve (1), if fitted.
- Push the locking strip (1) 0000 893 5903 into the spark plug hole so that "OBEN-TOP" faces up.

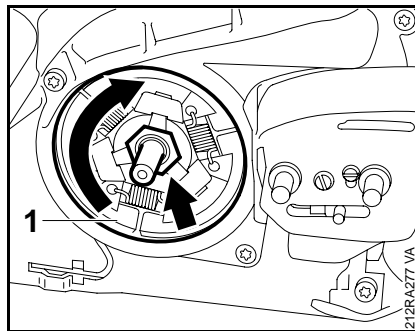

- Unscrew the clutch (1) from the crankshaft clockwise (left-hand thread).

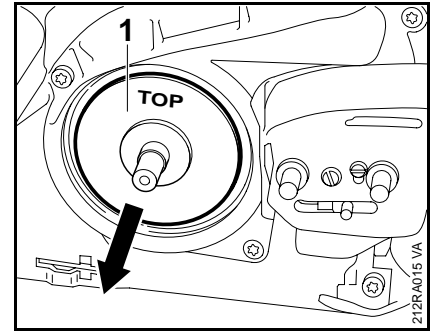

- Remove the cover washer (1) and clean it if necessary.

### Disassembling the clutch

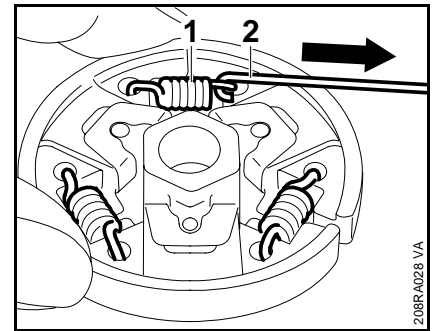

- Use hook (2) 5910 890 2800 to remove the clutch springs (1).

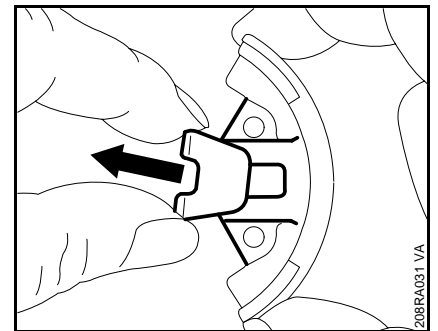

- Pull the clutch shoes off the carrier.
- Pull the retainers off the clutch shoes.

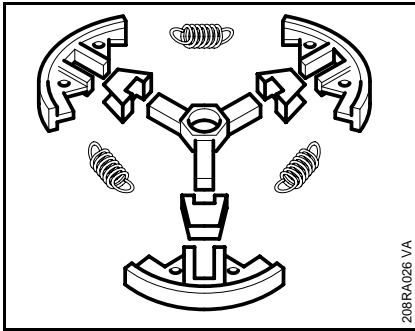

208RA026 VA

- Clean all parts – 16.
- Replace any damaged parts.

### Assembling the clutch

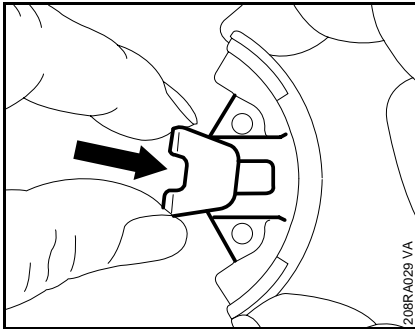

208RA029 VA

- Slip the retainers onto the clutch shoes.

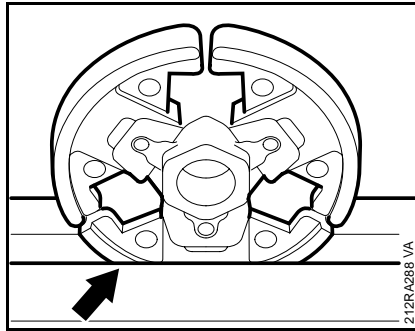

212RA0288 VA

- Clamp the clutch in a vise.

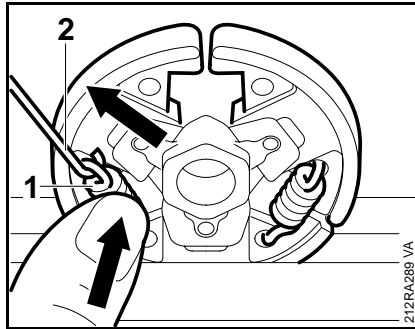

212RA288 VA

- Attach one end of each spring (1) to the clutch shoes.
- Use the hook (2) 5910 890 2800 to attach other end of the spring and press it firmly into the clutch shoe.

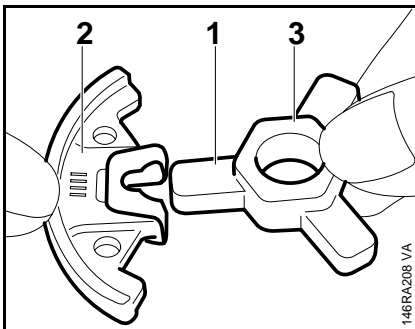

146RA208 VA

- Fit the clutch shoes over the arms (1) of the clutch carrier so that the series number (2) is on the same side as the longer hexagon (3).

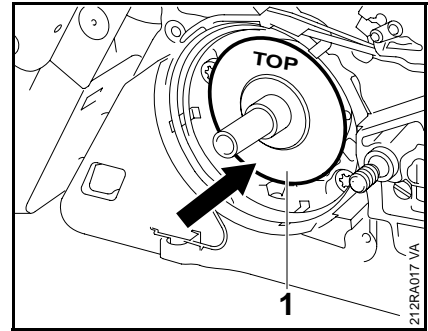

212RA017 VA

- Fit the cover washer (1) on the crankshaft so that "TOP" faces outward.

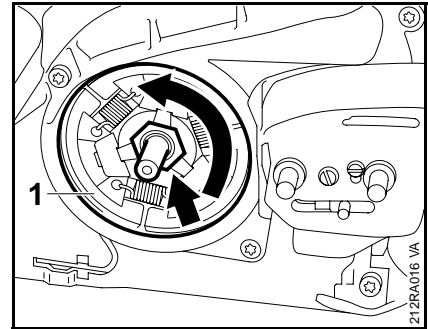

212RA016 VA

- Screw home the clutch (1), hexagon (arrow) facing outward, and tighten it down firmly – 3.5
- Remove locking strip from the cylinder.

Reassemble all other parts in the reverse sequence.

## 5.5 Checking Operation of Chain Brake

The chain brake is one of the most important safety devices on the chainsaw. Its efficiency is measured in terms of the chain braking time, i.e. the time that elapses between activating the brake and the saw chain coming to a complete standstill. The shorter the braking time, the better the efficiency and protection offered against being injured by the rotating chain.

Contamination (with chain oil, chips, fine particles of abrasion, etc.) and smoothing of the friction surfaces of the brake band and clutch drum impair the coefficient of friction. This, in turn, reduces the frictional forces and thus prolongs the braking time. A fatigued or stretched brake spring has the same negative effect.

- Start the engine.
- With the chain brake activated (locked), open the throttle wide for a brief period (max. 3 seconds) – the chain must not rotate.
- With the chain brake released, open the throttle wide and activate the brake manually – the chain must come to an abrupt stop.



The braking time is in order if deceleration of the saw chain is imperceptible to the eye.

If the chain brake does not operate properly, see troubleshooting chart –  4.1.

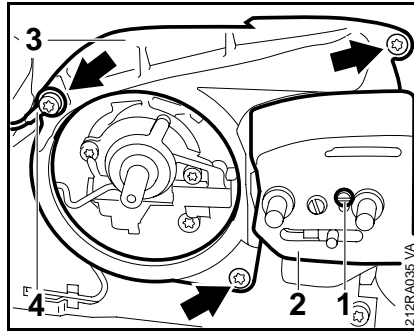
### 5.5.1 Removing and Installing (without QuickStop Super)



#### Removing

- Troubleshooting chart –  4.1
- Remove the clutch drum –  5.1
- Take out the screw (1).
- Remove the side plate (2).
- Take out the screws (arrows).
- On machines with carburetor or carburetor/handle heating, remove the ground wire (4).
- Remove the cover (3).
- Engage the chain brake by pushing the hand guard away from the front handle.

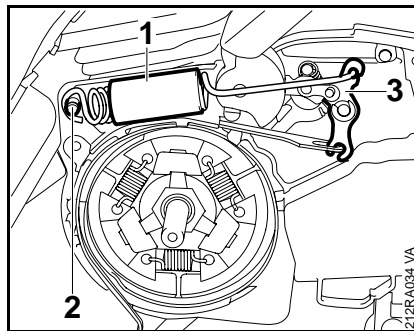

- Carefully ease the brake spring (1) off the anchor pin (2).
- Remove the brake spring (1) from the brake lever (3).

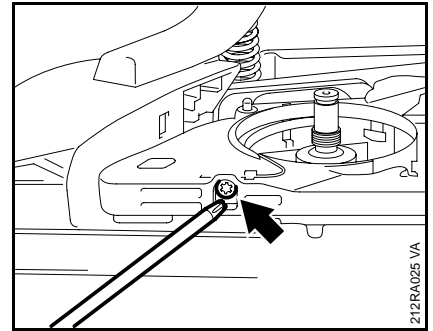

- Take out the screw (arrow).

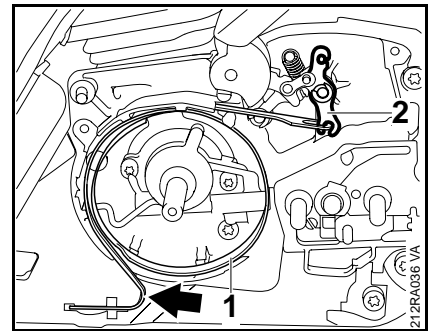

- Pry the brake band (1) out of the crankcase (arrow).
- Disconnect the brake band from the brake lever (2).

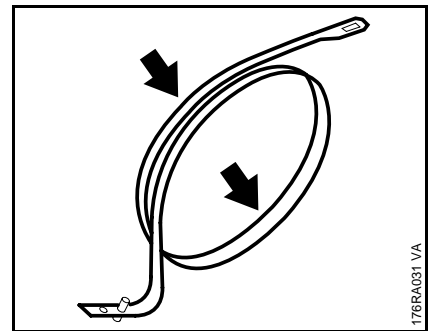

Install a new brake band if there are noticeable signs of wear (large areas on inside diameter and/or parts of outside diameter) and its remaining thickness is less than 0.6 mm.

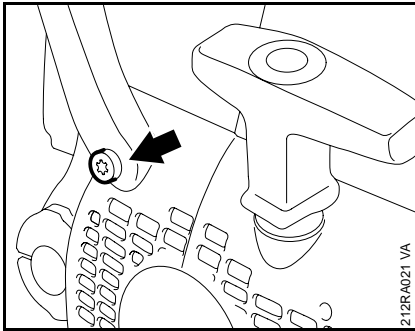

- Take out the screw (arrow).

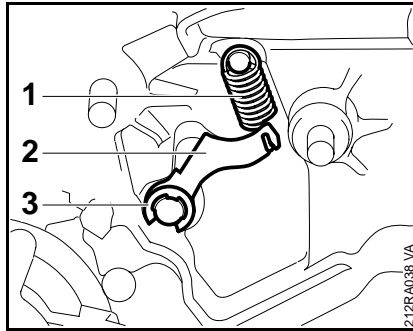

- Disconnect the spring (1).
- Remove the E-clip (3).
- Remove the lever (2) with spring (1).

Clean all disassembled parts in standard solvent-based degreasant containing no chlorinated or halogenated hydrocarbons. Inspect parts and replace if damaged.

If the groove in the brake spring anchor pin is worn, follow the steps below to install a new pin:

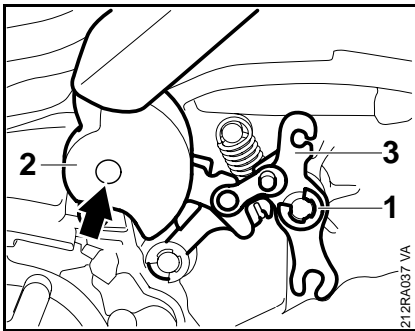

- Remove the E-clip (1).
  - Pry the hand guard (2) together with the brake lever (3) off the pivot pin (arrow).
- Pull the lever out of the hand guard.

Do not drive out the pin in the other direction as this would damage the annular bead which was formed in the crankcase bore when the pin was originally installed. In such a case neither the new anchor pin nor the brake spring would locate properly. Furthermore, the crankcase could be damaged in this way and possibly impair correct operation of the chain brake.

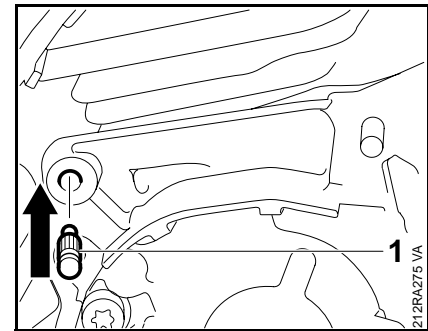

### Installing

- Before installing the new pin, coat its knurled shank with Loctite –  16.
- Position the new pin (1) in the bore so that the knurling on the pin meshes with the existing knurling in the bore. Turn pin back and forth as necessary.

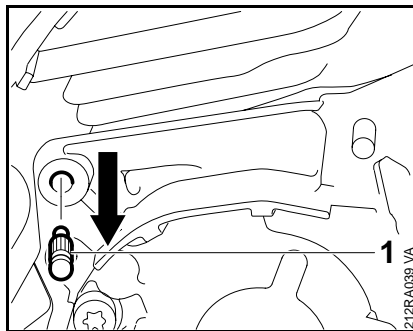

- Remove the cylinder –  6.5.1
- Use a suitable punch to drive the anchor pin (1) out of the crankcase, from the inside outwards.

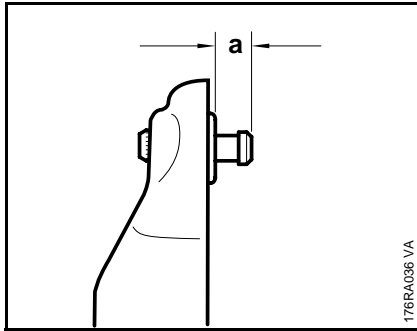

176RA036 VA

- Carefully tap home the pin squarely to obtain dimension "a" (about 4.3–4.7 mm).

– Install the cylinder – 6.5.2

Coat all sliding and bearing points with STIHL multipurpose grease – 16.

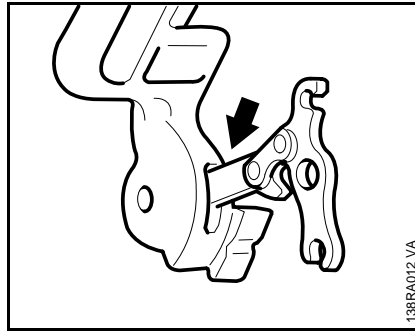

138RA012 VA

- Insert the lever in the side of the hand guard bearing boss.

Check that lever is installed correctly.

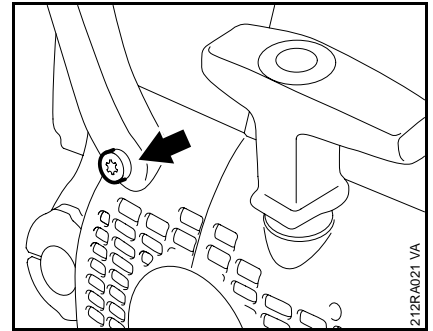

212RA021 VA

- Fit the screw (arrow) and tighten it down firmly – 3.5.

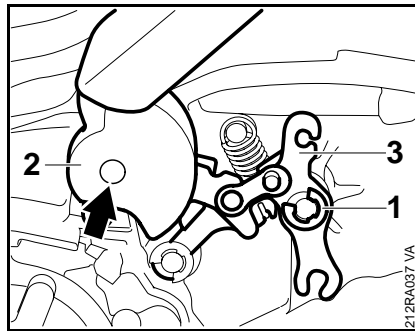

212RA037 VA

- Position bearing boss (arrow) of hand guard (2) against the pivot pin and fit the other side of the hand guard over the fan housing.

- Press the hand guard (2) carefully downward, and push the brake lever (3) onto its pivot pin at the same time.

- Fit the E-clip (1).

Coat all sliding and bearing points with STIHL multipurpose grease – 16.

Do not lubricate the brake band.

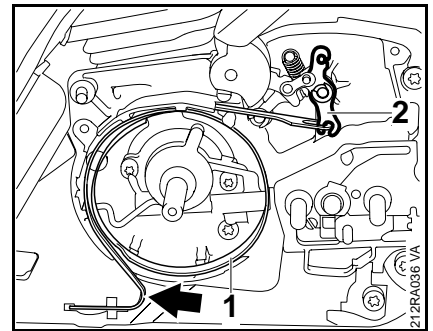

212RA036 VA

- Attach the brake band (1) to the brake lever (2) and then push it into the slot in the crankcase (arrow).

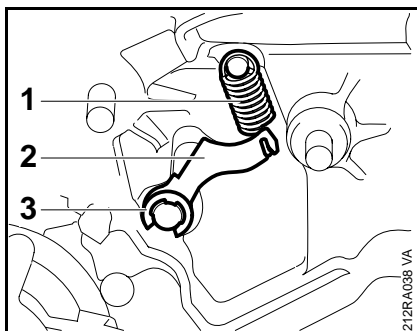

212RA038 VA

- Fit the lever (2).
- Fit the E-clip (3).
- Attach the spring (1).

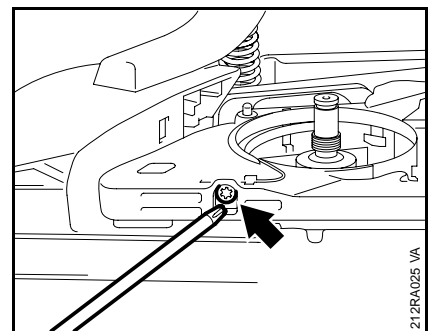

212RA025 VA

- Fit the screw (arrow) and tighten it down firmly – 3.5

## 5.5.2 Removing and Installing (with QuickStop Super)

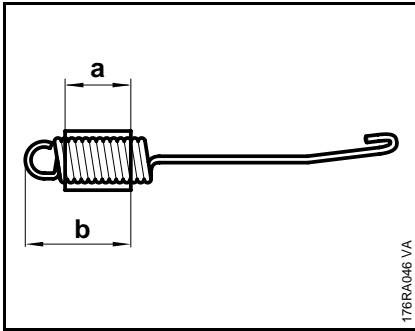

- Turns of brake spring must be tightly against one another in the relaxed condition. If this is not the case, replace the brake spring.

Check correct position of protective tube:

a = 31 mm

b = 44 mm

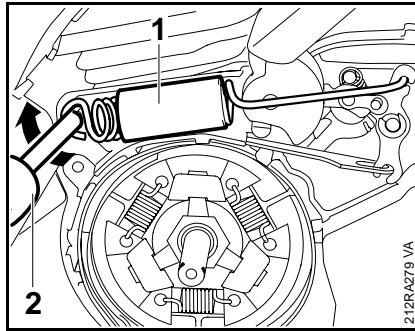

- Use the assembly tool 1117 890 0900 (2) to attach the brake spring (1) to the anchor pin (arrow).

Reassemble all other parts in the reverse sequence.

- Check operation of chain brake – 5.5

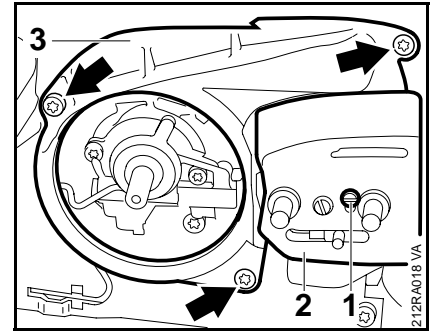

### Removing

- Troubleshooting chart – 4.1
- Remove the clutch drum – 5.1
- Take out the screw (1).
- Remove the side plate (2).
- Take out the screws (arrows).
- Remove the cover (3).
- Engage the chain brake by pushing the hand guard away from the front handle.

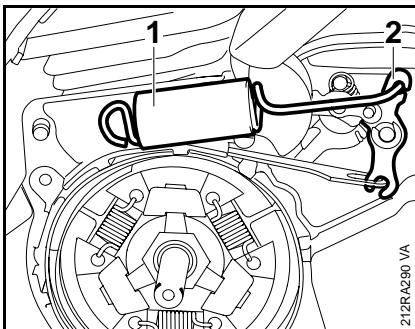

- Hook the brake spring (1) to the brake lever (2).

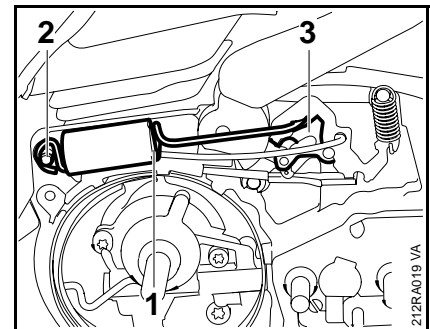

- Carefully ease the brake spring (1) off the anchor pin (2).
- Remove the brake spring (1) from the brake lever (3).

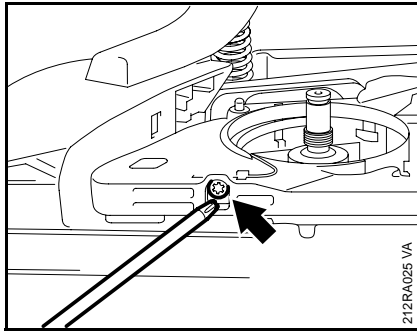

- Take out the screw (arrow).

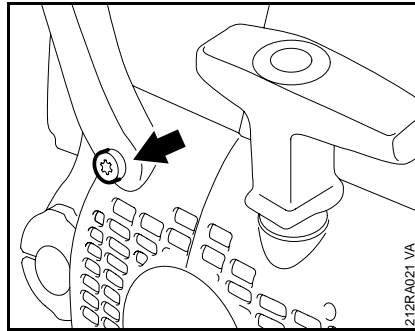

- Take out the screw (arrow).

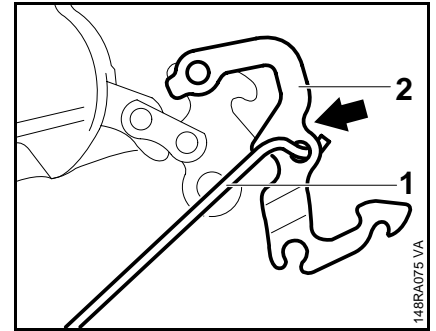

- Disconnect the brake cable (1) from the brake lever (2).
- Pull the brake lever out of the hand guard.

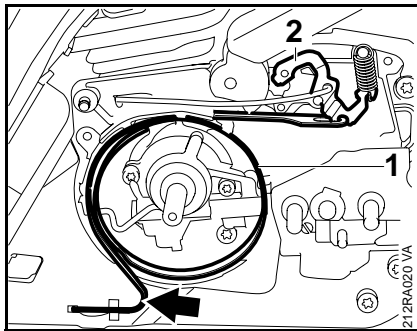

- Pry the brake band (1) out of the crankcase (arrow).
- Disconnect the brake band from the brake lever (2).

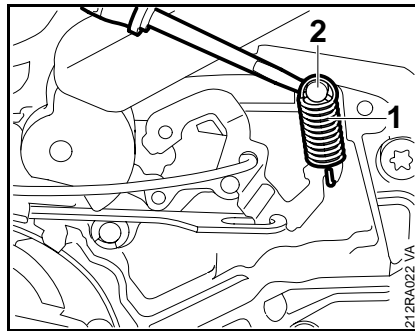

- Carefully pry the spring (1) off the pivot pin (2).

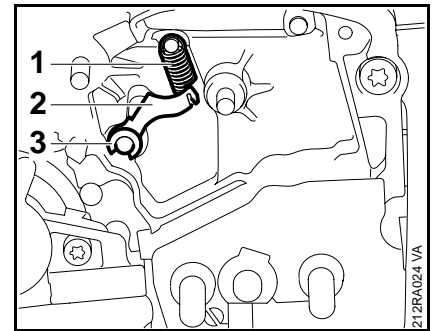

- Disconnect the spring (1).
- Remove the E-clip (3).
- Remove the lever (2) with spring (1).

Clean all disassembled parts in standard solvent-based degreasant containing no chlorinated or halogenated hydrocarbons. Inspect parts and replace if damaged.

If the groove in the brake spring anchor pin is worn, follow the steps below to install a new pin:

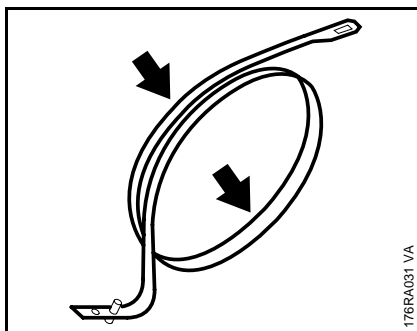

Install a new brake band if there are noticeable signs of wear (large areas on inside diameter and/or parts of outside diameter) and its remaining thickness is less than 0.6 mm.

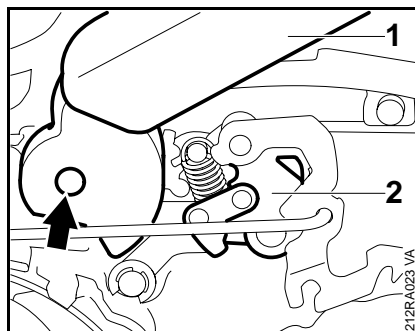

- Pry the hand guard (1) with brake lever (2) off the pivot pin (arrow).

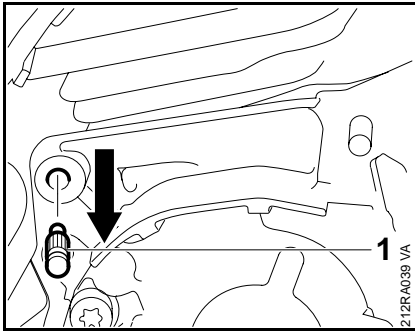

– Remove the cylinder – 6.5.1

- Use a suitable punch to drive the anchor pin (1) out of the crankcase, from the inside outwards.

Do not drive out the pin in the other direction as this would damage the annular bead which was formed in the crankcase bore when the pin was originally installed. In such a case neither the new anchor pin nor the brake spring would locate properly. Furthermore, the crankcase could be damaged in this way and possibly impair correct operation of the chain brake.

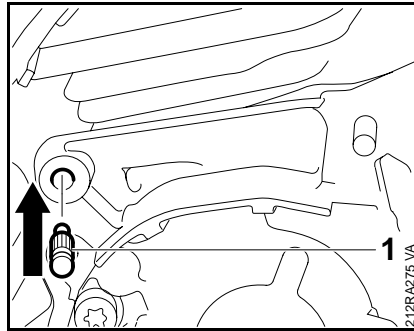

### Installing

- Before installing the new pin, coat its knurled shank with Loctite – 16.
- Position the new pin (1) in the bore so that the knurling on the pin meshes with the existing knurling in the bore. Turn pin back and forth as necessary.

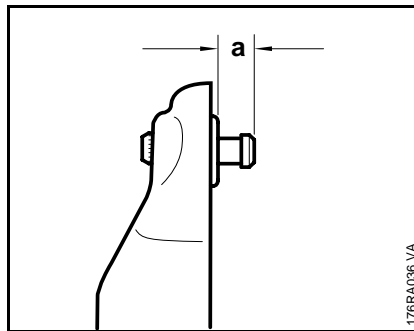

- Carefully tap home the pin squarely to obtain dimension "a" (about 4.3–4.7 mm).

– Install the cylinder – 6.5.2

Coat all sliding and bearing points with STIHL multipurpose grease – 16.

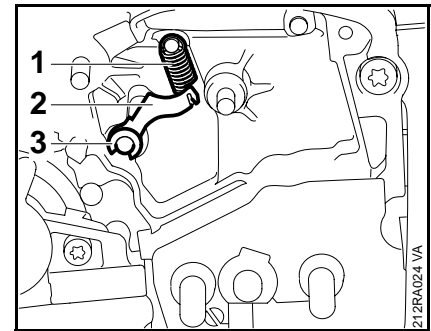

- Fit the lever (2).
- Fit the E-clip (3).
- Fit the spring (1).

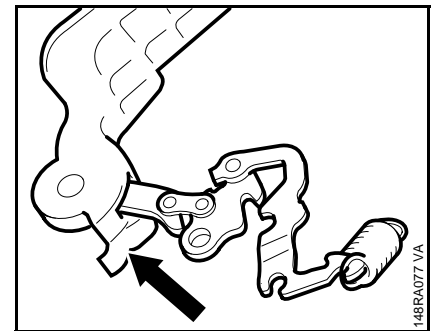

- Insert the lever in the side (arrow) of the hand guard bearing boss.

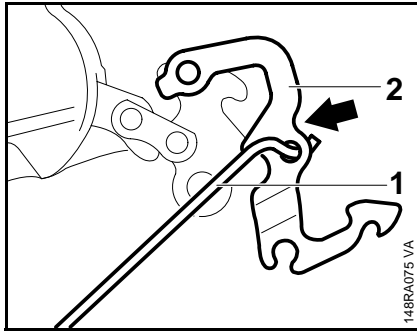

- Attach the coasting brake cable (1) to the hole (arrow) in the brake lever (2).

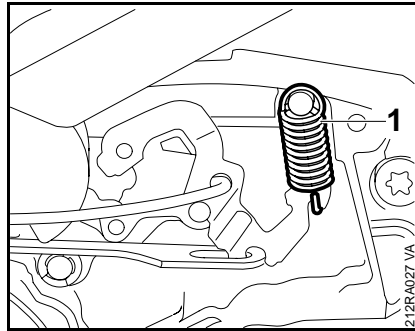

- Attach the spring (1) to the pivot pin.

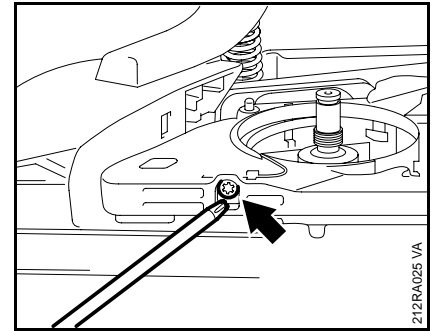

- Fit the screw (arrow) and tighten it down firmly – 3.5

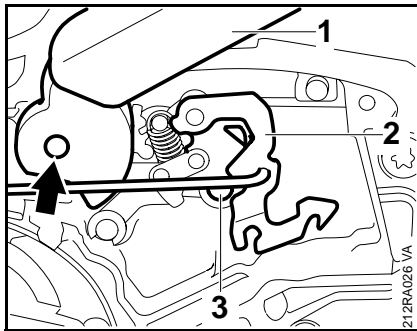

- Position bearing boss of the hand guard (1) against the pivot pin and fit the other side of the hand guard over the fan housing.

- Press the hand guard (1) carefully downward, and push the brake lever (2) onto its pivot pin (3) at the same time.

Coat all sliding and bearing points with STIHL multipurpose grease – 16.

- Lubricate the new brake band with a few drops of chain oil.

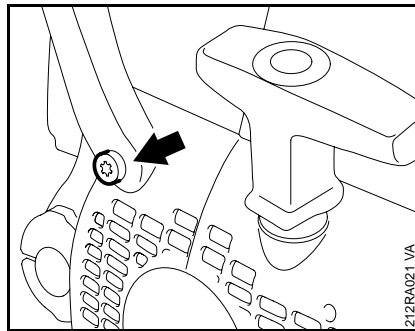

- Fit the screw (arrow) and tighten it down firmly – 3.5

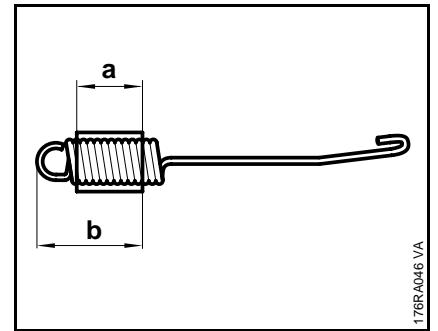

- Turns of brake spring must be tightly against one another in the relaxed condition. If this is not the case, replace the brake spring.

- Check correct position of protective tube:

a = 31 mm  
b = 44 mm

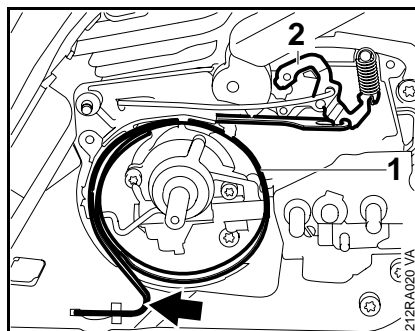

- Attach the brake band (1) to the brake lever (2) and then push it into the slot in the crankcase (arrow).

### 5.5.3 Brake Cable

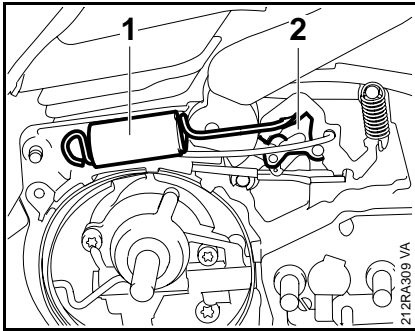

- Hook the brake spring (1) to the brake lever (2).

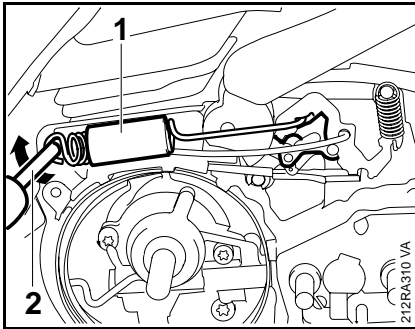

- Use the assembly tool 1117 890 0900 to attach the brake spring (1) to the anchor pin (arrow).

Reassemble all other parts in the reverse sequence.

- Lubricate sliding points with grease – 5.5.6
- Check play – 5.5.4

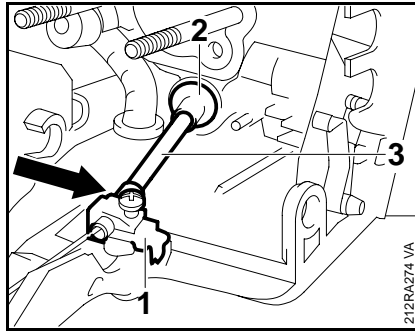

- Separate crankcase and tank housing – 12.9
- Remove the brake cable from the switch lever – 10.2.2
- Push the support (1) sideways and out of its mount.
- Use a suitable tool to pry the grommet (2) out of the tank housing.
- Pull the brake cable (3) out of the tank housing.

Reassemble in the reverse sequence.

- Adjust play – 5.5.4
- Check operation of the coasting brake – 5.5.6

### 5.5.4 Checking Play

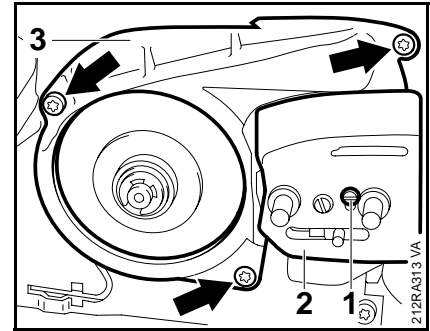

- Remove the cutting attachment – 5.1
- Pull the hand guard toward the front handle.
- Take out the screw (1).
- Remove the side plate (2).
- Take out the screws (arrows).
- Remove the cover (3).

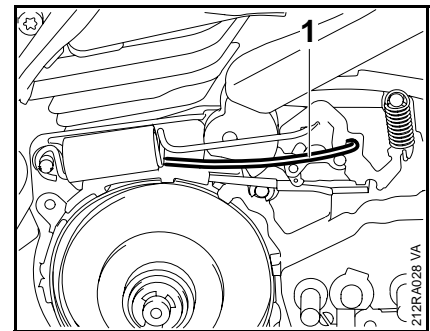

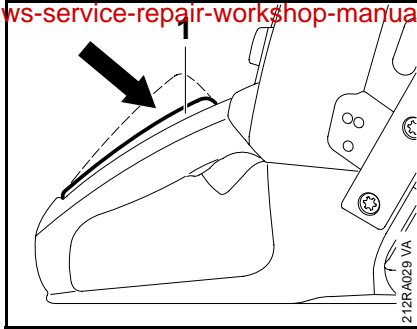

- The brake cable (1) must hang loosely in the crankcase when the brake is disengaged.

### 5.5.5 Adjusting Play

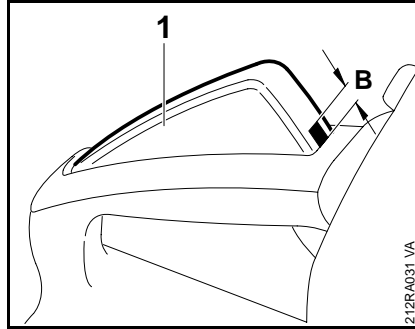

- Press down interlock lever (1) all the way and hold it in that position.



- Let go of the interlock lever (1).
- Check free travel by slowly squeezing the interlock lever (1). Play must be within the mark (B) at the front end of the interlock lever. The brake lever must not move. If it does, adjust play –  5.5.5

Reassemble in the reverse sequence.

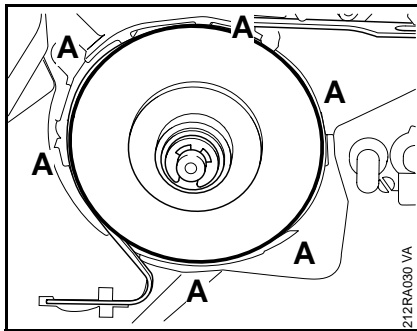

- The brake band (1) must locate without any play against the points (A) in the crankcase.

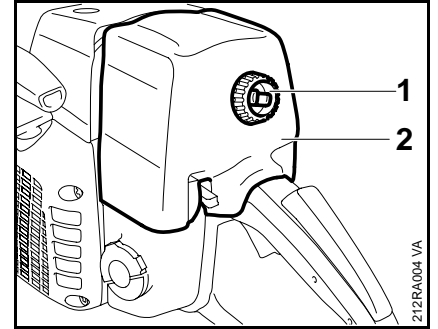

- Release twist lock (1).
- Remove the carburetor box cover (2).

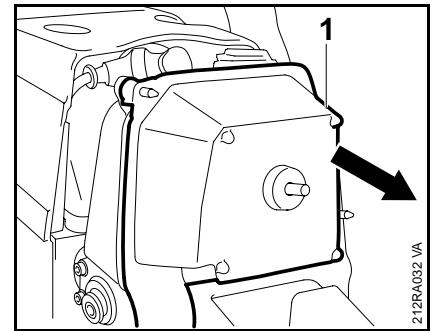

- Lift away the air filter (1) to the rear.