

STIHL MS 290, 310, 390

2004-11

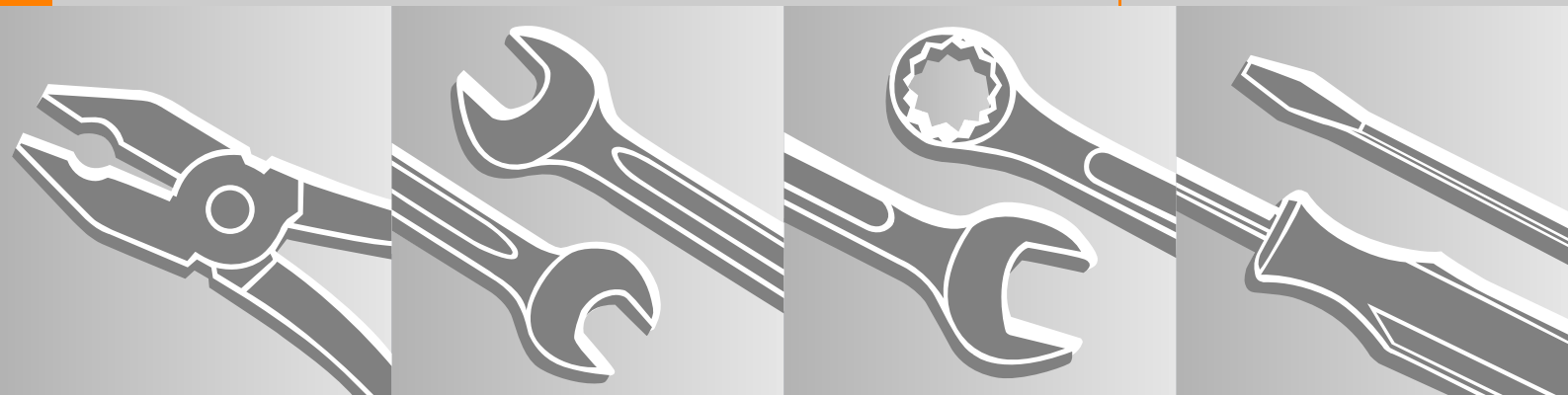

1. Introduction

This service manual contains detailed descriptions of all the typical repair and servicing procedures for this power tool.

As the design concept of models MS 290, MS 310 and MS 390 is almost identical, the descriptions and servicing procedures in this manual generally apply to all three models. Differences are described in detail.

You should make use of the illustrated parts lists while carrying out repair work. They show the installed positions of the individual components and assemblies.

Refer to the latest edition of the relevant parts list to check the part numbers of any replacement parts.

A fault on the machine may have several causes. To help locate the fault, consult the chapter on "Troubleshooting" and the "STIHL Service Training System".

Refer to the "Technical Information" bulletins for engineering changes which have been introduced since publication of this service manual. Technical information bulletins also supplement the parts list until an updated edition is issued.

The special tools mentioned in the descriptions are listed in chapter "Special Servicing Tools" of this manual. Use the part numbers to identify the tools in the "STIHL Special Tools" manual which lists all the special servicing tools currently available from STIHL.

Symbols are included in the text and pictures for greater clarity. The meanings are as follows:

In the descriptions:

- = Action to be taken as shown in the illustration (above the text)
- = Action to be taken that is not shown in the illustration (above the text)

In the illustrations:

- Pointer (short arrow)
- ➡ Direction of movement (long arrow)
- 📖 4.2 = Reference to another chapter, i.e. chapter 4.2 in this example.

Service manuals and technical information bulletins are intended exclusively for the use of properly equipped repair shops. They must not be passed to third parties.

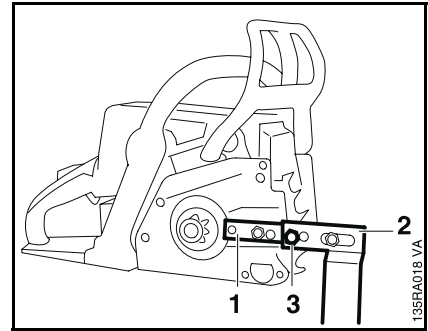

Servicing and repairs are made considerably easier if the clamp (1) 5910 890 2000 is used to mount the machine on assembly stand (2) 5910 890 3100 so that one clamp screw engages the outer 10 mm hole (3) in the assembly stand.

To service the underside of the machine, turn it upside down and mount it so that one clamp screw engages the inner 10 mm hole in the assembly stand.

Note:

Pull the hand guard back against the front handle for this purpose.

Always use original STIHL replacement parts.

They can be identified by the STIHL part number, the **STIHL** logo and the STIHL parts symbol . This symbol may appear alone on small parts.

2. Safety Precautions

If the engine is started up in the course of repairs or maintenance work, observe all local and country-specific safety regulations as well as the safety precautions and warnings in the instruction manual.

Gasoline is an extremely flammable fuel and can be explosive in certain conditions.

Improper handling may result in burns or other serious injuries.

Warning!

Do not bring any fire, flame, spark or other source of heat near the fuel. All work with fuel must be performed outdoors only. Spilled fuel must be wiped away immediately.

3. Specifications

3.1 Engine

	MS 290	MS 310	MS 390
Displacement:	56.5 cm ³	59.0 cm ³	64.1 cm ³
Bore:	46 mm	47 mm	49 mm
Stroke:	34 mm	34 mm	34 mm
Engine power to ISO 7293:	3.0 kW (4.1 bhp) at 9,500 rpm	3.2 kW (4.4 bhp) at 9,500 rpm	3.4 kW (4.6 bhp) at 9,500 rpm
Max. permissible engine speed with bar and chain:	12,500 rpm	13,000 rpm	13,000 rpm
Idle speed:	2,800 rpm		
Clutch:	Centrifugal clutch without linings		
Clutch engages at:	3,500 rpm		
Crankcase leakage test at gauge pressure:	0.5 bar		
under vacuum:	0.5 bar		

3.1.1 Engine (USA only)

	MS 290	MS 310	MS 390
Displacement:	3.44 cu. in	3.6 cu. in	3.91 cu. in
Bore:	1.81 in	1.85 in	1.92 in
Stroke:	1.33 in	1.33 in	1.33 in
Engine power to ISO 7293:	2.8 kW (3.8 bhp) at 9,500 rpm	3.0 kW (4.1 bhp) at 9,500 rpm	3.2 kW (4.4 bhp) at 9,500 rpm
Max. permissible engine speed with bar and chain:	12,500 rpm	13,000 rpm	13,000 rpm
Idle speed:	2,800 rpm		
Clutch:	Centrifugal clutch without linings		
Clutch engages at:	3,500 rpm		
Engine leakage test at gauge pressure:	7.25 psi		
under vacuum:	7.25 psi		

3.2 Fuel System

Carburetor leakage test at gauge pressure:	0.8 bar (11.60 psi)
Operation of tank vent at gauge pressure:	0.3 bar (4.35 psi)
Fuel:	as specified in instruction manual

3.3 Ignition System

Air gap between ignition module and fanwheel:	0.15 – 0.3 mm
Spark plug (suppressed):	Bosch WSR 6F NGK BPMP 7 A
Electrode gap:	0.5 mm

3.4 Chain Lubrication

Fully automatic, speed-controlled oil pump with rotary piston	
Oil delivery rate:	8 – 18 cm ³ at 10,000 rpm

3.5 Tightening Torques

DG screws are used in polymer and light metal components. These screws form a permanent thread when they are installed for the first time. They can be removed and installed as often as necessary without impairing the strength of the screwed assembly, providing the specified tightening torque is observed.

For this reason it is **essential to use a torque wrench**.

Fastener	Thread size	For component	Torque		Remarks
			kpm	Nm	
Screw	DG4x15	Cover, chain tensioner/engine housing	0.25	2.5	
Collar screw	DG8x24	Guide bar	1.6	16.0	
Collar screw	M10x21	Collar screw for guide bar/engine pan	3.0	30.0	1)
Screw	DG4x15	Chain brake cover/engine housing	0.25	2.5	
Screw	DG4x15	Handle housing/handle molding	0.16	1.6	
Screw	DG5x24	Handlebar/handle housing	0.35	3.5	
Screw	DG5x24	Hand guard, left	0.35	3.5	2)
Screw	DG4x15	Shroud/engine housing	0.25	2.5	
Slotted screw	M5	Box filter/carburetor	0.2	2.0	
Screw	DG5x16	Chain catcher/engine housing	0.35	3.5	
Screw	DG5x16	Spiked bumper/engine housing	0.35	3.5	
Screw	DG5x24	Fan housing/engine housing	0.35	3.5	
Screw	DG4x15	Ground connection to cylinder	0.4	4.0	
Carrier	M12x1L	Carrier/crankshaft	5.0	50.0	
Screw	DG6x52	Engine housing/cylinder	1.1	11.0	
Screw	DG5x24	Annular buffer/handlebar	0.35	3.5	
Screw	DG5x24	Annular buffer/engine housing	0.35	3.5	
Locknut	M5	Muffler cover/cylinder/screw	0.8	8.0	
Nut	M8x1	Flywheel/crankshaft	2.8	28.0	
Nut	M5	Carburetor/handle housing/screw	0.33	3.3	
Spark plug	M14x1.25	Spark plug	2.5	25.0	
Screw	DG5x24	Ignition module/engine housing	0.48	4.8	
Screw	DG4x15	Oil pump	0.4	4.0	

Remarks:

1) Loctite 243, medium strength

2) with sleeve

4. Troubleshooting Chart
4.1 Clutch, Chain Drive, Chain Brake, Chain Tensioner

Condition	Cause	Remedy
Saw chain stops under load at full throttle	Clutch shoes badly worn	Install new clutch
	Clutch drum badly worn	Install new clutch drum
	Brake band stuck	Check freedom of movement and function of brake band
Saw chain rotates at idle speed	Engine idle speed too high	Readjust with idle speed screw (LA) (counterclockwise)
	Clutch springs stretched or fatigued	Replace the clutch springs, or clutch if necessary
	Clutch spring hooks broken	Replace the clutch springs
Loud noises	Clutch springs stretched or fatigued	Replace all clutch springs
	Needle cage damaged	Fit new needle cage
	Clutch shoe retainer broken	Fit new retainer
	Clutch shoes and carrier worn	Install new clutch
Chain sprocket wears rapidly	Chain not properly tensioned	Tension chain as specified
	Wrong chain pitch	Fit chain of correct pitch
	Insufficient chain lubrication	Check chain lubrication
	Chain sprocket worn	Install new chain sprocket
Chain does not stop immediately when brake is activated	Brake spring stretched or broken	Fit new brake spring
	Brake band stretched / worn / broken	Fit new brake band
	Clutch drum worn	Install new clutch drum

4.2 Rewind Starter

Condition	Cause	Remedy
Starter rope broken	Rope pulled out too vigorously as far as stop or over edge, i.e. not vertically	Fit new starter rope
	Normal wear	Fit new starter rope
Starter rope does not rewind	Rewind spring broken	Fit new rewind spring
	Spring overtensioned – no reserve when rope is fully extended	Fit new rewind spring
	Very dirty or corroded	Clean or replace rewind spring
Starter rope can be pulled out almost without resistance (crankshaft does not turn)	Guide peg on pawls or pawls themselves are worn	Fit new pawls
	Spring clip fatigued	Fit new spring clip
Starter rope is difficult to pull and rewinds very slowly	Starter mechanism is very dirty	Clean complete starter mechanism
	Lubricating oil on rewind spring becomes viscous at very low outside temperatures (spring windings stick together)	Coat rewind spring with a standard solvent-based degreasant (containing no chlorinated or halogenated hydrocarbons). Then pull rope carefully several times until normal action is restored

4.3 Chain Lubrication

In the event of trouble with the chain lubrication system, check and rectify other sources of faults before disassembling the oil pump.

Condition	Cause	Remedy
Chain receives no oil	Oil tank empty	Fill up with oil
	Oil inlet hole in guide bar is blocked	Clean oil inlet hole
	Intake hose or pickup body (strainer) clogged or intake hose ruptured	Replace suction hose and pickup body
	Sealing ring between oil pump and elbow connector or between elbow connector and engine housing faulty	Remove oil pump, fit new sealing ring and refit oil pump
	Valve in oil tank blocked	Clean/replace valve
	Teeth on pump piston and/or worm worn	Fit new oil pump
Machine losing chain oil	Sealing ring between oil pump and elbow connector or between elbow connector and engine housing faulty	Remove oil pump, fit new sealing ring and refit oil pump
	Oil pump damaged or worn	Fit new oil pump
Oil pump delivers insufficient oil	Control screw and/or control edge on pump piston worn	Replace control screw and/or oil pump
	Oil pump worn	Fit new oil pump

4.4 Ignition System

Warning!

Exercise extreme caution while carrying out maintenance and repair work on the ignition system. The high voltages which occur can cause serious or fatal accidents!

Condition	Cause	Remedy
Engine runs roughly, misfires, temporary loss of power	Spark plug boot is loose	Press boot firmly onto spark plug and fit new spring if necessary
	Spark plug sooted, smeared with oil	Clean the spark plug or replace if necessary
	Incorrect air gap between ignition coil and flywheel	Set air gap correctly
	Flywheel cracked or has other damage or pole shoes have turned blue	Install new flywheel
	Ignition timing wrong, flywheel out of adjustment, key in flywheel has sheared off	Install new flywheel
	Weak magnetization in flywheel – pole shoes have turned blue	Install new flywheel
	No ignition spark	Check operation of Master Control lever and ignition module
No ignition spark		Faulty insulation on ignition lead or short circuit wire. Use ohmmeter to check ignition lead for break. If break is detected or high resistance measured, fit a new ignition lead
	Check operation of spark plug. Inspect Master Control lever, ignition coil/lead for damage insulation and leakage current.	Clean or replace spark plug, replace faulty parts of ignition system
	Engine pan damaged (cracks)	Replace engine pan

4.5 Carburetor

Condition	Cause	Remedy
Carburetor floods; engine stalls	Inlet needle not sealing. Foreign matter in valve seat or cone damaged	Remove and clean or replace the inlet needle, clean the fuel tank, pickup body and fuel line if necessary
	Inlet control lever sticking on spindle	Free off inlet control lever
	Helical spring not located on nipple of inlet control lever	Remove the inlet control lever and refit it correctly
	Perforated disc on diaphragm is deformed and presses constantly against the inlet control lever	Fit a new metering diaphragm
	Inlet control lever too high (relative to correct installed position)	Set inlet control lever flush with top edge of housing
Poor acceleration	Idle jet too lean	Rotate low speed screw (L) counterclockwise (richer), no further than stop
	Main jet too lean	Rotate high speed screw (H) counterclockwise (richer), no further than stop
	Inlet control lever too low (relative to correct installed position)	Set inlet control lever flush with top edge of housing
	Inlet needle sticking to valve seat	Remove inlet needle, clean and refit
	Diaphragm gasket leaking	Fit new diaphragm gasket
	Metering diaphragm damaged or shrunk	Fit new metering diaphragm
	Impulse hose damaged or kinked	Fit new impulse hose

Condition	Cause	Remedy
Engine will not idle, idle speed too high	Throttle shutter opened too wide by idle speed screw (LA)	Reset idle speed screw (LA) correctly
	Engine leaking	Seal the engine
Engine stalls at idle speed	Idle jet bores or ports blocked	Clean jet bores and ports and blow clear with compressed air
	Idle jet too rich or too lean	Set low speed screw (L) correctly
	Setting of idle speed (LA) incorrect – throttle shutter completely closed	Set idle speed screw (LA) correctly
	Small plastic plate in valve jet does not close	Clean or renew valve jet
Engine speed drops quickly under load – low power	Air filter dirty	Clean the air filter
	Throttle shutter not opened fully	Check linkage
	Tank vent faulty	Clean tank vent or replace if necessary
	Fuel pickup body dirty	Clean the pickup body, fit a new filter
	Fuel strainers dirty	Replace the fuel strainers
	Leak in fuel line between tank and fuel pump	Seal connections or install a new fuel line
	Setting of high speed screw (H) too rich	Rotate high speed screw (H) clockwise (leaner), no further than stop
	Main jet bores or ports blocked	Clean the carburetor
Pump diaphragm damaged or fatigued	Fit new pump diaphragm	

4.6 Engine

Always check and, if necessary, repair the following parts before looking for faults on the engine:

- Air filter
- Fuel system
- Carburetor
- Ignition system

Condition	Cause	Remedy
Engine does not start easily, stalls at idle speed, but operates normally at full throttle	Manifold leaking	Seal or replace the manifold
	Oil seals on crankshaft damaged	Replace the oil seals
	Joint between cylinder and engine pan leaking or damaged (cracks)	Seal or replace engine pan
Engine does not deliver full power or runs erratically	Piston rings worn or broken	Fit new piston rings
	Muffler / spark arresting screen (if fitted) carbonized	Clean the muffler (inlet and exhaust), replace spark arresting screen, replace muffler if necessary
	Air filter element dirty	Replace air filter element
	Fuel / impulse line severely kinked or damaged	Replace lines or position them free from kinks
Engine overheating	Insufficient cylinder cooling. Air inlets in fan housing blocked or cooling fins on cylinder very dirty	Thoroughly clean all cooling air openings and the cylinder fins

5. Clutch, Chain Drive, Chain Brake and Chain Tensioner

5.1 Clutch Drum/Chain Sprocket

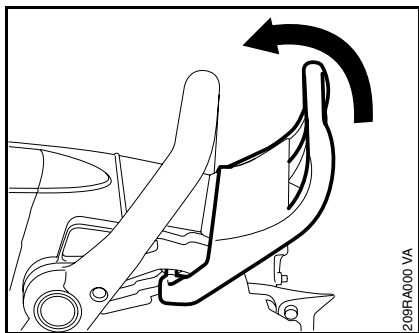

– Remove the chain sprocket cover.

- Disengage the chain brake by pulling the hand guard towards the front handle.

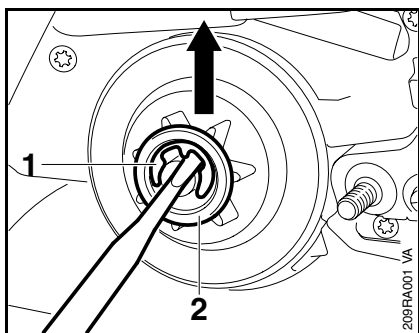

- Remove the E-clip (1).
- Remove the washer (2).

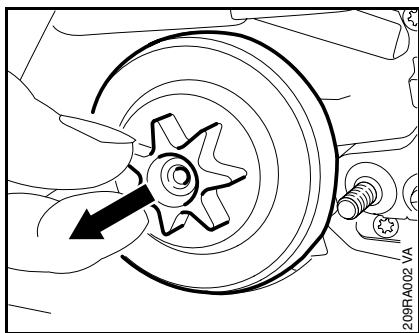

- If a rim sprocket is fitted, pull it off.
- Remove the clutch drum/chain sprocket.

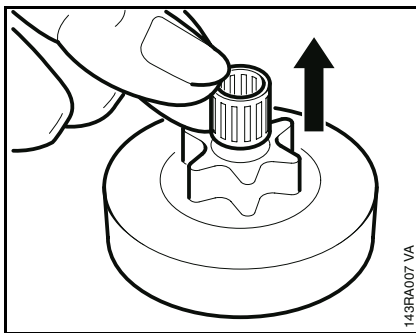

- Remove the needle cage.
- Clean the clutch drum/chain sprocket with standard solvent-based degreasant containing no chlorinated or halogenated hydrocarbons, 13.

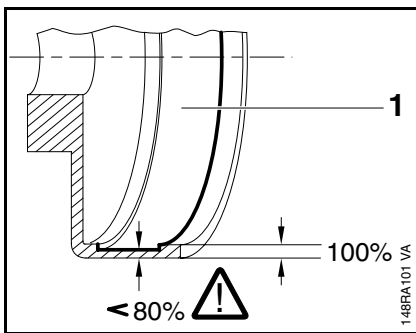

- Inspect the clutch drum (1) for signs of wear.

If there are signs of serious wear on the inside diameter of the clutch drum (1), check the remaining wall thickness. If it is less than about 80% of the original thickness, fit a new clutch drum.

If the clutch drum has to be replaced, also check the brake band, 5.6.2

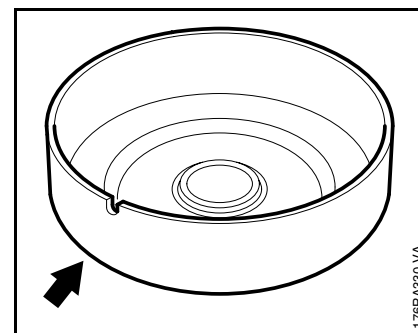

- If the clutch drum/chain sprocket is still serviceable, use No. 120 emery paper or emery cloth (grain size approx. 120 μm) to clean and roughen its friction surface.

Install in the reverse sequence.

- Clean crankshaft stub with standard solvent-based degreasant containing no chlorinated or halogenated hydrocarbons. Wash needle cage and lubricate with grease, 13.
- Replace damaged needle cage.

5.2 Chain Catcher

- Rotate clutch drum/chain sprocket and apply slight pressure at the same time until the oil pump drive spring engages the notch.
- Fit rim sprocket with the cavities facing outwards.

Install all other parts in the reverse sequence.

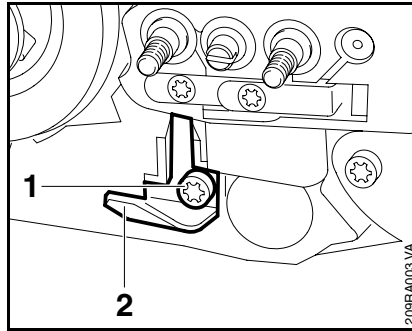

- Remove the chain sprocket cover, bar and chain.
- Take out the screw (1).
- Remove the chain catcher (2).

Install in the reverse sequence.

Check correct installed position.

5.3 Spiked Bumper

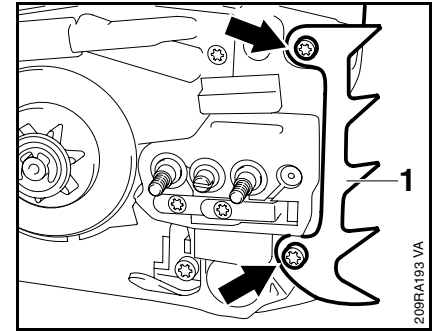

- Remove the chain sprocket cover, bar and chain.
- Take out the screws (arrows).
- Remove the spiked bumper (1).

Install in the reverse sequence.

5.4 Collar Stud

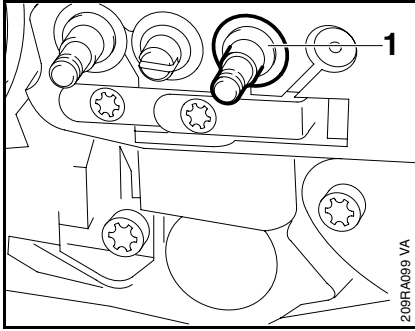

– Remove the chain sprocket cover with cutting attachment.

- Use M 8 stud puller 5910 893 0501,  12, to remove the collar stud (1).

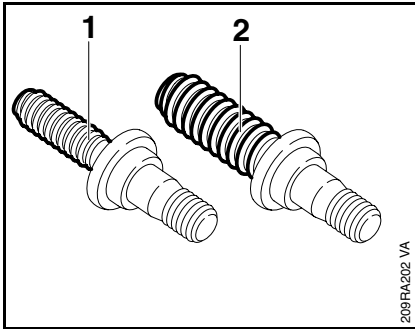



If the thread in the engine housing is badly damaged or stripped, it will not be possible to secure the standard collar stud (1) properly. This situation can be remedied by using the DG 9 collar stud 1127 664 2410 (2).

Do not drill out the mounting bore in the engine housing.

- Coat thread of the DG 9 collar stud with Loctite 648,  13.
- Install the collar stud squarely.

5.5 Clutch

- Troubleshooting –  4.1
- Remove the clutch drum/chain sprocket,  5.1
- Remove the prefilter,  11.1

Install all other parts in the reverse sequence.

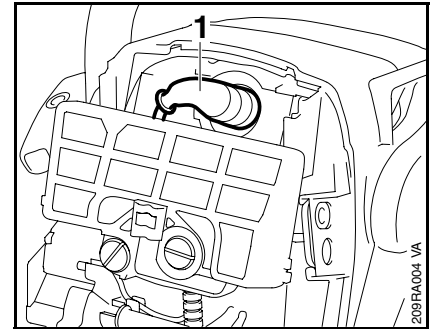

- remove the spark plug boot (1).
- Unscrew the spark plug.

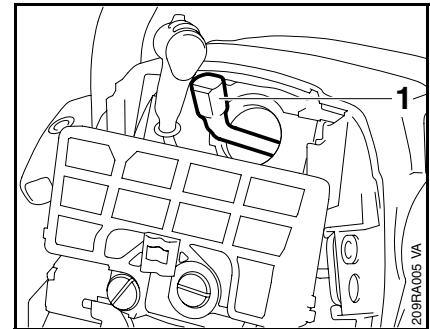

- Push the locking strip (1) 0000 893 5903 into the spark plug hole so that "TOP" faces up.

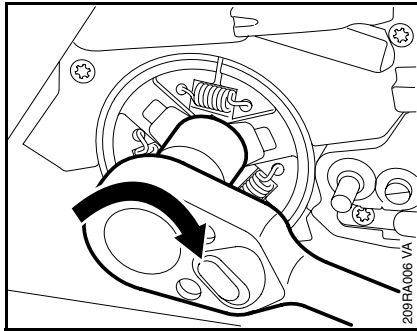

- Unscrew the clutch from the crankshaft in the direction of the arrow (left-hand thread).

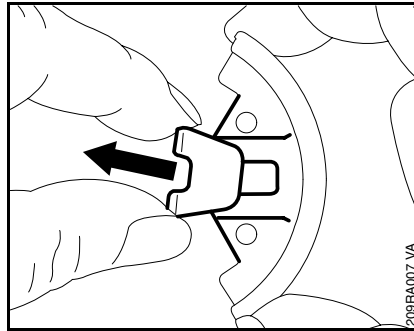

- Pull the retainers off the clutch shoes.

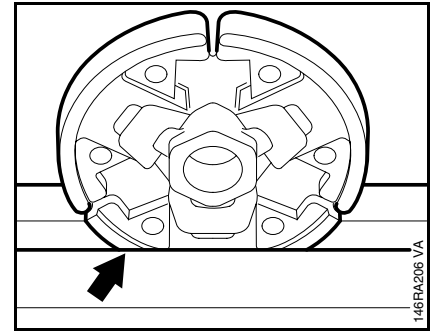

- Carefully clamp the clutch in a vise.

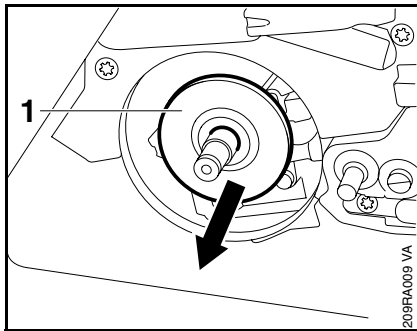

- Take the cover washer (1) (where fitted) off the crankshaft.

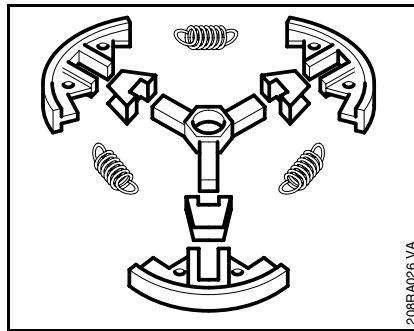

- Clean all parts in a little standard solvent-based degreasant containing no chlorinated or halogenated hydrocarbons, 13.
- Replace any damaged parts.

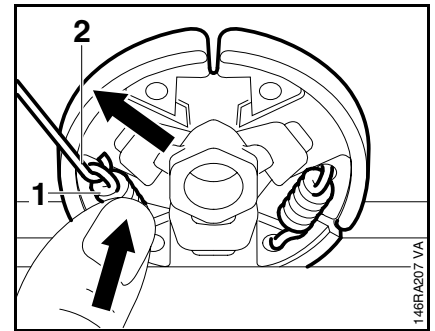

- Attach one end of each spring (1) to the clutch shoes.
- Use the hook (2) 5910 890 2800 to attach other ends of springs and press them firmly into the clutch shoes.

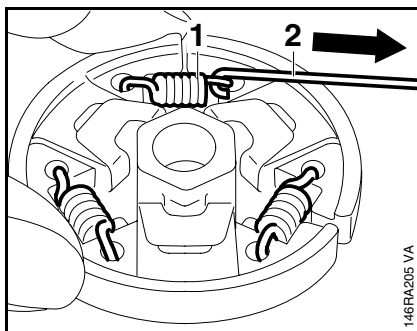

- Use hook (2) 5910 890 2800 to remove the clutch springs (1).
- Pull the clutch shoes off the carrier.

Install in the reverse sequence.

Important:

Clutches marked **1125/01** on the carrier must be installed **without** cover washer.

Clutches marked **1127/00** on the carrier must be installed **with** cover washer.

5.6 Chain Brake

5.6.1 Checking Operation

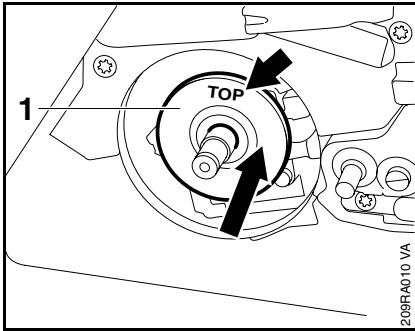

- Push cover washer (1), "TOP" (arrow) facing outward, onto the crankshaft.

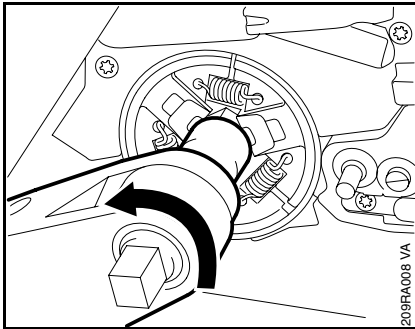

- Screw on the clutch and tighten it down firmly, [5.3.5](#)

Install all other parts in the reverse sequence.

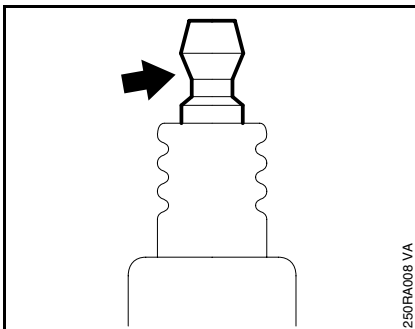

- If terminal of spark plug has a detachable adapter nut, make sure it is tightened down firmly.

The chain brake is one of the most important safety devices on the chainsaw. Its efficiency is measured in terms of the chain braking time, i.e. the time that elapses between activating the brake and the saw chain coming to a complete standstill. The shorter the braking time, the better the efficiency and protection offered against being injured by the rotating chain.

Contamination (with chain oil, chips, fine particles of abrasion, etc.) and smoothing of the friction surfaces of the brake band and clutch drum impair the coefficient of friction. This, in turn, reduces the frictional forces and thus prolongs the braking time. A fatigued or stretched brake spring has the same negative effect.

- Start the engine.
- With the chain brake activated (locked), open the throttle wide for a brief period (max. 3 seconds) – the chain must not rotate.
- With the chain brake released, open the throttle wide and activate the brake manually – the chain must come to an abrupt stop.

The braking time is in order if deceleration of the saw chain is imperceptible to the eye.

5.6.2 Removing and Installing

- Remove the clutch drum/chain sprocket, [5.1](#)
- Relieve tension of brake spring by pushing hand guard forward.

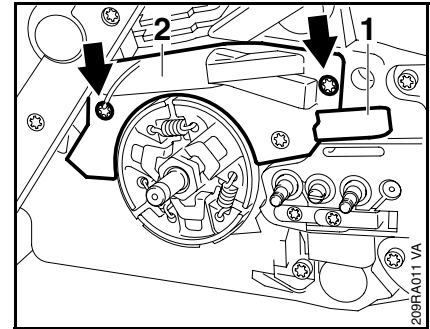

- Remove the bumper strip (1).
- Take out the screws (arrows).
- Remove the cover (2).

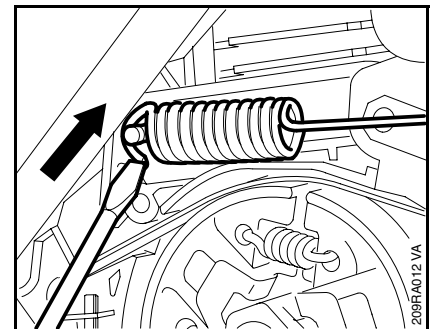

- Carefully ease the brake spring off the anchor pin.
- If the groove in the anchor pin is worn, install a new pin, [5.7.1](#)

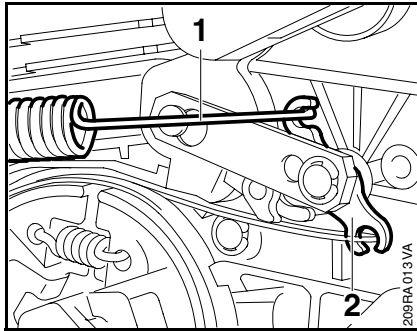

- Remove the brake spring (1) from the bell crank (2).

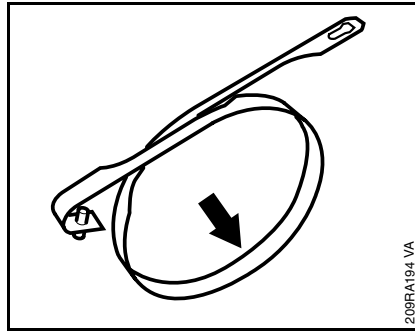

- Install a new brake band if there are noticeable signs of wear (large areas on inside diameter and/or parts of outside diameter) and its remaining thickness is less than 0.6 mm.

Thickness of brake band must not be less at any point.

- If the brake band is still serviceable, use No. 120 emery paper or emery cloth (grain size approx. 120 µm) to clean and roughen its friction surface (inside diameter).

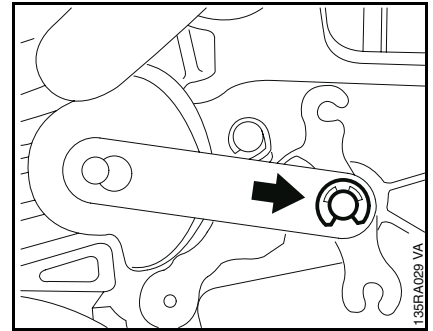

- Remove the E-clip (arrow).

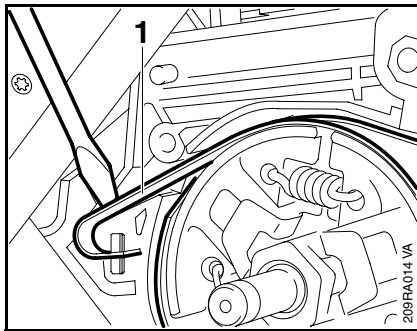

- Pry the brake band (1) out of the engine housing.

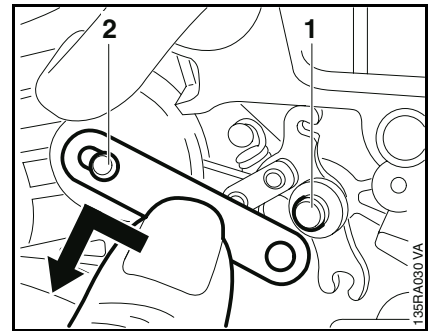

- Remove the strap from the bell crank pivot pin (1).
- Slide the strap up and take it off the hand guard pivot pin (2).

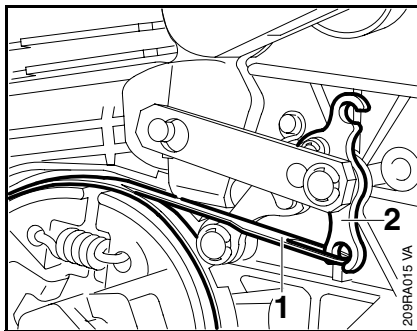

- Disconnect the brake band (1) from the bell crank (2).

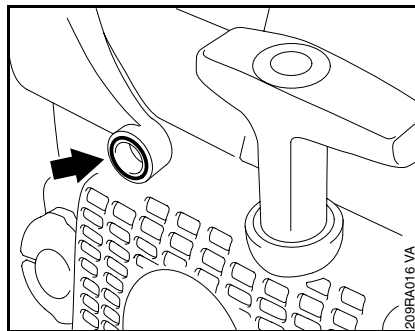

- Take the screw (1) together with the bushing (2) out of the hand guard.

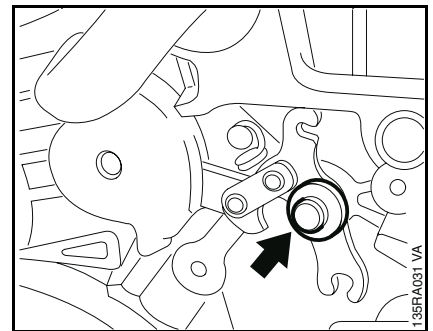

- Remove the washer (arrow).

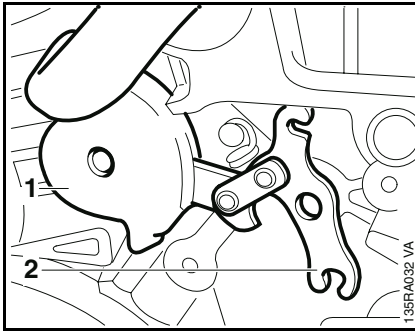

- Carefully pry the hand guard (1) and bell crank (2) off their pivot pins and remove them together.
- Pull the bell crank out of the hand guard.

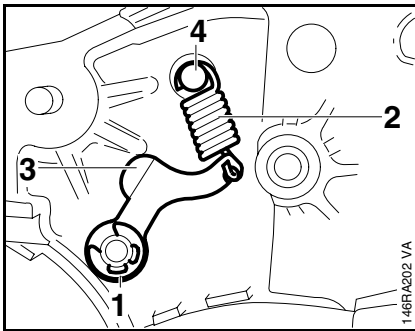

- Detach the spring (2).
- Remove the E-clip (1).
- Pull off the cam lever (3).
- Inspect parts and replace if damaged.
- Clean the entire housing recess for the chain brake.
- If the groove in the pin (4) (for spring) is worn, install a new pin, 5.7.1
- If necessary, pull the bell crank out of the hand guard.

Install in the reverse sequence.

- Lubricate all sliding and bearing points with STIHL multipurpose grease or, preferably, molybdenum grease (e.g. Molykote), 13.

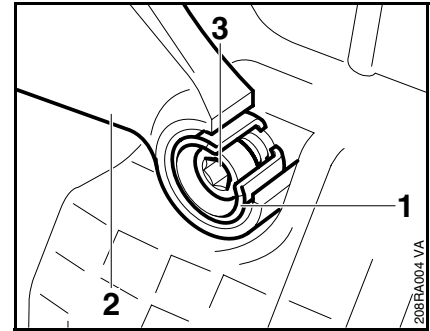

- Fit the bushing (1) in the hand guard (2).
- Insert M5x24 screw (3) and tighten it down firmly, 3.5

Install all other parts in the reverse sequence.

- Check operation of chain brake, 5.6.1

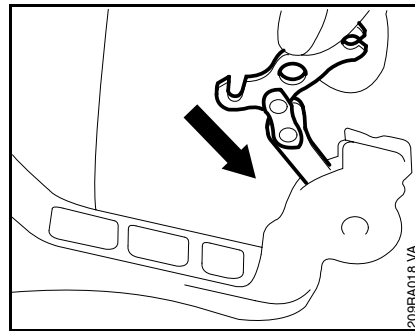

- Push the bell crank into the side of the hand guard. The short arm of the bell crank must point to the top of the hand guard.

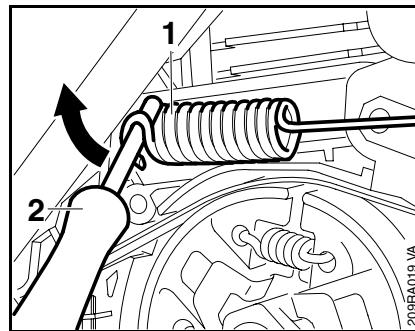

- Use assembly tool (2) 1117 890 0900 to attach the brake spring (1) to the anchor pin.

5.7 Replacing Pins

5.7.1 Removing

If the groove of the anchor pin is worn, install a new pin.

Drive out the pin in the direction of the arrow so as not to damage the annular bead which was formed in the engine housing bore when the pin was originally installed. The new anchor pin will not otherwise fit properly and the brake spring will not be held securely.

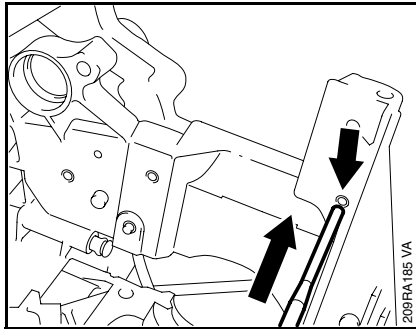

Hand guard pivot pin

- Disconnect the brake spring, 5.6.2
- Remove the cylinder, 6.5.1
- Use a 4 mm drift to remove the pin by driving it outwards.

If the pin cannot be seen on the inside of the housing, use a suitable tool to expose it.

- Installing, 5.7.2

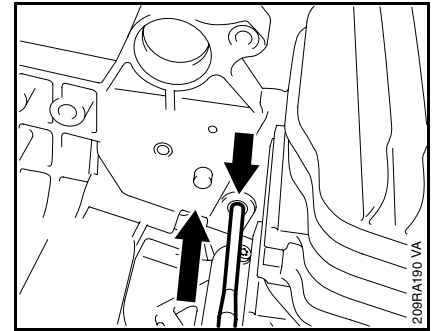
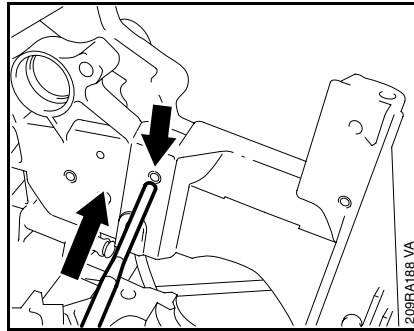

Cam lever pivot pin

- Remove the hand guard, 5.6.2
- Remove the cylinder, 6.5.1
- Use a 4 mm drift to remove the pin by driving it outwards.
- Installing, 5.7.2

Cam lever pivot pin

- Remove the muffler, 6.1
- Remove the handle housing, 9.2
- Use a 4 mm drift to remove the pin by driving it outwards.
- Installing, 5.7.2

Spring anchor pin

- Remove the muffler, 6.1
- Remove the handle housing, 9.2

Lever pivot pin

- Remove the muffler, 6.1
- Remove the handle housing, 9.2

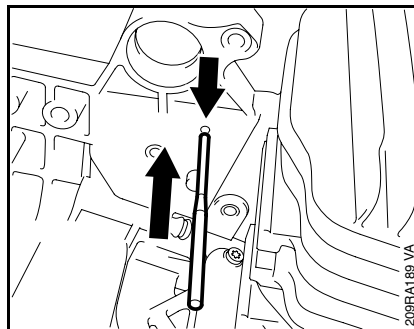

- Use a 2 mm drift to remove the pin by driving it outwards.
- Installing, 5.7.2

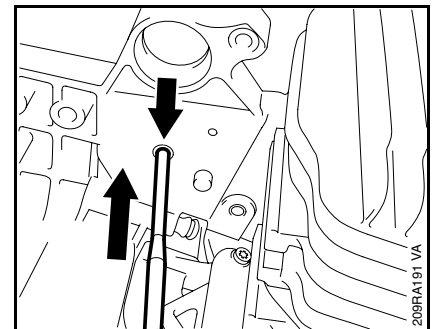

- Use a 4 mm drift to remove the pin by driving it outwards.
- Installing, 5.7.2

5.7.2 Installing

- Before installation, coat the knurled area of the new pin with Loctite 243,  13.
- Position the new pin in the bore so that the knurling on the pin meshes with the existing knurling in the bore. Turn pin back and forth as necessary.
- Carefully tap home the pin squarely from the outside inwards, in direction of cylinder.

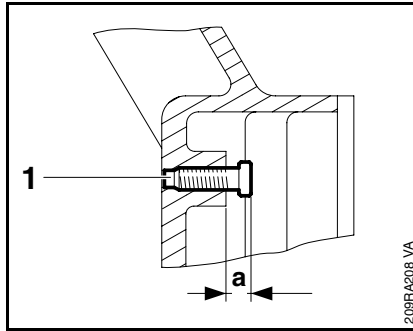

Spring anchor pin

- Drive home pin (1) until dimension "a" is 3.0 ± 0.2 mm

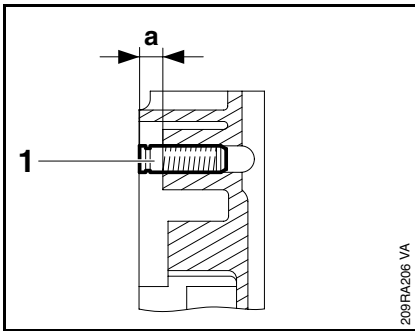

Brake spring anchor pin

- Drive home pin (1) until dimension "a" is 4.5 ± 0.2 mm

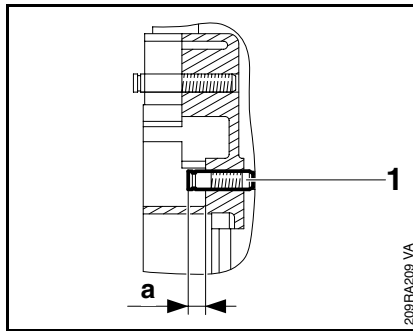

Cam lever pivot pin

- Drive home pin (1) until dimension "a" is 4.6 ± 0.2 mm

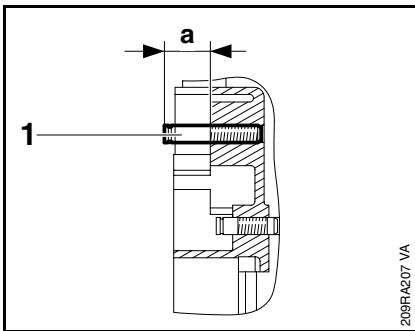

Hand guard pivot pin

- Drive home pin (1) until dimension "a" is 12 ± 0.2 mm

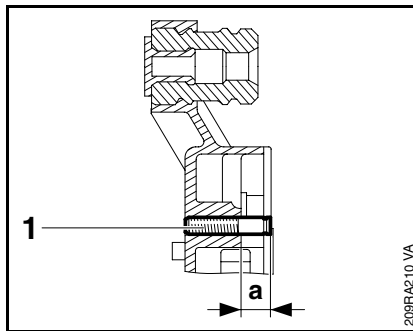

Lever pivot pin

- Drive home pin (1) until dimension "a" is 9.1 ± 0.2 mm

Install all other parts in the reverse sequence.

5.8 Chain Tensioner

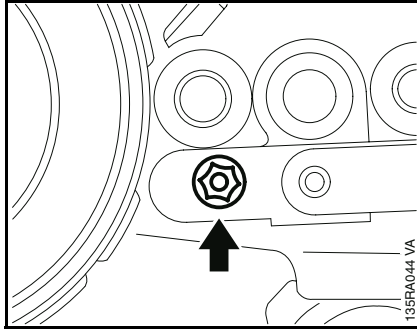

- Remove the chain sprocket cover.
- Take out the screw (arrow).
- Pull tensioner assembly out of the engine housing.

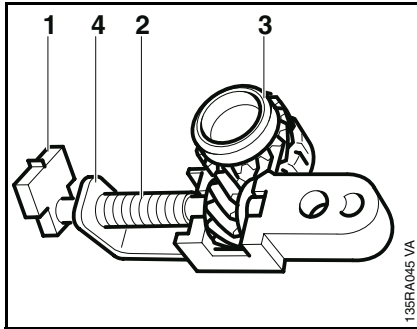

- Take the thrust pad (1) off the adjusting screw (2).
- Rotate the spur gear (3) until the adjusting screw comes out of the tensioner slide (4).

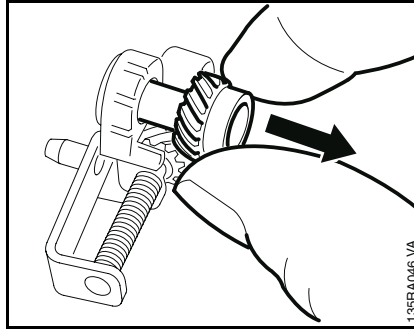

- Pull the spur gear out of the cover.

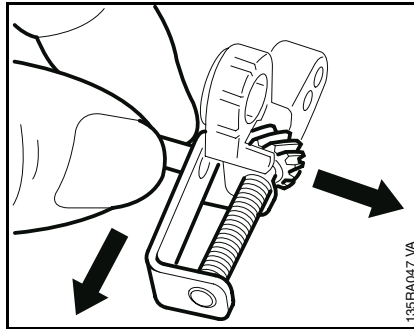

- Pull the tensioner slide off the cover.
- Take the adjusting screw out of the cover.
- Inspect the teeth on the spur gear and adjusting screw. Replace both parts if necessary.

Install in the reverse sequence.

- Coat teeth of adjusting screw and spur gear with grease, 13, before refitting.

6. Engine

6.1 Muffler/Spark Arresting Screen

This machine does not have a conventional crankcase. The engine consists of the cylinder, piston, crankshaft and engine pan.

- Troubleshooting, 4.6

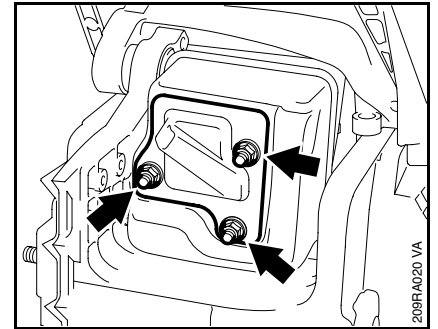

- Unscrew the nuts (arrows).

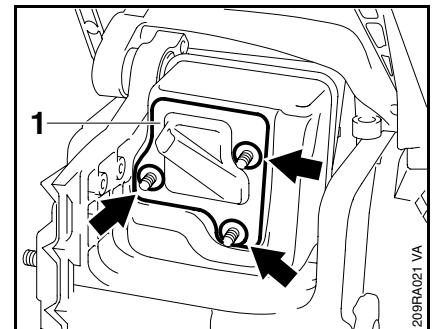

- Remove the conical spring washers (arrows).
- Remove the cover (1).

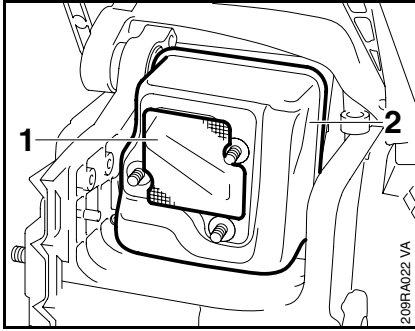

- Remove spark arresting screen (1), if fitted. Clean the screen or fit a new one if necessary
- Remove the muffler (2).

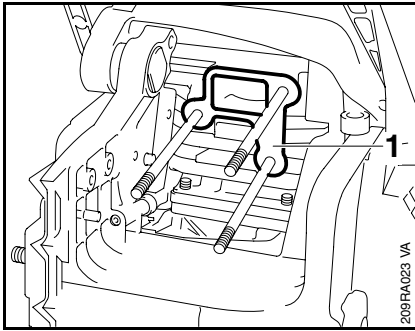

- Remove the gasket (1).

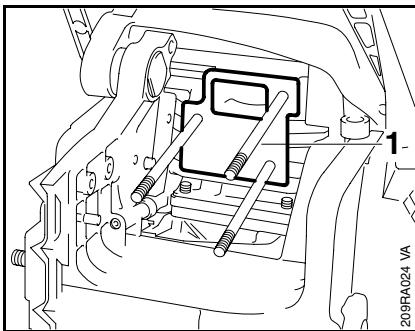

MS 390 (US version only)

- Remove the exhaust gasket (1).

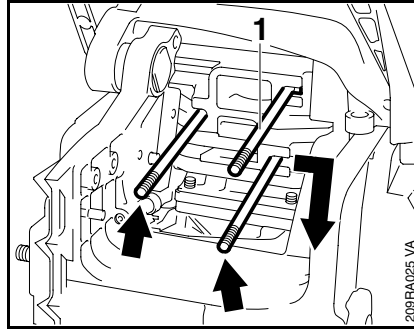

- Remove the screws (arrows) sideways from the flange.

Remove screw (1) as follows:

- Remove the shroud, 6.4
- Remove the screw sideways from the flange.

Install in the reverse sequence.

Install new gaskets.

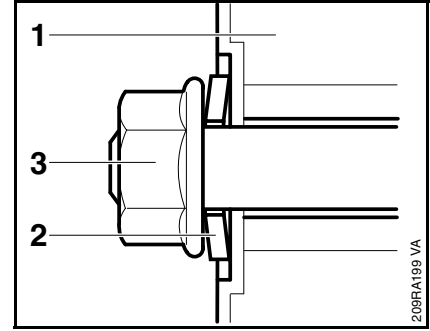

- Install the muffler (1), making sure the conical spring washers (2) are fitted correctly as shown.
- Use new nuts (3) and tighten them down firmly, 3.5.

6.2 Leakage Test

Defective oil seals and gaskets or cracks in castings are the usual causes of leaks. Such faults allow supplementary air to enter the engine and upset the fuel-air mixture.

This makes adjustment of the prescribed idle speed difficult, if not impossible.

Moreover, the transition from idle speed to part or full throttle is not smooth.

The engine housing can be checked thoroughly for leaks with the carburetor and crankcase tester and the vacuum pump,  11.2.2

6.2.1 Preparations

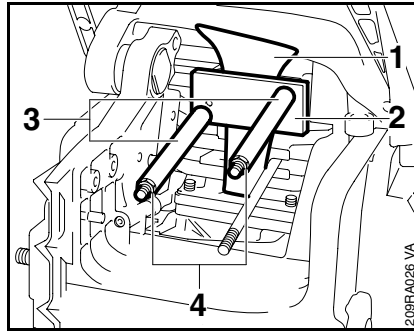

– Remove the muffler,  6.1

- Fit the sealing plate (1) 0000 855 8106 between the mounting screws.

The sealing plate must completely fill the space between the two mounting screws.

- Slip the flange (2) 1123 855 4200 over the screws.
- Fit the sleeves (3) 1123 851 8300 on the screws.
- Fit the nuts (4) and tighten down securely,  3.5

– Remove the carburetor,  11.2.1

– Set the piston to top dead center (T.D.C.). This can be checked through the inlet port.

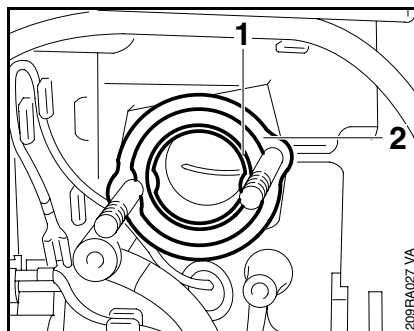

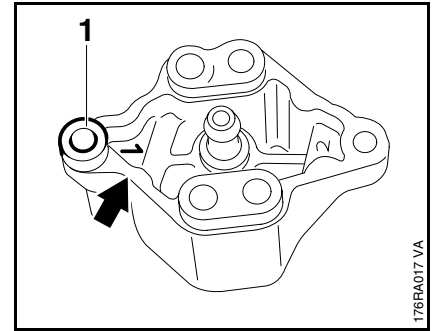

- Check that the sleeve (1) and washer (2) are properly seated.

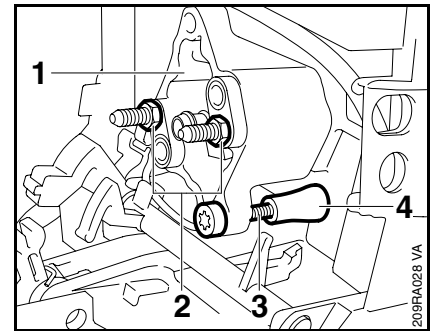

- Check that the pin (1) in test flange 1128 850 4200 is in hole No. 1 (arrow), or fit if necessary.



- Fit the test flange (1).
- Tighten down the screws (2) firmly,  3.5
- Check that spark plug is properly tightened down.
- Pressure test,  6.2.2
- Vacuum test,  6.2.3

When fitting the test flange, make sure the pin (3) locates properly in the impulse hose (4).

6.2.2 Pressure Test

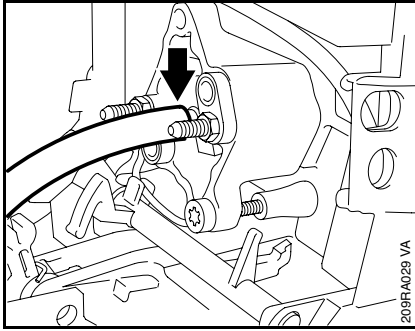

- Carry out preparations, 6.2.1
- Connect pressure hose to nipple (arrow) on test flange.

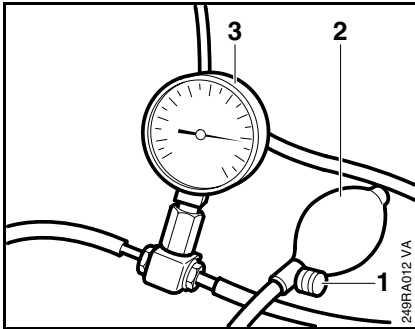

- Close vent screw (1) on the rubber bulb.
- Pump air into the crankcase with rubber bulb (2) until the gauge (3) indicates a pressure of 0.5 bar.

If this pressure remains constant for at least 20 seconds, the crankcase is airtight.

If the pressure drops, the leak must be found and the faulty part replaced.

To find the leak, coat the suspect area with oil and pressurize the crankcase again. Bubbles will appear if a leak exists.

- Repeat the pressure test if necessary.
- After finishing the test, open the vent screw and disconnect the hose.

- Continue with vacuum test, 6.2.3

6.2.3 Vacuum Test

Oil seals tend to fail when subjected to a vacuum, i.e. the sealing lip lifts away from the crankshaft during the piston's induction stroke because there is no internal counterpressure.

A test can be carried out with the vacuum pump to detect this kind of fault.

- Carry out pressure test, 6.2.2

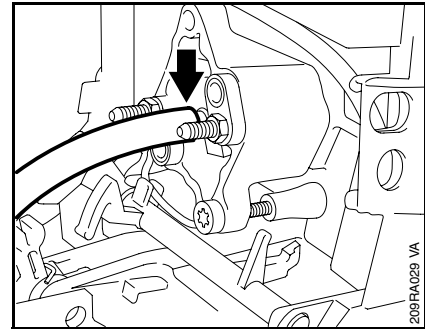

- Connect suction hose of vacuum pump 0000 850 3501 to nipple (arrow) of the test flange.

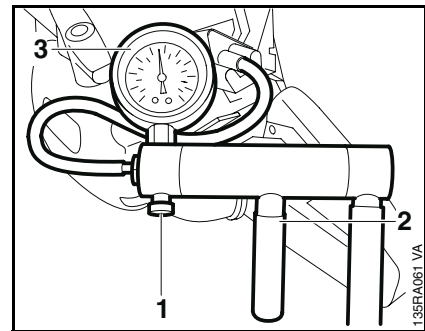

- Close the vent screw (1) on the pump.
- Operate lever (2) until pressure gauge (3) indicates a vacuum of 0.5 bar.

6.3 Oil Seals

If the vacuum reading remains constant, or rises to no more than 0.3 bar within 20 seconds, it can be assumed that the oil seals are in good condition.

However, if the pressure continues to rise (reduced vacuum in the crankcase), the oil seals must be replaced.

– After finishing the test, open the vent screw and disconnect the hose.

– Remove the test flange.

Install in the reverse sequence.

It is not necessary to disassemble the complete engine if only the oil seals have to be replaced.

Clutch side

– Remove the clutch,  5.5

– Remove the oil pump,  10.4.1

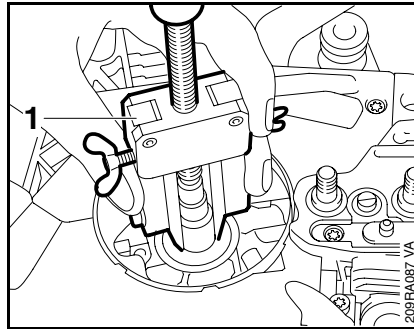

● Apply puller (1) 5910 890 4400 with No. 3.1 jaws 0000 893 3706.

– Clamp the puller arms.

– Pull out the oil seal.

Take care not to damage the crankshaft stub.

– Clean sealing face with standard solvent-based degreasant containing no chlorinated or halogenated hydrocarbons,  13.

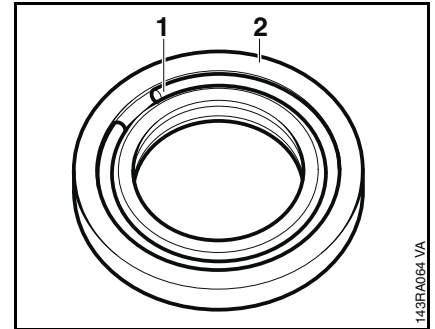

If the engine has **not** been disassembled, only the so-called “**soft**” oil seal 9639 010 1743 may be installed.

● Place the oil seal (2) in position with the clamping ring (1) facing up.

– Lubricate sealing lip of oil seal with grease,  13.

– Apply thin coating of sealant to the outside diameter of the oil seal,  13.

If the engine has been disassembled and the engine pan removed, it is recommended that the “**hard**” oil seal 9639 003 1743 be installed in place of the soft oil seal 9639 010 1743 **before** the engine pan is refitted.

Important:

Do not use a press to install the hard oil seal 9639 003 1743. Install **hard** oil seals as described in  6.7

Install in the reverse sequence.

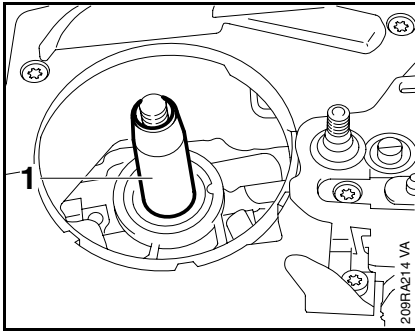

- Push the installing sleeve (1) 1122 893 4600 on to the crankshaft stub.

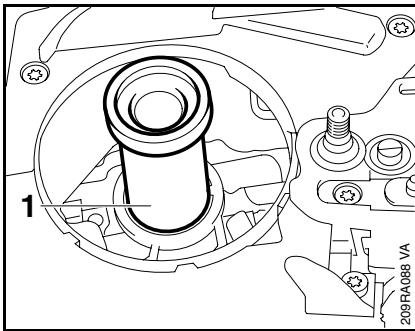

- Use press sleeve (1) 1127 893 2400 to install the "soft" oil seal.
- Wait about one minute, then rotate the crankshaft.
- Install the oil pump, 10.4.1

Install all other parts in the reverse sequence.

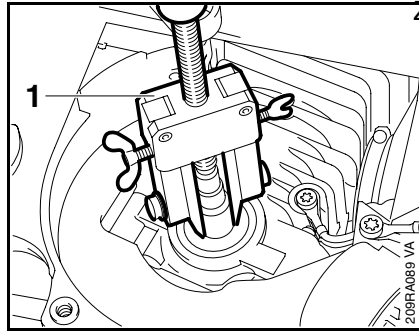

Ignition side

- Remove the flywheel, 7.3
- Apply puller (1) 5910 890 4400 with No. 3.1 jaws 0000 893 3706.
- Clamp the puller arms.
- Pull out the oil seal.

Take care not to damage the crankshaft stub.

- Clean sealing face with standard solvent-based degreasant containing no chlorinated or halogenated hydrocarbons, 13.

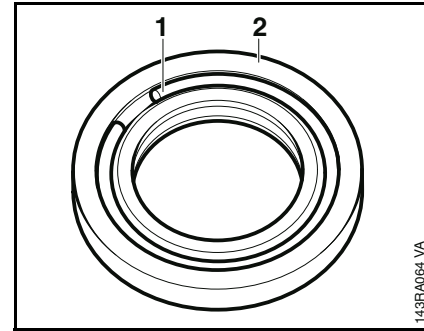

If the engine has **not** been disassembled, only the so-called "soft" oil seal 9639 010 1743 may be installed.

- Place the oil seal (2) in position with the clamping ring (1) facing up.
- Lubricate sealing lip of oil seal with grease, 13.
- Apply thin coating of sealant to the outside diameter of the oil seal, 13.

If the engine has been disassembled and the engine pan removed, it is recommended that the "hard" oil seal 9639 003 1743 be installed in place of the soft oil seal 9639 010 1743 **before** the engine pan is refitted.

Important:

Do not use a press to install the hard oil seal 9639 003 1743. Install **hard** oil seals as described in 6.7

Install in the reverse sequence.

6.4 Shroud

Product: STIHL MS 290,310,390 Chain Saws Service Repair Workshop Manual
Full Download: <https://www.arepairmanual.com/downloads/stihl-ms-290310390-chain-saws-service-repair-workshop-manual/>

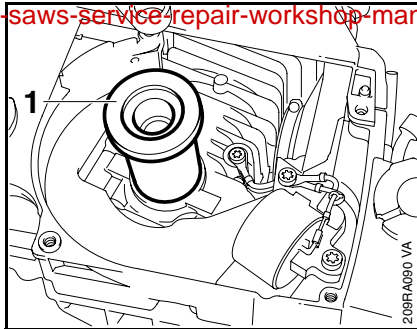

- Use press sleeve (1) 1127 893 2400 to install the “soft” oil seal.
- Wait about one minute, then rotate the crankshaft.
- Install the flywheel, 7.3

Install all other parts in the reverse sequence.

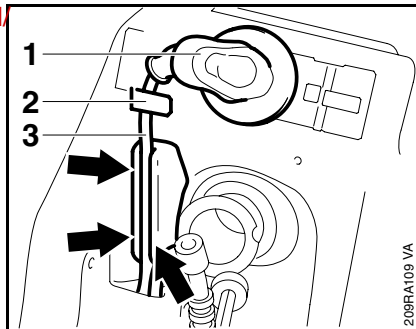

- Pull off the spark plug boot (1).
- Pull the ignition lead (3) out of the retainer (2) and guides (arrows).

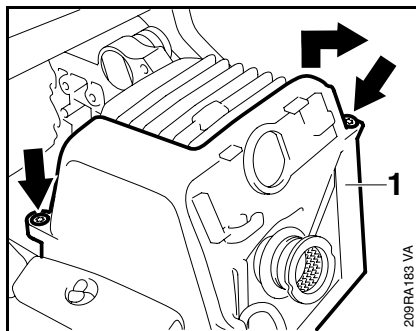

- Take out the screws (arrows).
- Lift the shroud (1) up a little and remove it to the rear.

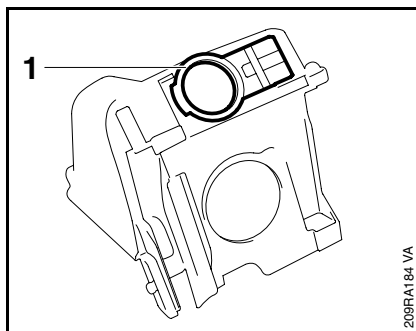

- If necessary, unclip the shutter (1).

Install in the reverse sequence.

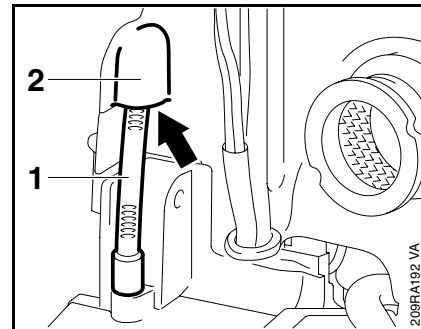

Machines up to 2001

- Push the tank vent (1) into its seat (arrow) in the shroud (2).

Sample of manual. Download All 82 pages at:

<https://www.arepairmanual.com/downloads/stihl-ms-290310390-chain-saws-service-repair-workshop-manual/>