

CONTENTS

1.	Introduction	2	5.	Ignition System	25	10.	Fuel System	42
2.	Specifications	3	5.1	Spark Plug Boot	25	10.1	Air Filter	42
2.1	Engine	3	5.2	Ignition Module	26	10.2	Pickup Body	42
2.2	Fuel System	3	5.2.1	Ignition Timing	26	10.3	Tank Vent	43
2.3	Ignition System	4	5.2.2	Removing and Installing	26	10.4	Fuel Tank/ Fuel Hose	43
2.4	Cutting Attachment	4	5.3	Flywheel	27	10.5	Carburetor	44
2.5	Special Accessories	4	5.4	Ground Wire/ Short Circuit Wire	28	10.5.1	Leakage Test	44
2.5.1	For User	4	5.5	Contact Spring	29	10.5.2	Removing and Installing	45
2.5.2	For Service	4	6.	Rewind Starter	30	10.5.3	Adjustment	45
2.6	Tightening Torques	5	6.1	General	30	10.6	Throttle Cable	46
3.	Clutch, Chain Drive, Chain Brake and Chain Tensioner	6	6.2	Fan Housing	30	10.7	Spacer Flange/ Diaphragm	47
3.1	Chain Sprocket	6	6.3	Rewind Spring	31	11.	Special Servicing Tools and Aids	48
3.2	Clutch	7	6.3.1	Replacing	31	11.1	Special Servicing Tools	48
3.3	Chain Brake	7	6.3.2	Tensioning	32	11.2	Servicing Aids	50
3.3.1	Checking Function	7	6.4	Starter Rope (ElastoStart)	32			
3.3.2	Disassembly	8	6.5	Starter Grip (ElastoStart)	33			
3.3.3	Assembly	9	7.	AV Handle System	34			
3.4	Chain Tensioner	11	8.	Master Control/ Handle System	36			
3.5	Bar Stud	11	8.1	Interlock Lever/ Throttle Trigger	36			
4.	Engine	12	8.2	Switch Shaft	36			
4.1	Removal	12	8.3	Handle Molding	37			
4.2	Assembly	13	8.4	Handlebar	37			
4.3	Exhaust Muffler/ Spark Arresting Screen	14	8.5	Top Handle	37			
4.4	Leakage Test	15	9.	Chain Lubrication	39			
4.4.1	Preparations	15	9.1	Pickup Body	39			
4.4.2	Pressure Test	16	9.2	Oil Tank/Suction Hose	39			
4.4.3	Vacuum Test (for diaphragm)	17	9.3	Oil Pump	40			
4.4.4	Vacuum Test (for oil seal)	17	9.4	Worm	41			
4.5	Oil Seals	19						
4.6	Cylinder	20						
4.7	Piston	22						
4.8	Piston Ring	23						
4.9	Crankshaft	23						



©1996, Andreas Stihl, Waiblingen

1. INTRODUCTION

This service manual contains detailed descriptions of all the repair and servicing procedures specific to this series of chainsaws. There are separate handbooks for servicing procedures on standardized parts and assemblies that are installed in several STIHL power tool models. Reference is made to these handbooks in the appropriate chapters of this manual.

You should make use of the illustrated parts lists while carrying out repair work. They show the installed positions of the individual components and assemblies.

Always use the latest edition of the parts list to determine the part numbers of any replacement parts required. Microfilmed parts list are always more up to date than printed lists.

A fault on the machine may have several causes. Consult the troubleshooting charts for all assemblies in the "Standard Repairs, Troubleshooting" handbook.

Refer to the "Technical Information" bulletins for engineering changes which have been introduced since publication of this service manual. Technical information bulletins also supplement the parts list until a revised edition is issued.

Special servicing tools mentioned in the descriptions are listed in the last chapter of this manual. Use the part numbers to identify the tools in the "STIHL Special Tools" manual. The manual lists all special servicing tools currently available from STIHL. Symbols are included in the text and pictures for greater clarity. The meanings are as follows:

In the descriptions:

- = Action to be taken as shown in the illustration (above the text)
- = Action to be taken that is not shown in the illustration (above the text)

In the illustrations:

- = Pointer
- ➔ = Direction of movement

Service manuals and all technical information bulletins describing engineering changes are intended exclusively for the use of STIHL servicing dealers. They must not be passed to third parties.

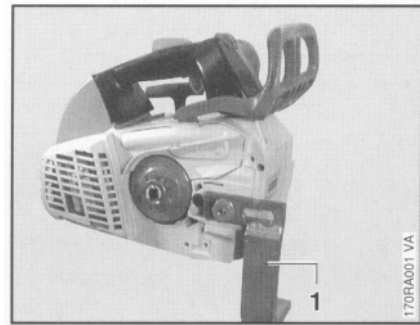

Servicing and repairs are made considerably easier if the powerhead is mounted to the assembly stand (1) 5910 890 3100.

This enables the powerhead to be swivelled to the best position for the ongoing repair and leaves both hands free.

It is secured with the bar mounting stud after removing the chain sprocket cover and tensioner.

Always use original STIHL replacement parts. They can be identified by the STIHL part number, the **STIHL** logo and the STIHL parts symbol . The symbol may appear alone on small parts.

2. SPECIFICATIONS

2.1 Engine

STIHL single cylinder two-stroke engine with special impregnated cylinder bore

Displacement:	35.2 cm ³ (2.15 cu.in)
Bore:	40 mm (1.57 in)
Stroke:	28 mm (1.10 in)
Engine power to ISO 8893:	1.2 kW (1.6 bhp)
Max. engine speed with bar and chain:	12,000 rpm
Idle speed:	2,800 rpm
Bearings:	Crankshaft supported in heavy-duty ball bearings, needle cages on small and big ends
Piston pin diameter:	8 mm (0.3 in)
Connecting rod length:	51 mm (2 in)
Rewind starter:	Single pawl system
Reserve pull on rope rotor:	min. 1/2 turn
Starter rope:	3.0 mm (0.12 in) dia., 800 mm (31.5 in) long
Clutch:	Centrifugal clutch without linings
Diameter:	64 mm (2.52 in)
Clutch engages at:	3,700 rpm
Crankcase leakage test at gauge pressure:	0.5 bar (7.25 psi)
under vacuum:	0.4 bar (5.8 psi)

2.2 Fuel System

Carburetor:	Diaphragm carburetor
Standard setting	
High speed screw H:	Open approx. 1 turn
Low speed screw L:	Open approx. 1 turn
Carburetor leakage test at gauge pressure:	0.4 bar (4.8 psi)
Fuel tank capacity:	0.29 l (0.61 US pt)
Octane number:	min. 90 RON (US/CAN: pump octane min. 87 unleaded)
Fuel mixture:	Regular brand-name gasoline and two-stroke engine oil
Mix ratio:	1:50 with STIHL 50:1 two-stroke engine oil 25:1 with other brand-name two-stroke, air-cooled engine oils
Air filter:	Felt element

2.3	Ignition System	Type:	Electronic magneto ignition (breakerless) with integral trigger unit
		Air gap:	0.25 mm (0.010 in)
		Ignition timing:	1.6 - 2.3 mm (0.063-0.091 in) B.T.D.C. at 8,000 rpm
		Spark plug (suppressed):	NGK BPMR 7 A or CHAMPION RCJ6Y
		Electrode gap:	0.5 mm (0.02 in)
		Spark plug thread:	M14x1.25
		Length of thread:	9.5 mm (0.37 in)
<hr/>			
2.4	Cutting Attachment	Oilomatic chain:	9.32 mm (3/8") Picco-Micro-Mini
		Chain sprocket:	7-tooth 3/8" P spur sprocket
		Chain speed:	21.7 m/s (71.2 ft/sec) at 10,000 rpm
		Chain lubrication:	Speed-controlled reciprocating oil pump. No oil feed at idle speed
		Oil delivery rate:	Adjustable 5 - 9 cm ³ /min (0.17 - 0.30 fl.oz/min)
		Oil tank capacity:	0.16 l (0.34 US pt)
<hr/>			
2.5	Special Accessories		
2.5.1	For User	STIHL repair kit	1132 900 5000
		6-tooth 3/8" P spur sprocket	1123 640 2005
		8-tooth 1/4" spur sprocket	1123 640 2010
		ElastoStart	0000 190 3400
2.5.2	For Service	Carburetor parts kit	1132 007 1060
<hr/>			

2.6 Tightening Torques

Plastoform screws are used for polymer components and "DG" screws for lightmetal components. These screws form a permanent thread when they are installed for the first time. They can be removed and installed as often as necessary without detrimentally affecting the strength of the screwed assembly, providing the specified tightening torque is observed. For this reason it is **essential to use a torque wrench**.

Fastener	Thread size	For component	Torque		Remarks
			Nm	lbf.ft	
Spline screw	IS-DG 4x20	Ignition module/cylinder	4.5	3.3	
Spline screw	IS-DG 5x24	Handle molding/front handle	3.5	2.6	
Spline screw	IS-DG 5x24	Fan housing/engine housing	4.0	3.0	
Spline screw	IS-DG 5x24	Engine pan/cylinder	8.0	5.9	
Spline screw	IS-DG 5x24	Handle molding/handle	4.0	3.0	
Spline screw	IS-DG 5x24	Muffler/cylinder	7.0	5.2	
Spline screw	IS-DG 5x24	Spacer flange/cylinder	8.0	5.9	
Spline screw	IS-DG 5x24	Engine housing/cylinder	8.0	5.9	
Collar screw	IS-DG 8x18	Bar mounting/engine housing	16.0	11.8	
Spline screw	IS-M5x52	Intake casing/carburetor/flange	5.0	3.7	
Collar nut	M8x1	Flywheel	28.0	21.0	
	M12x1 L	Clutch	50.0	37.0	
	M14x1.25	Spark plug	25.0	18.5	
Plastoform screw	IS-P4x12	Hand guard, left/fan housing	1.7	1.3	
Screw	IS-DG 3.5x12	Support plate /diaphragm/ spacer flange	2.0	1.5	

Use the following procedure when refitting a P or DG screw in an existing thread:

- Place the screw in the hole and rotate it counterclockwise until it drops down slightly.
- Tighten the screw clockwise to the specified torque.

This procedure ensures that the screw engages properly in the existing thread and does not form a new thread and weaken the joint.

Note: Power screwdriver speed for use in polymer: Plastoform screws max. 600 rpm,
DG screws max. 500 rpm.

Use only screws specified in parts list.
Do not use screws with underhead locking teeth on polymer components.

3. CLUTCH, CHAIN DRIVE, CHAIN BRAKE AND CHAIN TENSIONER

3.1 Chain Sprocket

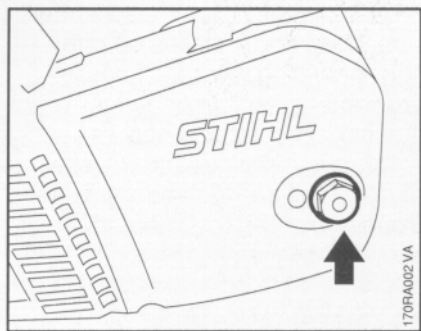

- Unscrew the nut.
- Pull off the chain sprocket cover.
- Disengage the chain brake by pulling the hand guard toward the front handle.

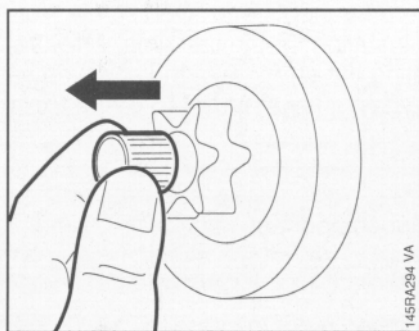

- Take the needle cage out of the sprocket.
- Clean and inspect the chain sprocket.

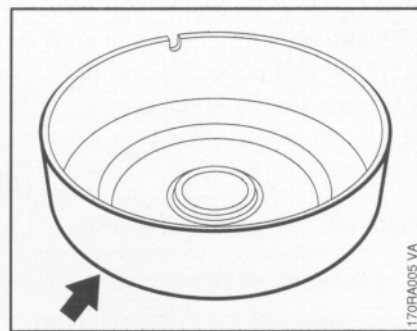

- If the clutch drum is still serviceable, use No. 120 emery paper or emery cloth (grain size approx. 120µm) to clean and roughen its friction surface.

Reassemble in the reverse sequence.

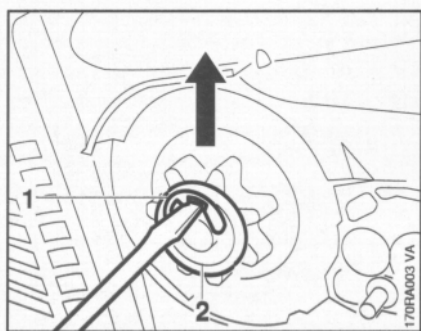

- Remove the E-clip (1).
- Remove the washer (2).

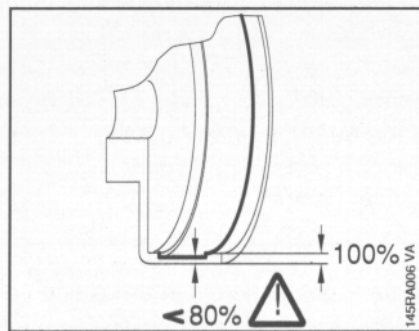

Important: If there are noticeable wear marks on the inside diameter of the clutch drum, check its wall thickness. If it is less than 80% of the original wall thickness, fit a new sprocket.

Note: If the clutch drum has to be replaced, also check the brake band - see 3.3.2.

- Clean stub of crankshaft. Wash needle cage in clean white spirit and lubricate with grease - see 11.2.

- Replace damaged needle cage.

- Rotate chain sprocket and apply slight pressure at the same time until oil pump drive spring engages properly.

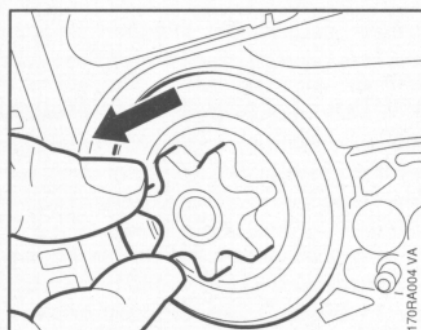

- Pull off the chain sprocket.

3.2 Clutch

Troubleshooting chart - see "Standard Repairs, Troubleshooting" handbook.

- Remove chain sprocket - see 3.1.

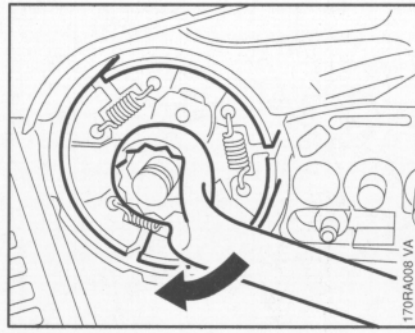

- Unscrew the clutch from the crankshaft in the direction of the arrow (left-hand thread).
- Disassemble and reassemble the clutch - see "Standard Repairs, Troubleshooting" handbook.

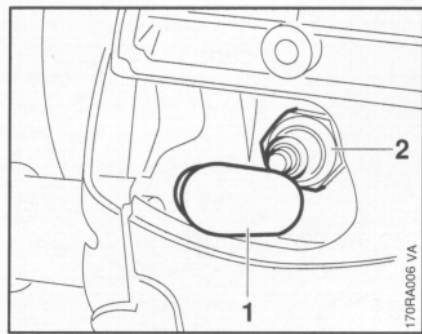

- Pull boot (1) off the spark plug.
- Unscrew the spark plug (2).

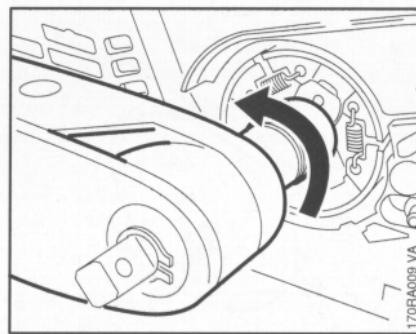

- Screw clutch onto crankshaft and torque down to 50 Nm (37 lbf.ft).
- Remove locking strip from cylinder.
- Install spark plug and torque down to 25 Nm (18.5 lbf.ft).

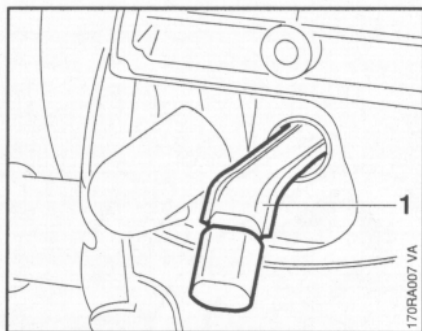

- Push the locking strip (1) 0000 893 5903 into the cylinder.

3.3 Chain Brake 3.3.1 Checking Function

The chain brake is one of the most important safety devices on the chainsaw. Its efficiency is measured in terms of braking time, i.e. the time that elapses between activating the brake and the saw chain coming to a standstill. The shorter the braking time, the better the efficiency and protection offered against being injured by the rotating chain.

Contamination (with chain oil, chips, fine particles of abrasion, etc.) and smoothing of the friction surfaces of the brake band and clutch drum impair the coefficient of friction. This, in turn, reduces the frictional forces and thus prolongs the braking time. A fatigued or stretched brake spring has the same negative effect.

- Start the engine.
- With the chain brake activated (locked), open throttle wide for brief period (max. 3 seconds) the chain must not rotate.
- With the chain brake released, open throttle wide and activate the brake manually - the chain must come to an abrupt stop.

Note: The braking time is in order if deceleration of the saw chain is imperceptible to the eye.

Important: If spark plug has a separate terminal nut, make sure that it is properly tightened down.

- Fit spark plug boot.
- Install the chain sprocket - see 3.1.

3.3.2 Disassembly

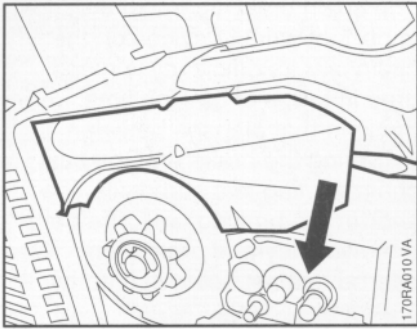

- Release tension of brake spring by pushing the hand guard forwards.
- Remove chain sprocket cover.
- Ease the cover out of its retainers.

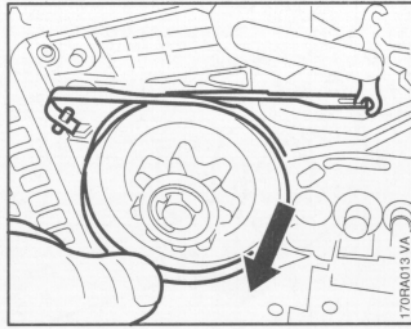

- Remove brake band from the chain sprocket and detach it from the bell crank.

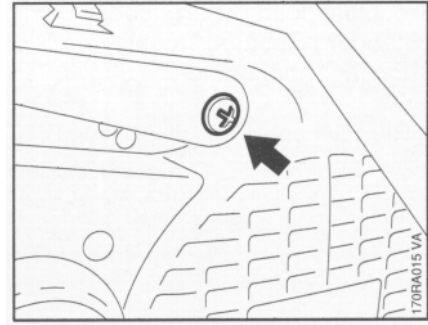

- Take out the screw.
- Remove the hand guard from its seat on the fan housing.

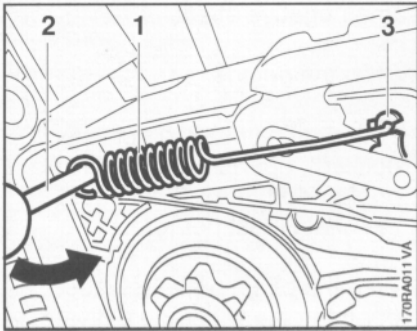

- Use assembly tool (2) 1117 890 0900 to carefully disconnect the brake spring (1).
- Unhook the brake spring from the bell crank (3).

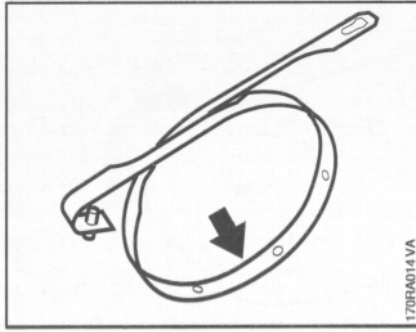

Replace the brake band if:

- there are noticeable signs of wear (large areas on inside diameter and/or parts of outside diameter) and
- its remaining thickness is less than 0.6 mm (0.024").

Important! Thickness of brake band must not be less at **any** point.

- If the brake band is still serviceable, use No. 120 emery paper or emery cloth (grain size approx. 120µm) to clean and roughen its entire friction surface (inside diameter).

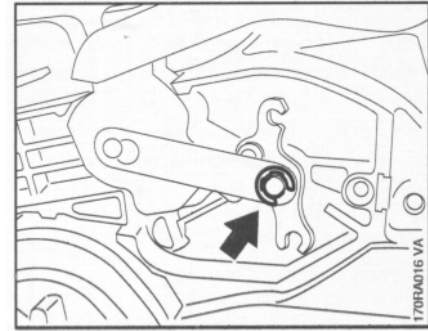

- Remove the E-clip,

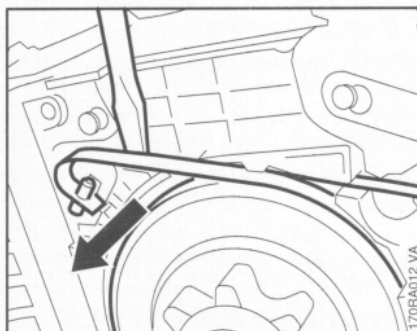

- Lever the brake band out of the engine housing.

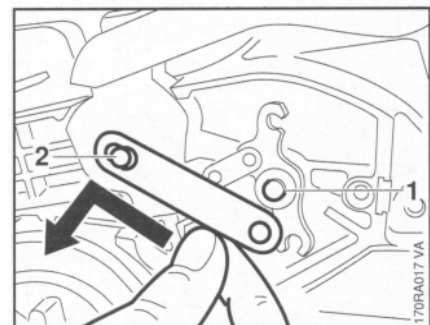

- Slip the strap off the bell crank pivot pin (1).
- Push the strap to one side and remove it from the hand guard pivot pin (2).

3.3.3 Assembly

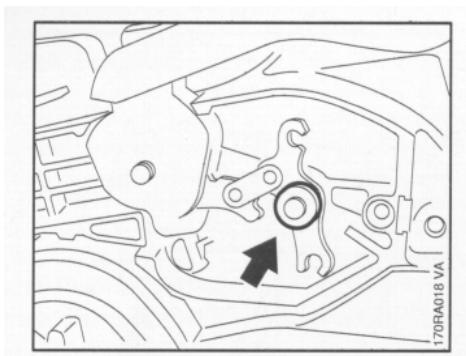

- Clean chain brake seat in housing.
- If the groove of the brake spring anchor pin is worn, replace the housing.

- Lubricate sliding and bearing points of chain brake with STIHL multipurpose grease or, preferably, Molykote grease - see 11.2.
- Fit flat spring in position.

- Remove the washer.

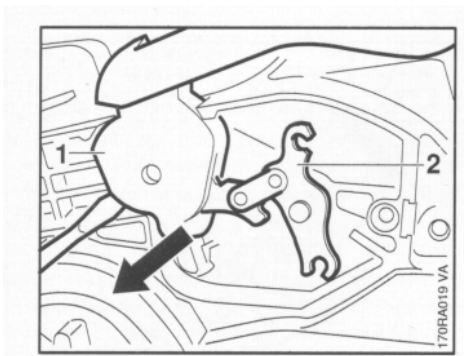

- Carefully ease the hand guard (1) and bell crank (2) off the pivot pins and lift them away together.
- Pull the bell crank out of the hand guard.

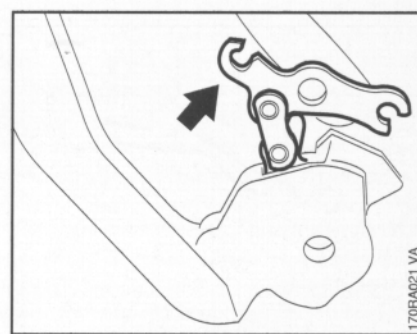

- Slide bell crank into end of hand guard. The short arm of the bell crank must point to top of hand guard.

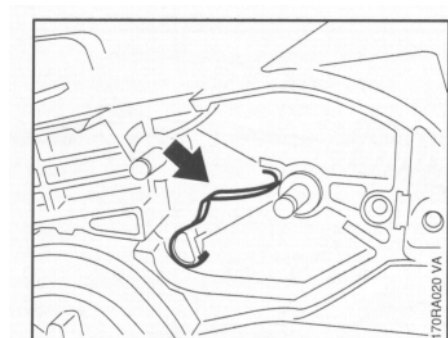

- Take out the flat spring.
- Inspect parts. Replace any worn or damaged parts.

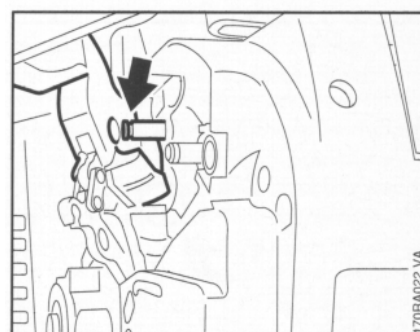

- Locate bearing boss of hand guard (1) on pivot pin.
- Fit other end over the housing.

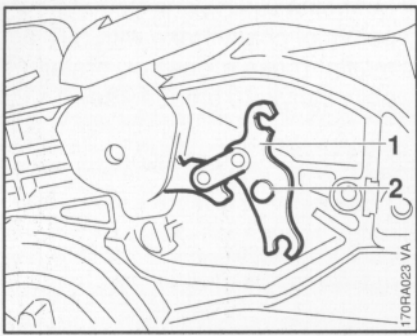

- Position bell crank (1) against pivot pin (2).
- Push hand guard and bell crank fully onto the pivot pins.

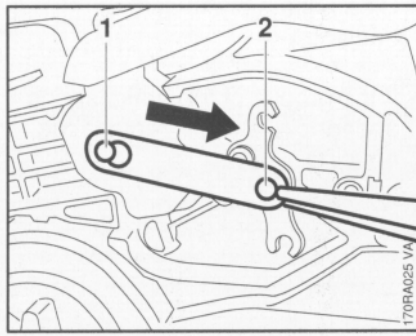

- Place strap on pivot pin (1) and pull it in direction of arrow until it engages the groove.
- Then push it over the pivot pin (2).

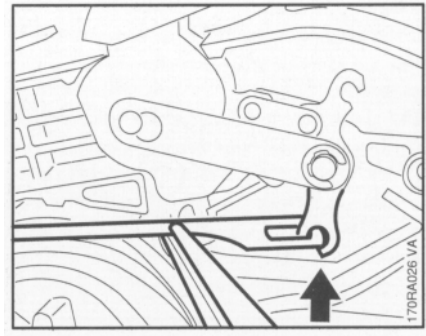

- Attach brake band to the bell crank.

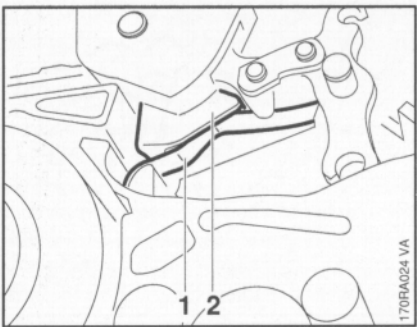

- Check that flat spring (1) is properly located on face (2) of bearing boss.

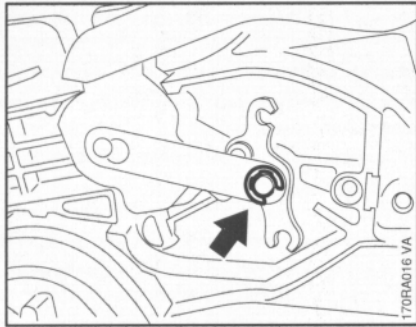

- Secure strap with E-clip.
- Coat brake band with chain oil (STIHL Bioplus), see 11.2, to protect it from corrosion and cushion "snatching" during the first few brake applications.

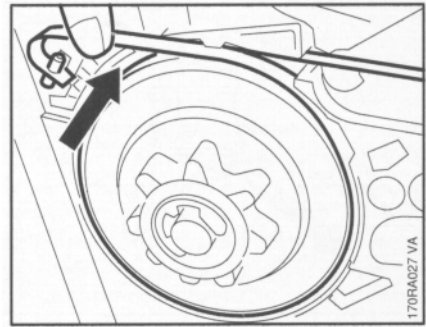

- Fit the brake band and press it into the engine housing.

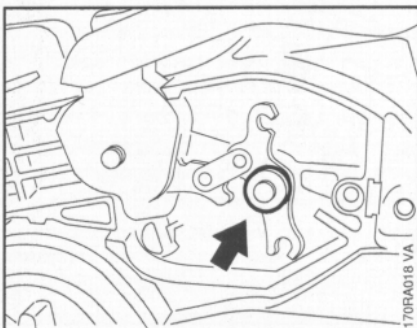

- Fit the washer.

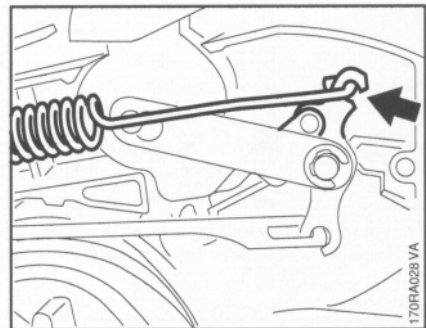

- Hook the brake spring onto the bell crank.

3.4 Chain Tensioner

3.5 Bar Stud

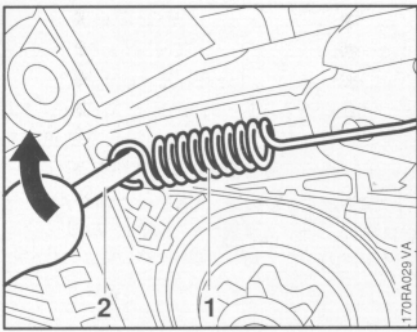

- Use the assembly tool (2) 1117 890 0900 to attach the brake spring (1) to the anchor pin.

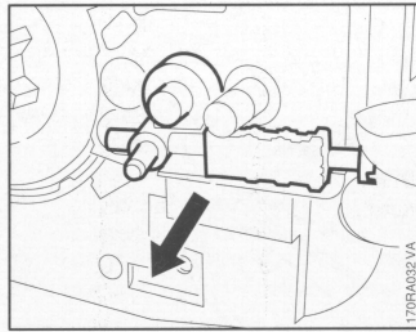

- Remove the chain sprocket cover.
- Pull the cover out of the engine housing.

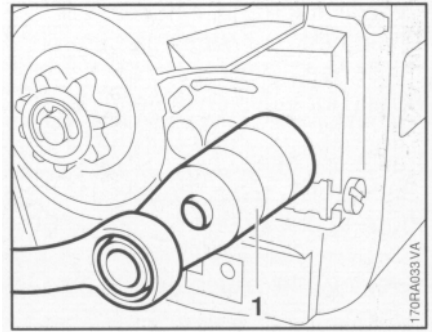

- Remove the chain sprocket cover.
- Push the stud puller (1) 5910 893 0501 onto the stud as far as it will go.
- Unscrew the stud.
- Insert stud and torque down to 16 Nm (11.8 lbf.ft).

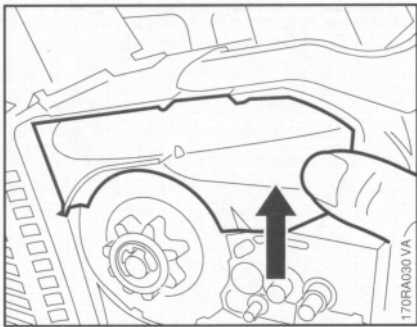

- Push cover over chain brake until it snaps into position and then tap it home carefully with a plastic mallet.

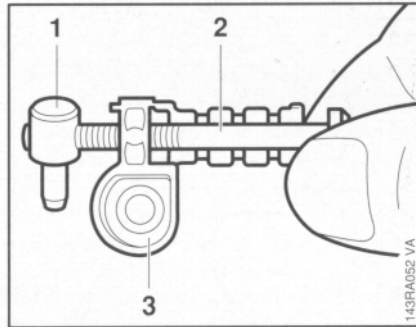

- Unscrew the nut (1) from the adjusting screw (2).
- Take the adjusting screw out of the cover (3).

Reverse the above sequence to install the chain tensioner.

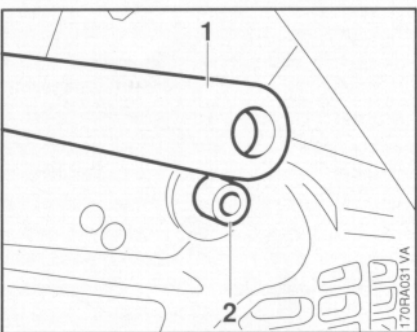

- Fit hand guard (1) over boss (2) on the fan housing.
- Insert screw and tighten to 1.7 Nm (1.25 lbf.ft).

4. ENGINE
4.1 Disassembly

Always check and, if necessary, repair the fuel system, carburetor, air filter and ignition system before looking for faults on the engine.

Troubleshooting chart - see "Standard Repairs, Troubleshooting" handbook.

- Remove the clutch - see 3.2.
- Take the locking strip out of the cylinder.

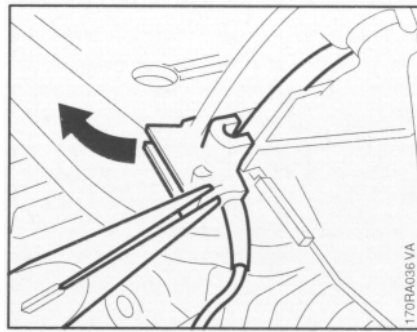

- Open the grommet.

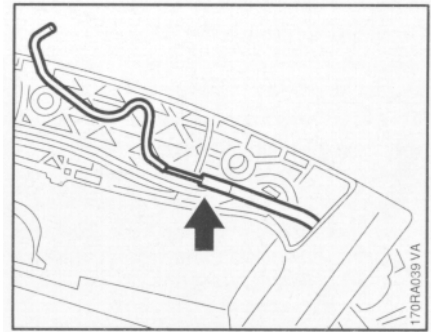

- Take throttle cable out of retainer.

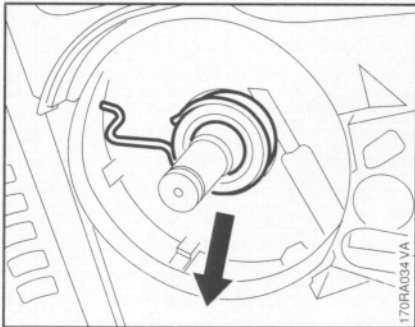

- Pull off the worm with drive spring.
- Remove throttle trigger - see 8.1.

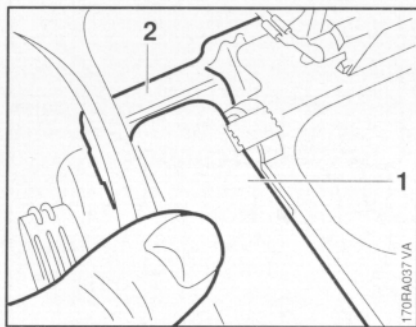

- Pull intake pipe (1) out of the intake casing (2).

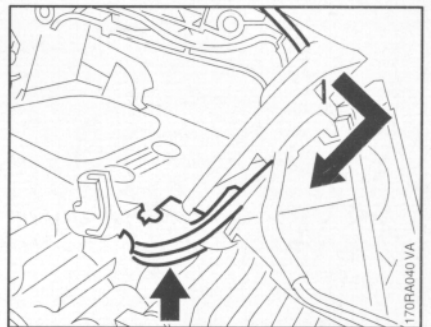

- Remove throttle cable from grommet and pull it downwards and out of the handle.

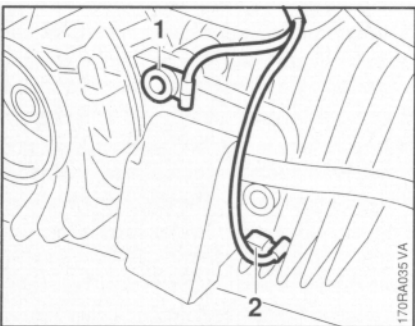

- Take out the upper screw (1).
- Disconnect the short circuit wire (2).



- Pull intake pipe with grommet out of engine housing.
- Remove the grommet.

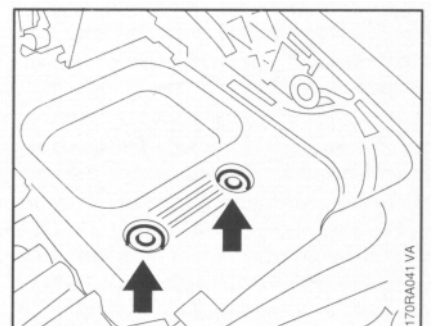

- Take out screws from top of engine.

4.2 Assembly

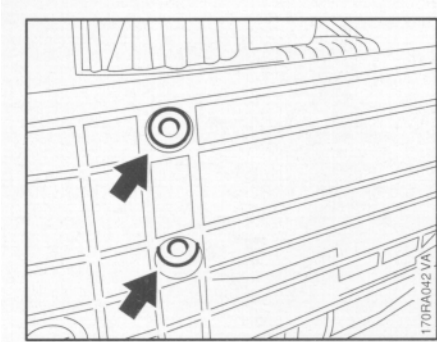

- Take out screws from underside of engine.

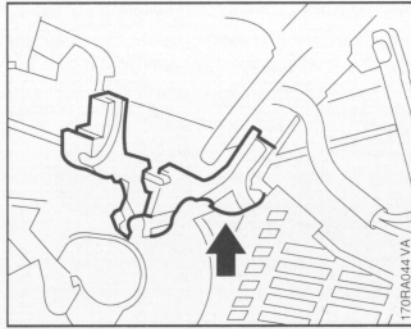

- Check that grommet is properly seated in the engine housing.

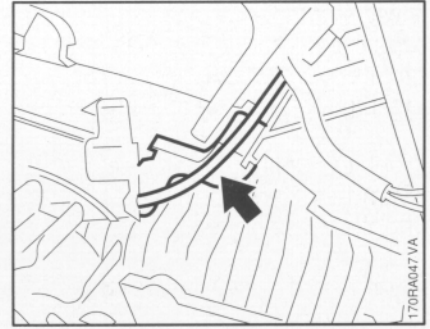

- Place throttle cable in the grommet.
- Fit top and bottom engine mounting screws and torque down to 8.0 Nm (5.9 lbf.ft).

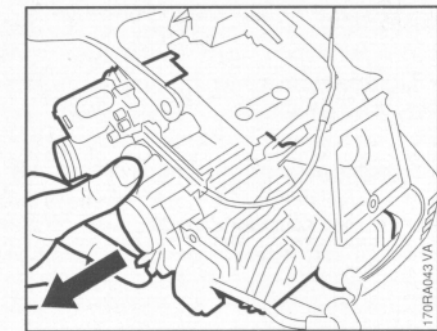

- Remove engine sideways from housing.

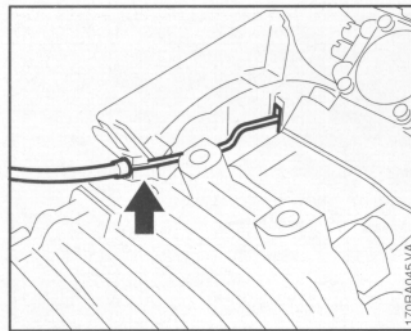

- Throttle cable sleeve must locate in retainer in air baffle.

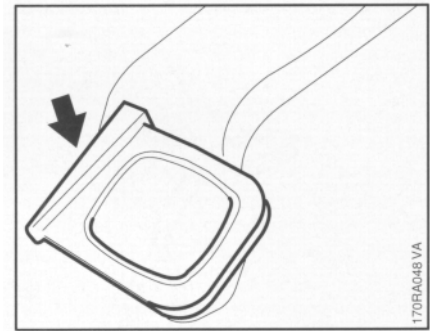

- Push grommet, ledge facing up, over the lugs of the intake pipe.



- Fit engine and position throttle cable in the handle at the same time.
- Push throttle cable into retainer in handle.

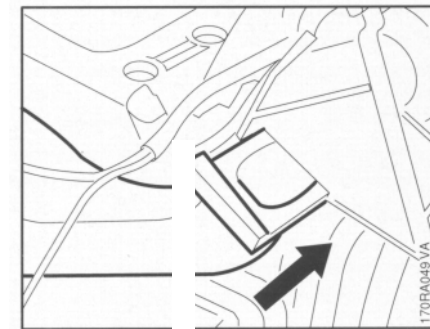

- Push grommet with intake pipe into the engine housing until the ledge butts against the engine housing.

4.3 Exhaust Muffler/Spark Arresting Screen

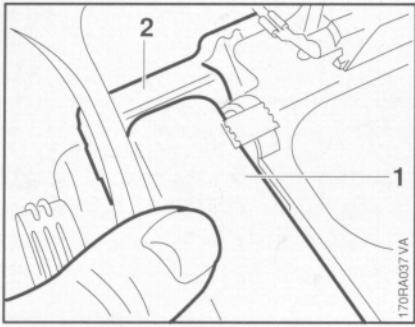

- Fit the intake pipe (1) in the intake casing (2).

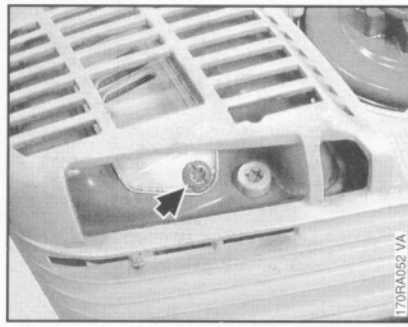

Spark arresting screen

- Take out the screw.

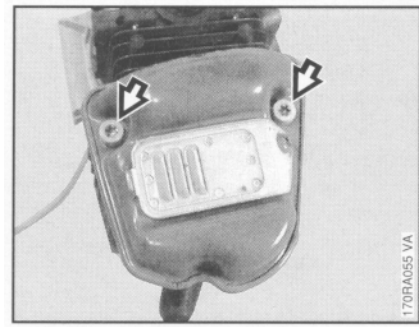

Muffler

- Remove the engine - see 4.1.
- Take out the screws.
- Remove the muffler.

Reassemble in the reverse sequence.

- Tighten screws to 7.0 Nm (5.2 lbf.ft).
- Install the engine - see 4.2.

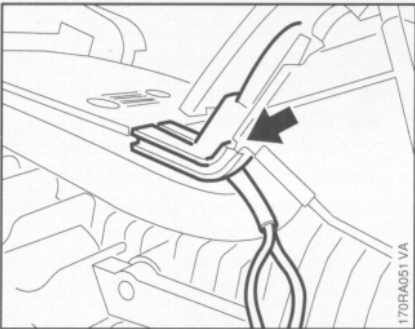

- Fit the short circuit and ground wires (pull them downward and out of handle as far as possible) in the grommet and close the grommet.

- Connect short circuit and ground wires to ignition module.
- Fit throttle trigger - see 8.1.
- Fit the worm with drive spring in position.
- Install the clutch - see 3.2.

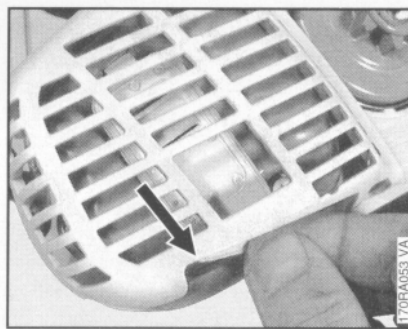

- Remove the cover plate.

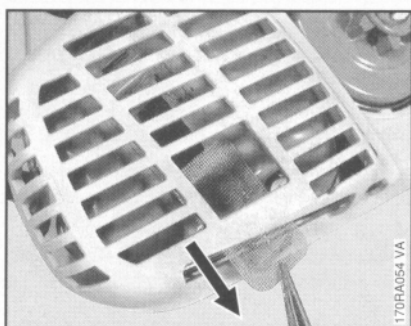

- Remove the spark arresting screen.
- Clean the spark arresting screen or fit a new one if necessary.

4.4 Leakage Test

Defective oil seals, diaphragms and gaskets or cracks in castings or the spacer flange cause leaks. Such faults allow supplementary air to enter the engine and thus upset the fuel-air mixture.

This makes adjustment of the prescribed idle speed difficult, if not impossible.

Moreover, the transition from idle speed to part or full throttle is not smooth.

The engine housing can be checked thoroughly for leaks with the carburetor and crankcase tester and the vacuum pump.

4.4.1 Preparations

- Remove the carburetor - see 1 0.5.2.
- Set the piston to top dead center (T.D.C.). This can be checked through the spark plug hole.
- Remove the air baffle - see 10.6.

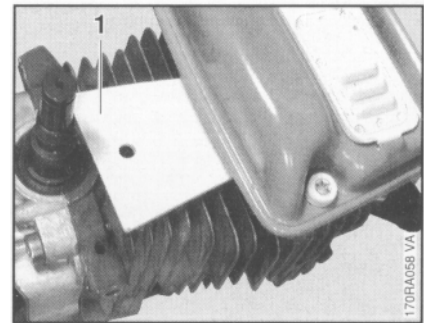

- Fit the sealing plate (1) 0000 855 8106 between muffler and cylinder.

Note: The sealing plate must completely cover the exhaust port.

- Tighten the screws moderately.

Important: Do not overtighten the screws since the sealing plate may otherwise be damaged.

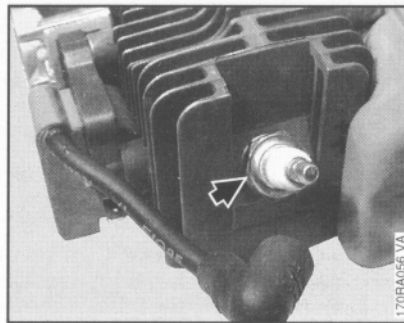

- Fit the spark plug and tighten down to 25 Nm (18.5 lbf.ft).

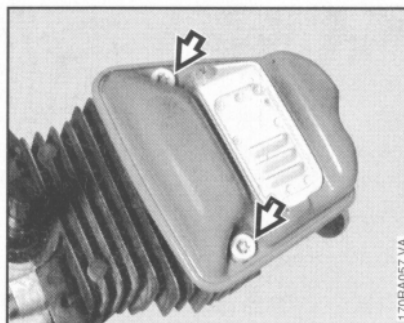

- Back off muffler mounting screws halfway.

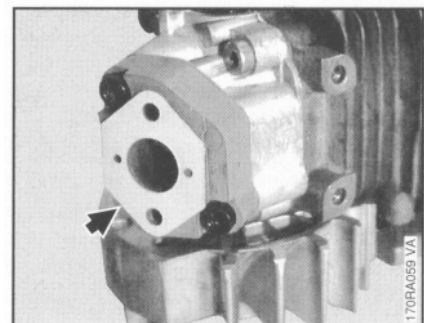

- Fit new gasket on spacer flange.

4.4.2 Pressure Test

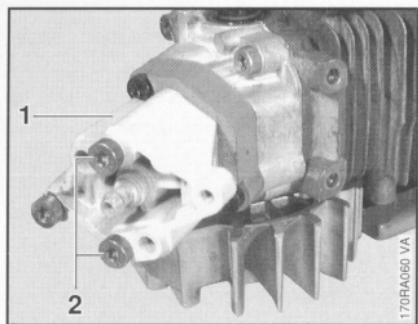

- Use carburetor screws (2) to mount the test flange (1) 1128 850 4200 to spacer flange.

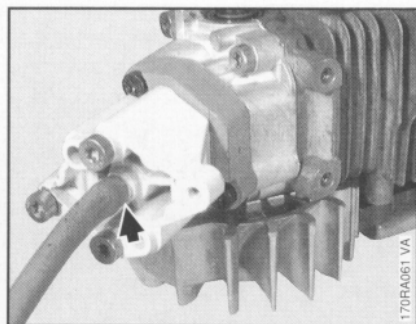

- Connect pressure hose of tester 1106 850 2905 to nipple on test flange.

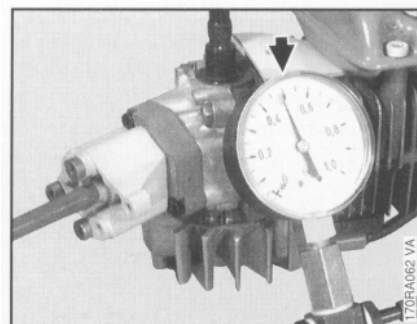

- However, if the indicated pressure drops, the leak must be located and the faulty part replaced.

Note: To find the leak, coat the suspect area with oil and pressurize the engine housing again. Bubbles will appear if a leak exists.

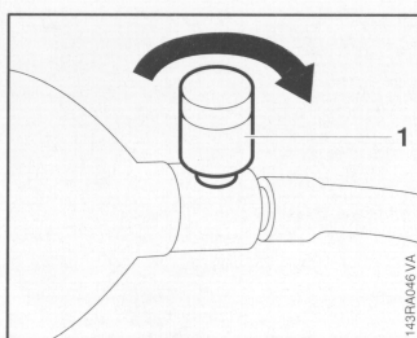

- Close the vent screw (1) on the rubber bulb.
- Continue squeezing rubber bulb until the gauge indicates a pressure of 0.5 bar (7.25 psi). If this pressure remains constant for at least 20 seconds, the engine housing is airtight.

- Carry out the vacuum test - see 4.4.3 and 4.4.4.
- After finishing the test, open the vent screw and disconnect the hose.
- Remove the test flange.
- Loosen muffler mounting screws.
- Take out the sealing plate and tighten the screws to 7.0 Nm (5.2 lbf.ft).
- Install the carburetor - see 10.5.2.

4.4.3 Vacuum Test (for diaphragm)

In these chainsaws the fuel-air mixture is sucked into the crankcase via a diaphragm valve. This valve closes to prevent the gas mixture flowing back into the carburetor.

If the diaphragm seating face on the spacer flange is dirty or the diaphragm is fatigued or faulty, the mixture may flow back and result in an irregular running behavior.

A test can be carried out with the vacuum pump to detect this kind of fault. The preparations for this test are the same as for the pressure test - see 4.4.1.

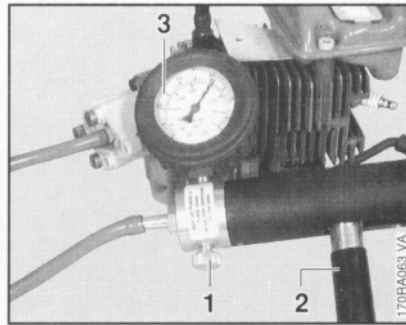

- Close the vent screw (1) on the pump.
- Operate lever (2) until pressure gauge (3) indicates a vacuum of 0.4 bar (5.8 psi).

Note: If the vacuum reading remains constant, or rises to no more than 0.3 bar (4.25 psi) within 20 seconds, it can be assumed that the spacer flange and the diaphragm are in good condition. However, if the pressure continues to rise, the spacer flange or the diaphragm must be replaced.

- After finishing the test, open the vent screw.
- Carry out vacuum test for oil seals - see 4.4.4.

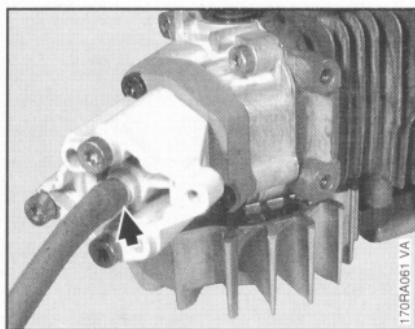

- Connect suction hose of vacuum pump 0000 850 3501 to test flange nipple.

4.4.4 Vacuum Test (for oil seal)

Oil seals tend to fail when subjected to a vacuum, i.e. the sealing lip lifts away from the crankshaft during the piston's induction stroke because there is no internal counterpressure.

An additional test can be carried out with the vacuum pump to detect this kind of fault.

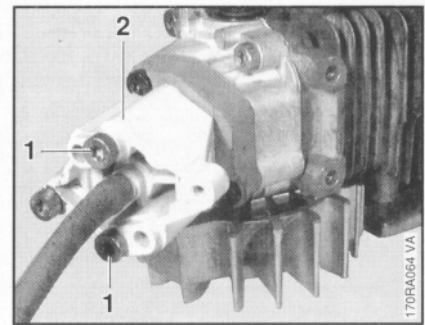

- Take out the screws (1).
- Remove the test flange (2) and gasket.

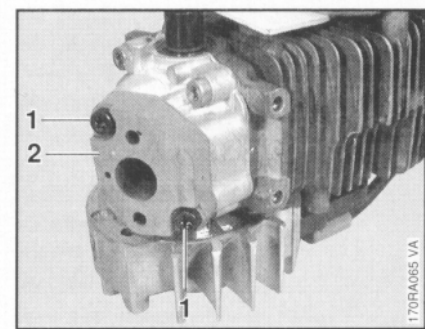

- Take out the screws (1).
- Remove the spacer flange (2) and gasket.

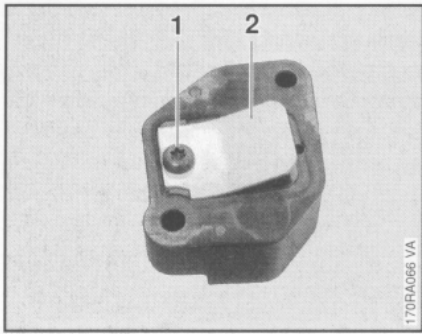

- Take out the screw (1).
- Remove the support plate (2).

- Fit test flange with suction hose of vacuum pump 0000 850 3501 to the spacer flange.

- Remove the spacer flange.
- Fit the diaphragm and support plate - see 10.7.
- Fit the spacer flange - see 10.7.
- Loosen muffler mounting screws.
- Take out the sealing plate and tighten the screws to 7.0 Nm (5.2 lbf.ft).
- Install the carburetor - see 10.5.2.

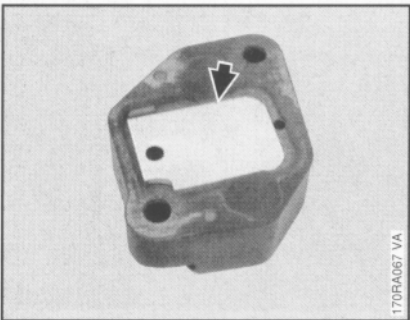

- Remove the diaphragm.

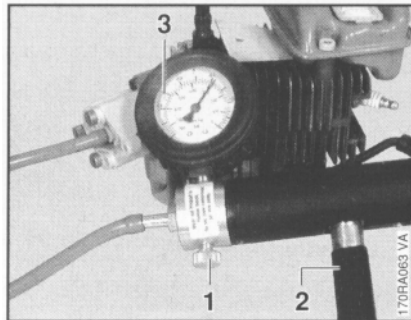

- Close the vent screw (1) on the pump.
- Operate lever (2) until pressure gauge (3) indicates a vacuum of 0.4 bar (5.8 psi).

Note: If the vacuum reading remains constant, or rises to no more than 0.3 bar (4.25 psi) within 20 seconds, it can be assumed that the oil seals are in good condition. However, if the pressure continues to rise, the oil seals must be replaced

- After finishing the test, open the vent screw and disconnect the hose.
- Remove the test flange.

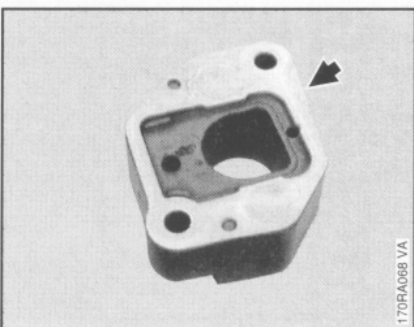

- Check that gasket is in good condition or fit new one if necessary.
- Fit spacer flange, insert screws and tighten down to 8.0 Nm (5.9 lbf.ft).

4.5 Oil Seals

It is not necessary to disassemble the engine to replace the oil seals.

- Remove the fuel tank - see 10.4.

Important: Take special care not to damage crankshaft stub.

- Thinly coat the outside diameter of the oil seal with sealant - see 11.2.

- Position the oil seal so that the clamping ring faces upwards.

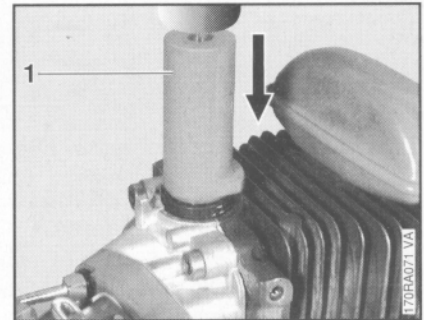
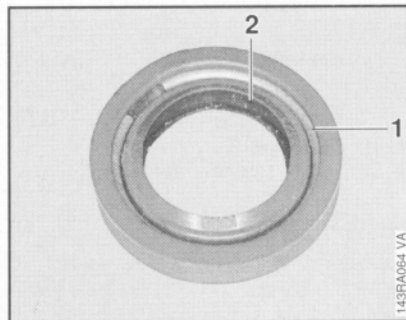
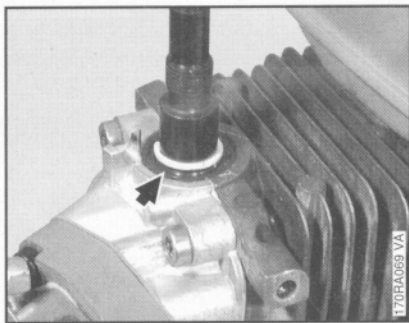

Clutch side:

- Pry out the retaining ring.

- If an oil seal with clamping ring (1) is installed, use puller and No. 3.1 jaws to remove the clamping ring. Pry the sealing ring (2) out of the housing.

- Clean sealing face on crankshaft stub with standard commercial, solvent-based degreasant containing no chlorinated or halogenated hydrocarbons - see 11.2.

- Use the press sleeve (1) 1123 893 2400 to install the oil seal.

- Fit a new retaining ring in the crankshaft groove.

- Fit the fuel tank.

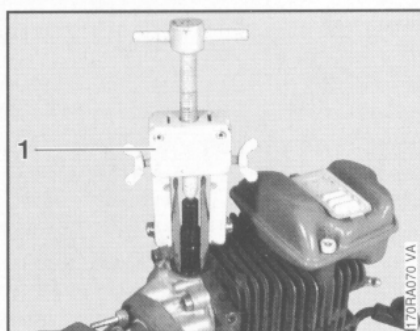

Note: If the cylinder and engine pan are assembled, only oil seals 9638 003 1581 (with clamping ring) may be installed.

- Lubricate sealing lips of oil seal with grease - see 11.2.

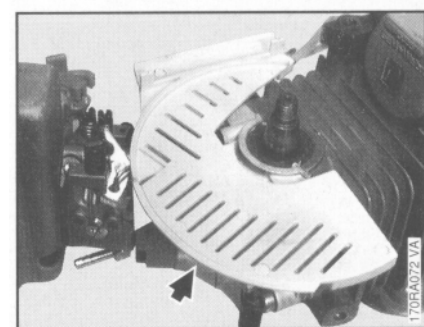

- Apply puller (1) 5910 890 4400 (jaws 0000 893 3706 with No. 3.1 profile).

- Clamp the puller arms.

- Pull out the oil seal.

Starter side:

- Remove the flywheel - see 5.3.

- Remove the air baffle.

4.6 Cylinder

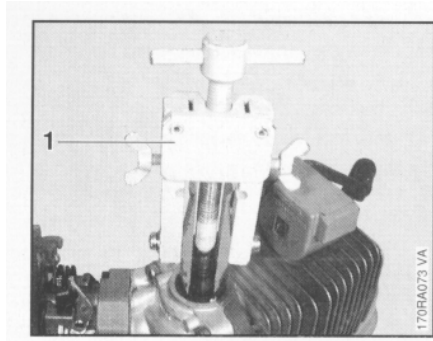

- Apply puller (1) 5910 890 4400 (jaws 0000 893 3706 with No. 3.1 profile).
- Clamp the puller arms.
- Pull out the oil seal.

Important: Take special care not to damage crankshaft stub.

Note: Remove the oil seal with clamping ring as described for clutch side.

- Clean sealing face on crankshaft stub with standard commercial, solvent-based degreasant containing no chlorinated or halogenated hydrocarbons - see 11.2.

Note: Only install oil seal 9638 003 1581 (with clamping ring).

- Lubricate sealing lips of oil seal with grease - see 11.2.
- Thinly coat the outside diameter of the oil seal with sealant - see 11.2.
- Position the oil seal so that the clamping ring faces upwards.

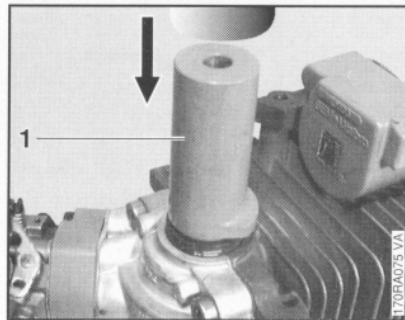

- Use the press sleeve (1) 1123 893 2400 to install the oil seal.
- Unscrew the guide.
- Place air baffle in position and fit throttle cable in throttle trigger at the same time. Check that it has engaged properly.
- Install the flywheel - see 5.3.
- Install the engine - see 4.2.

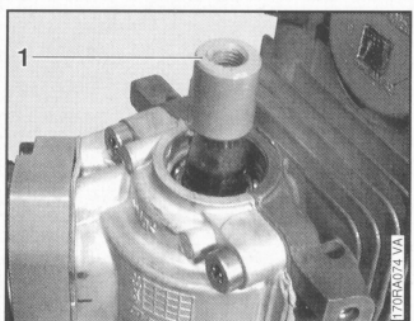

- Screw guide (1) 1123 894 7700 onto crankshaft stub.

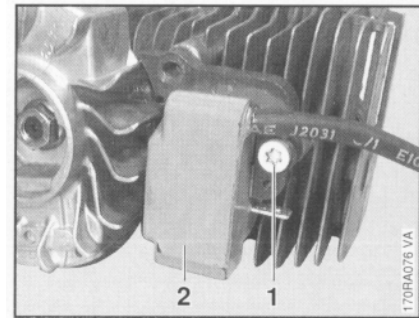

- Remove the muffler - see 4.3.
- Remove the carburetor - see 10.5.2.
- Take out the screw (1).
- Remove the ignition module (2).

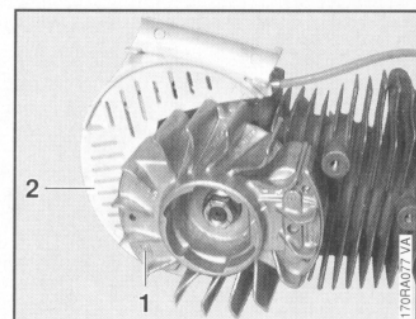

- Remove the flywheel (1) - see 5.3.
- Remove the air baffle (2).

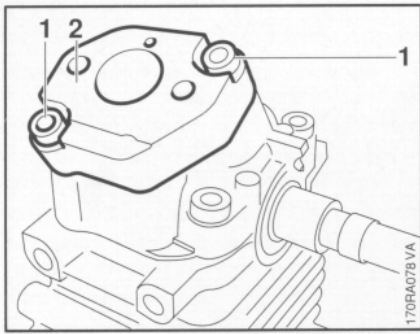

- Take out the screws (1).
- Remove the spacer flange (2).

- Inspect the cylinder and replace it if necessary.
- If a new cylinder has to be installed, always fit the matching piston. Replacement cylinders are only supplied complete with piston for this reason.
- Thoroughly clean all residue of sealant from the cylinder and engine pan mating faces.
- Lubricate piston and piston ring with oil.

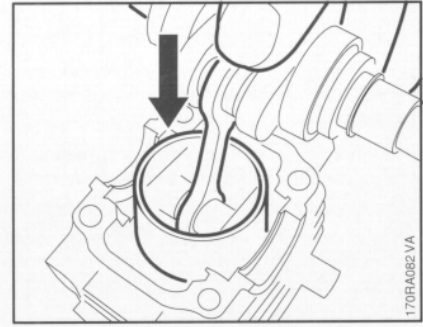

- Slide piston carefully into the cylinder.

Note: The piston ring is compressed by the inner taper of the cylinder.

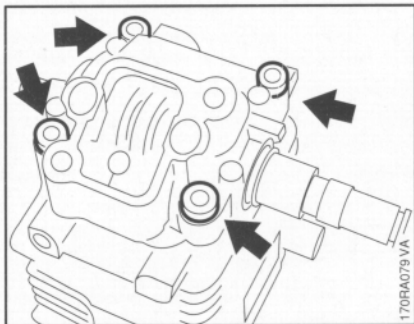

- Take out the screws.
- Pull the engine pan off the cylinder.

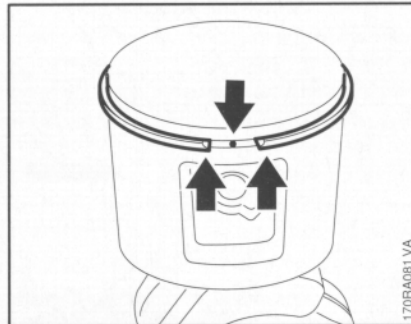

- Position the piston ring so that the radii at the ring gap meet at the fixing pin in the piston groove when the ring is compressed.
- Apply a thin coating of sealant to the outer diameters of the oil seals, - see 11.2.

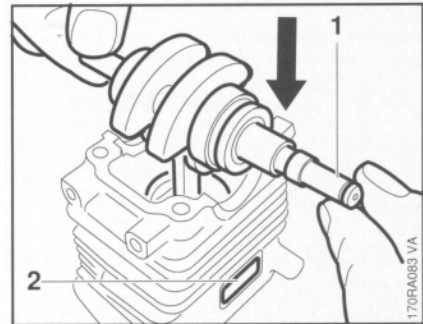

- Line up the crankshaft so that the long crankshaft stub (1) is on the same side as the exhaust port (2).
- Push piston home until ball bearings are seated.

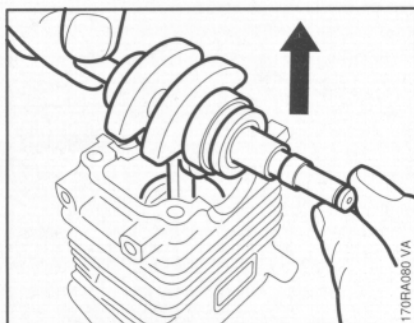

- Lift the crankshaft and pull the piston out of the cylinder.
- Inspect ball bearings and oil seals and replace if necessary - see 4.9.

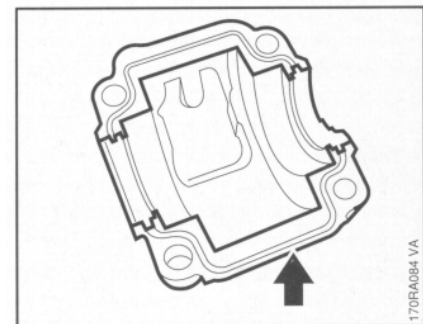

- Apply a thin bead of sealant to the engine pan mating face, see 11.2.

Note: Follow manufacturer's instructions for use of sealant.

4.7 Piston

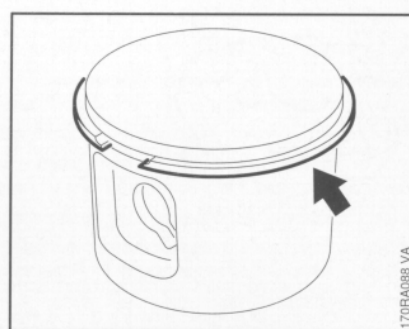
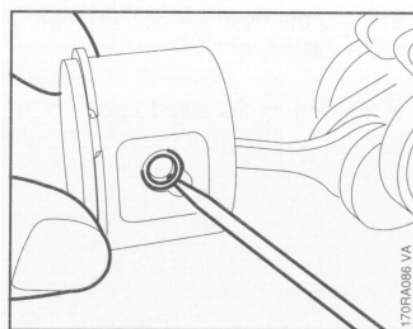
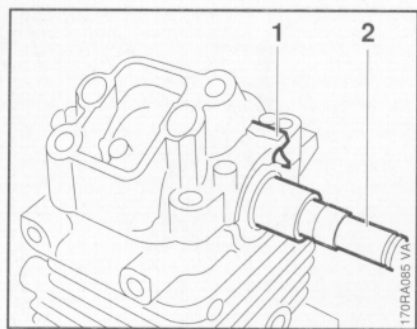

- Fit the engine pan so that the seat (1) for the oil pump is at the same side as the long crankshaft stub (2).
- Insert screws and torque down to 8.0 Nm (5.9 lbf.ft).
- Fit the spacer flange - see 10.7.
- Fit the air baffle.
- Install the flywheel - see 5.3.
- Install and adjust the ignition module - see 5.2.
- Install the carburetor - see 10.5.2.
- Install the muffler - see 4.3.
- Install the engine - see 4.2.

- Pull the piston out of the cylinder - see 4.6.

- Ease the hookless snap rings out of the grooves in the piston bosses.

- Inspect piston ring and replace if necessary - see 4.8.

- Oil needle cage in the small end.

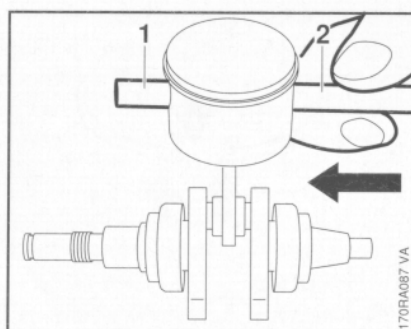

- Use the assembly drift (2) 1130 893 4700 to push the piston pin (1) out of the piston.

Note: If the piston pin is stuck, tap the end of the drift **lightly** with a hammer.
Important: Hold the piston steady during this process to ensure that no jolts are transmitted to the connecting rod.

- Remove the piston from the connecting rod.

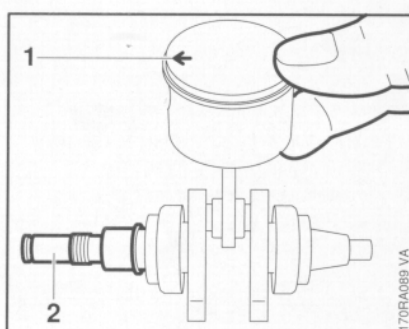

- To ease assembly, heat the piston slightly and push it over the connecting rod.

- Installed position of piston:

1 = Arrow
 2 = Long stub of crankshaft

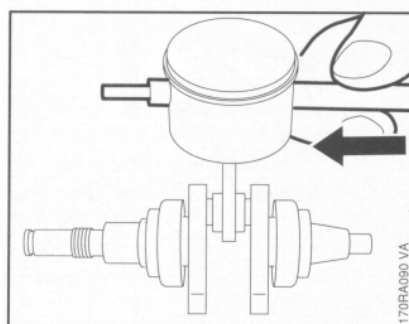

- Push the assembly drift, small diameter first, through the piston and small end (needle cage) and line up the piston.

4.8 Piston Ring

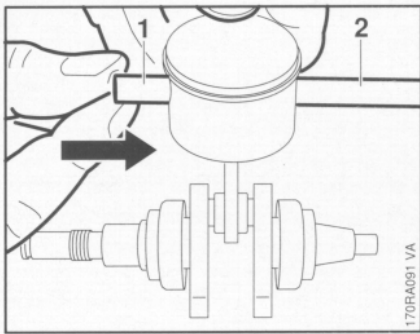

- Fit the piston pin (1) on the assembly drift (2) and slide it into the piston (the pin slides home easily if the piston is warm).

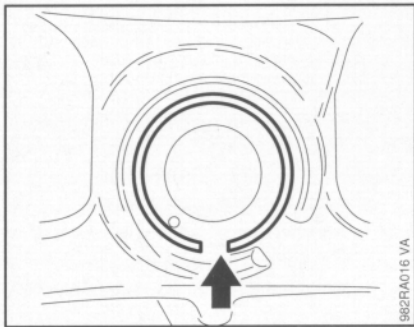

- Fit the hookless snap rings in the grooves.

Note: The ring gap must be on the piston's vertical axis (point either up or down).

- Install the piston - see 4.6.

- Pull the piston out of the cylinder - see 4.6.
- Remove ring from piston.

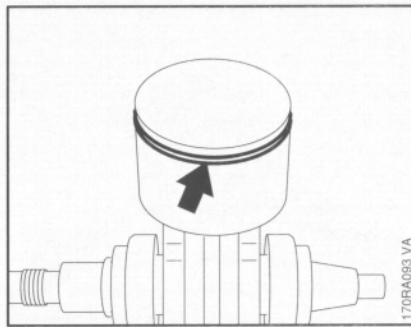

- Use a piece of old piston ring to scrape the groove clean.

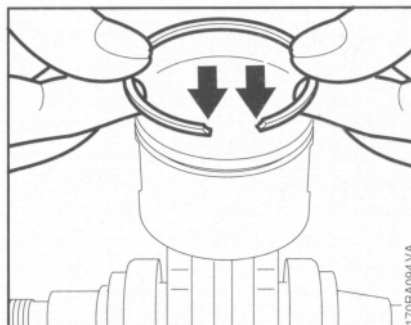

- Install the new piston ring in the groove so that the radii face upward to piston head.

- Install the piston - see 4.6.

4.9 Crankshaft

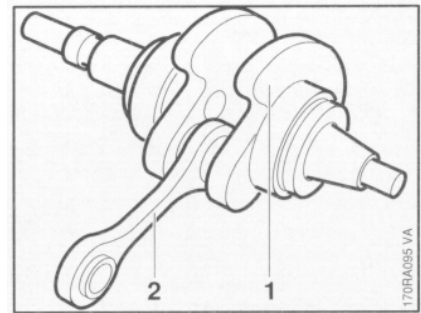

- Remove the piston - see 4.7.
- The crankshaft (1), connecting rod (2) and needle bearing are inseparable. This means the crankshaft must always be replaced as a complete unit.
- When fitting a replacement crankshaft, always install new oil seals and ball bearings.

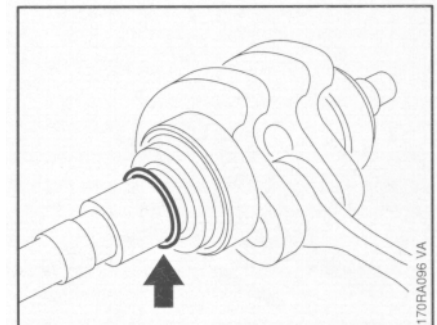

- Remove the retaining ring.

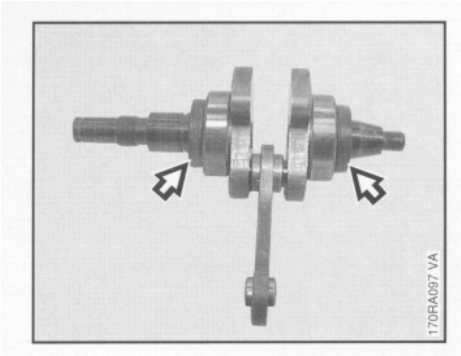

Note: If the engine pan has been removed from the cylinder for a repair, oil seals 9639 003 1585 (with rigid housing) may be installed.

- Pull off both oil seals.

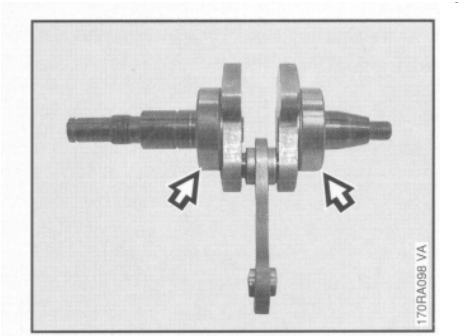

- Pull off both ball bearings.

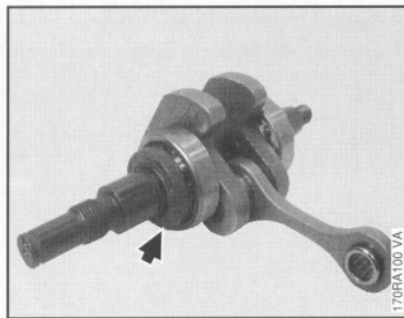

- Lubricate sealing lips of oil seals with grease - see 11.2.
- Slide oil seals over the crankshaft stubs so that their open sides are facing the ball bearings.
- Install new retaining ring in crankshaft groove.
- Install the piston - see 4.7.

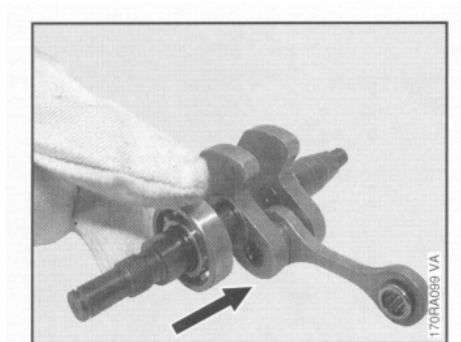

- Heat ball bearing to approx. 50°C (120°F) and push it on to the crankshaft stub as far as stop.

5. IGNITION SYSTEM 5.1 Spark Plug Boot

Warning! Exercise extreme caution when carrying out maintenance and repair work on the ignition system. The high voltages which occur can cause serious or even fatal accidents!

Troubleshooting on the ignition system should always begin at the spark plug. See "General Servicing, Troubleshooting" handbook.

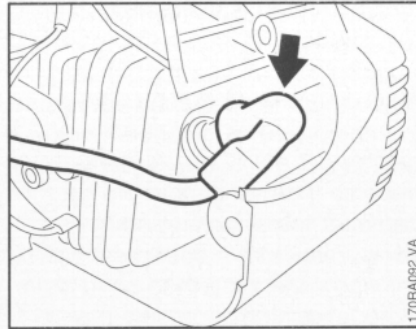

- Remove the fan housing
- see 6.2.

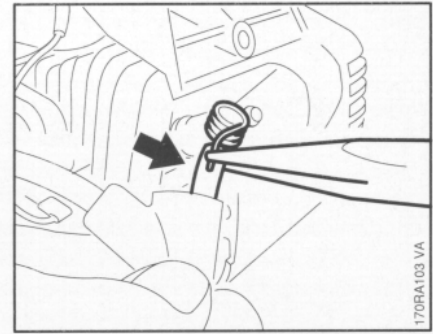

- Pull boot off the spark plug.

- Pinch the hook of the leg spring into the center of the lead, i.e. about 5 mm (0.2") from the end of the lead.

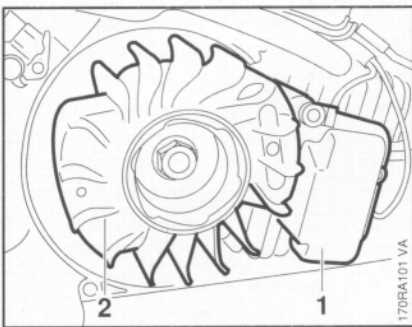

Note: The electronic (breakerless) ignition system basically consists of an ignition module (1) and flywheel (2).

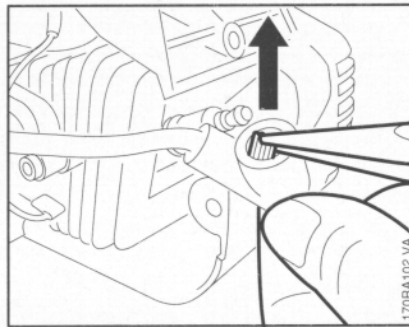

- Use pliers to grip the leg spring and pull it out of the spark plug boot.

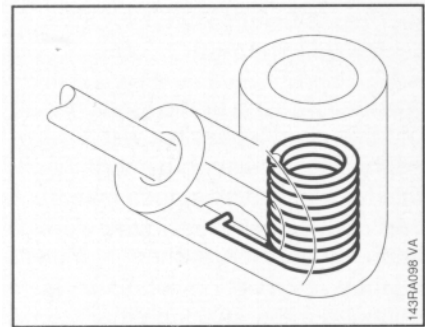

- Pull the lead back into the boot so that the leg spring locates properly inside it (as shown).

- Unhook the leg spring from the ignition lead.
- Pull spark plug boot off the ignition lead.
- Coat end of the ignition lead (about 20 mm/3/4") with oil.
- Fit spark plug boot over the ignition lead.
- Use pliers to grip the end of the ignition lead inside the spark plug boot and pull it out.

Important: If spark plug has a separate terminal nut, make sure that it is properly tightened down.

- Fit boot on spark plug.
- Fit the fan housing - see 6.2.