

Product: Nikon FA Digital Camera Service Repair Workshop Manual
Full Download: <https://www.arepairmanual.com/downloads/nikon-fa-digital-camera-service-repair-workshop-manual/>

FAA160AA

Nikon FA

ニコン FA

REPAIR MANUAL

修理指針



NIPPON KOGAKU K.K.

Sample of manual. Download All 245 pages at [Tokyo, Japan](https://www.arepairmanual.com/downloads/nikon-fa-digital-camera-service-repair-workshop-manual/)

<https://www.arepairmanual.com/downloads/nikon-fa-digital-camera-service-repair-workshop-manual/>

Product: Nikon FA Digital Camera Service Repair Workshop Manual
 Full Download: <https://www.arepairmanual.com/downloads/nikon-fa-digital-camera-service-repair-workshop-manual/>

SPECIFICATIONS & MECHANISM

Contents	Page
[1] SPECIFICATIONS	M1
[2] MECHANISM OUTLINE	
Mirror raise mechanism	M7
Mirror down mechanism	M9
Viewfinder display	M11

1. SPECIFICATIONS

Type of camera: Electronically controlled 35mm single-lens reflex

Usable film: 35mm film

Picture format: 24mm x 36mm

Standard lenses: AI-S Nikkor 50mm F1.2, 50mm F1.4, 50mm F1.8

Lens mount: Nikon bayonet mount

Maximum aperture index: Automatic with AI-S and AI Nikkor lenses

Shutter: Electromagnetically controlled vertical-travel, metal focal plane shutter with titanium curtains

Shutter speeds: Stepless speeds from 1/4000 to 1 sec. in P and A auto-exposure modes; 13 speeds from 1/4000 to 1 sec. on S and M; mechanically controlled, 1/250 sec. at M 250 setting and long exposure at B setting available

Exposure control: Three exposure modes: P (programmed), S (shutter-priority) and A (aperture-priority); M (manual) exposure mode selected via Mode changeover knob

P mode: With minimum aperture setting of the lens, the FA automatically selects the optimum combination of shutter speed and lens aperture settings for correct exposure by the prearranged program of its microcomputer

Also, the FA's microcomputer activates the High-Speed program automatically via Focal length (Fmm) signal when Nikkor or Nikon Series E lenses of 135mm * or longer are used

* High-Speed program operable lenses are AI-S Nikkor, Nikon Series E lenses and new teleconverters for AI-S type

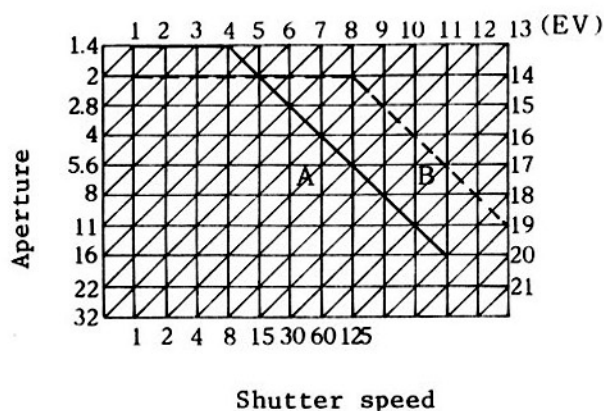

ASA/ISO 100

A: AI-S Nikkor 50mm F1.4 lens in use

B: AI-S Nikkor 135mm F2 lens in use

S mode: With minimum aperture setting of the lens, when a shutter speed is set, the FA automatically picks the matching lens aperture steplessly for correct exposure.

A mode: When a aperture of the lens is set, the FA automatically picks the matching stepless shutter speed for correct exposure.

M mode: Both aperture and shutter speed are set manually.

Viewfinder: Fixed eyelevel pentaprism type

Frame coverage: Approx. 93%

Finder magnification: Approx. 0.80X with 50mm lens set at infinity

Finder diopter: -1 ± 0.5 dpt.

Focusing screen: Interchangeable matte/fresnel focusing screen with central split-image rangefinder spot and microprism collar (Nikon Type K2) as standard; two other types of screens available optionally (Type B2 and E2)

How to change focusing screens: By pulling the focusing screen, release latch at the top front of the mirror box. A special tweezers is provided for screens change.

View finder information

a: Ready-light LED

b: LCD panel; 7-segments, 4-digit

c: ADR aperture f-number in use

d: Shutter speed in set

e: Exposure compensation mark

LED lights up which exposure compensation in use

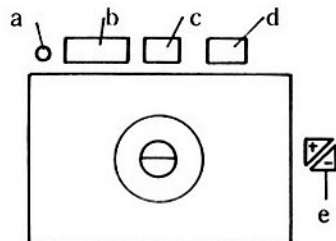

Film-advance lever: Single stroke; 165° full angle MD switch remains off in stand-off position. Release button is locked in rest position. Depressing of shutter button is prevented during film-advancing.

Exposure meter: Instant stop-down measurement for shutter control except on M mode Meter incorporated with two SPDs for Automatic Multi-pattern Metering (AMP)

Exposure meterings for Nikkor and Nikon Series E lenses

○: operable

X: inoperable

Mode	Type of lens	A M P	Centerweighted metering
P, S, A with stop-down switch off	AI-S, AI and series E	○	○
	Modified AI	×	○
	AI-S, AI and series E with teleconverter for AI-S type	○	○
	Modified AI with teleconverter for AI-S type	×	○
	AI-S, AI, modified AI and series E with teleconverter for AI type	×	○
M	All types	×	○
All modes with stop-down switch on	All types	×	○

Automatic Multi-Pattern Metering (AMP)

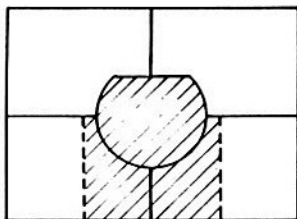

On P, S and A modes, AMP system divides the scene inside the frame into five segments and reads the brightness of each individual segment as shown in the figure. In accordance with the data of these segments, correct exposure is calculated to give optimum exposure automatically. Center of the frame surrounded by broken lines is divided into 4 segments vertically and horizontally.

Metering range: LV1 - LV20 at ASA/ISO 100 with F1.4 lens

Film speed range: ASA/ISO 12 - 4000

Exposure compensation: +2 - -2EV

+1 - -1EV at ASA/ISO 12 and 4000.

Exposure compensation mark inside the viewfinder lights up during in operation.

Out of metering range warning: P, S and A modes

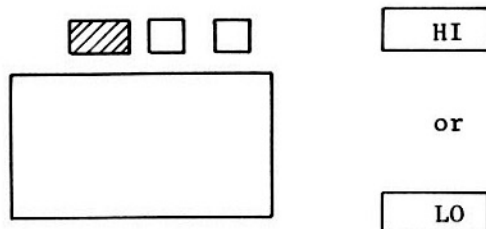

Over/under exposure warning: M mode

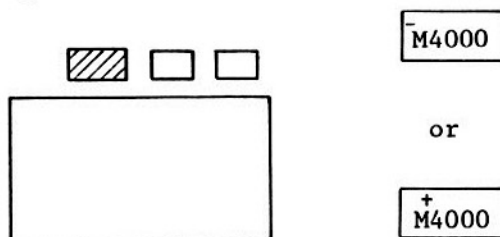

Warning if aperture is not set at minimum: P mode

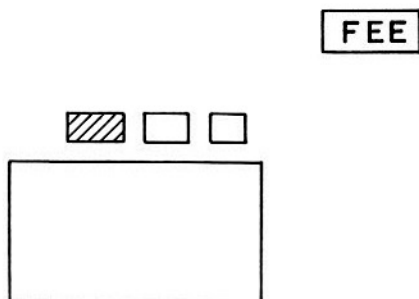

If the f/stop is not set at f/11 or larger f/number, FEE is indicated.

FEE is also indicated on S mode when correct exposure is not obtained at the aperture setting other than the minimum aperture.

Battery consumption: Metering: Approx. 9.4mA
 Shutter releasing: Approx. 17mA
 Exposure compensation LED lighting: Approx. 2mA

Accessory shoe: 4 contacts provided

1. Monitor contact
2. Sync contact
3. TTL flash auto-stop
signal contact
4. Ready-light contact

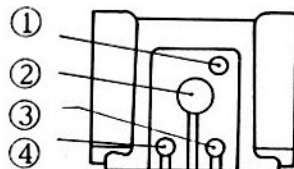

Flash synchronization: Sync with electronic flash unit at 1/250 sec. or lower.

On P, S and A modes (with the SB-15 or 16):
 flash sync automatically set to 1/250 sec.;
 LCD shows "250"

On M mode (with SB-15 or 16):

When shutter dial is set between 1/500 sec.
 and 1/4000 sec., flash sync automatically set
 to 1/250 sec. and LCD shows "M 250".

At 1 - 1/250 sec. settings, shutter speed is
 as set.

Ready-light lights up after flash output is
 charged on both P, S, A and M modes.

Self-timer: 8 - 14 sec. delayed exposure; mechanical type;
 cancellable after setting.

Frame counter: Additive type, self-resetting; until the frame
 counter reaches "1", shutter fires at 1/250 sec, LCD
 in the viewfinder displays "C 250" on P, S and A modes,
 and "MC 250" on M mode.

Multiple exposure: Possible via lever

Shutter release: At 1 - 1/4000 dial settings, depressing shutter
 release button halfway turns power switch on and
 further depressing turns magnetic release switch on and
 to release shutter.

At M 1/250 and B settings, shutter releases
 mechanically.

Power switch: Power switch is turned on when shutter release button
 is depressed halfway; it remains on for approx. 16 sec.
 after finger is lifted off the button.

By setting shutter dial to M 1/250 or B, power switch
 turns off.

Battery check: By confirming if power switch is on by depressing shutter release button halfway.

Battery voltage	Power switch
2.5V or more	Remains on for approx. 16 sec.
2.5V - 2.3V	Remains on momentaly
2.3V or less	Fails to turn LCD readout on Prohibits shutter release

Power source: Two 1.55V silver-oxide batteries, one 3V lithium battery or two alkaline-manganese batteries.

Battery power is supplied by the MD-15's power source when attaching the motor drive to the FA.

Flash synchronization

on M250/B release: Ready-light lights up when the speedlight is charged; TTL flash output control unavailable.

Depth-of-field preview: Via lever provided; when lever actuated, P and S modes changed into full-aperture center-weighted metering on A mode; A and M modes changed into stop-down center-weighted metering

Shutter dial lock: Locked at M250 and B settings; released by depressing the button

Eyepiece shutter: Closed by turning eyepiece shutter lever clockwise

Motor drive coupling: MD-11, MD-12, MD-15; by tripod/motor drive coupling socket; film-advance coupling angle: 135°

Handgrip: Detachable; must be detached when attaching motor drive

Camera back: Hinged; safety lock provided

Data back contacts: Provided for the data back MF-16

Demensions: 142.5mm (W) x 92mm (H) x 64.5mm (D)

Weight: Approx. 625g (without lens)

ミラーアップ Mirror raise mechanism

※各図はチャージ状態を
示している。

All figures show mech.
of charged condition.

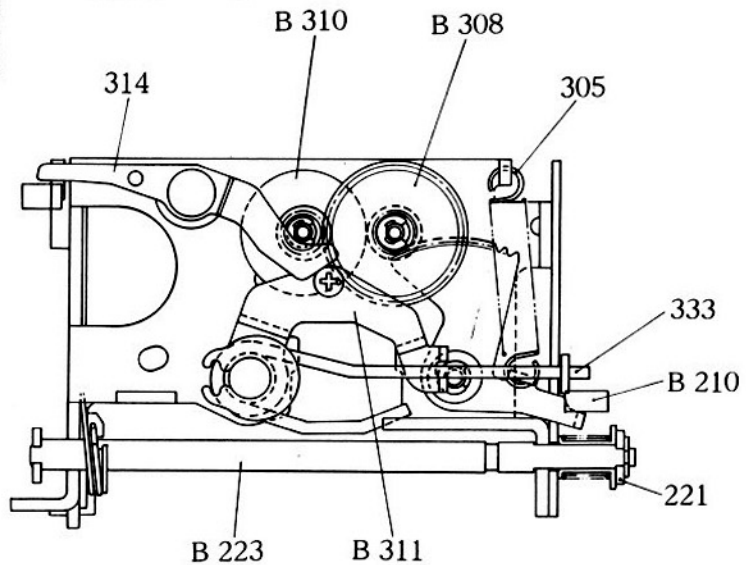
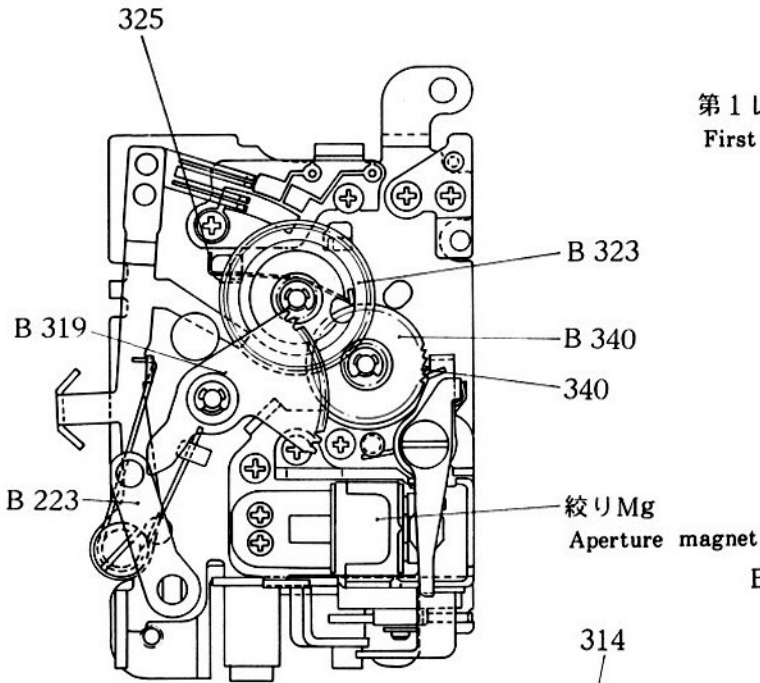
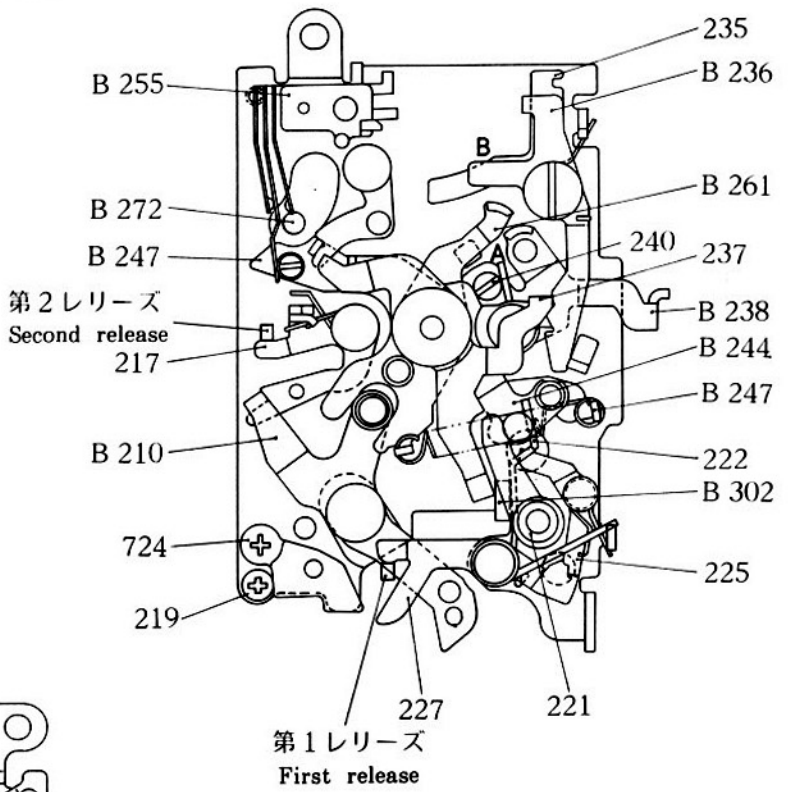

MIRROR RAISE MECHANISM

Broken-line enclosure indicates that the parts of mechanism are released in this sequence.

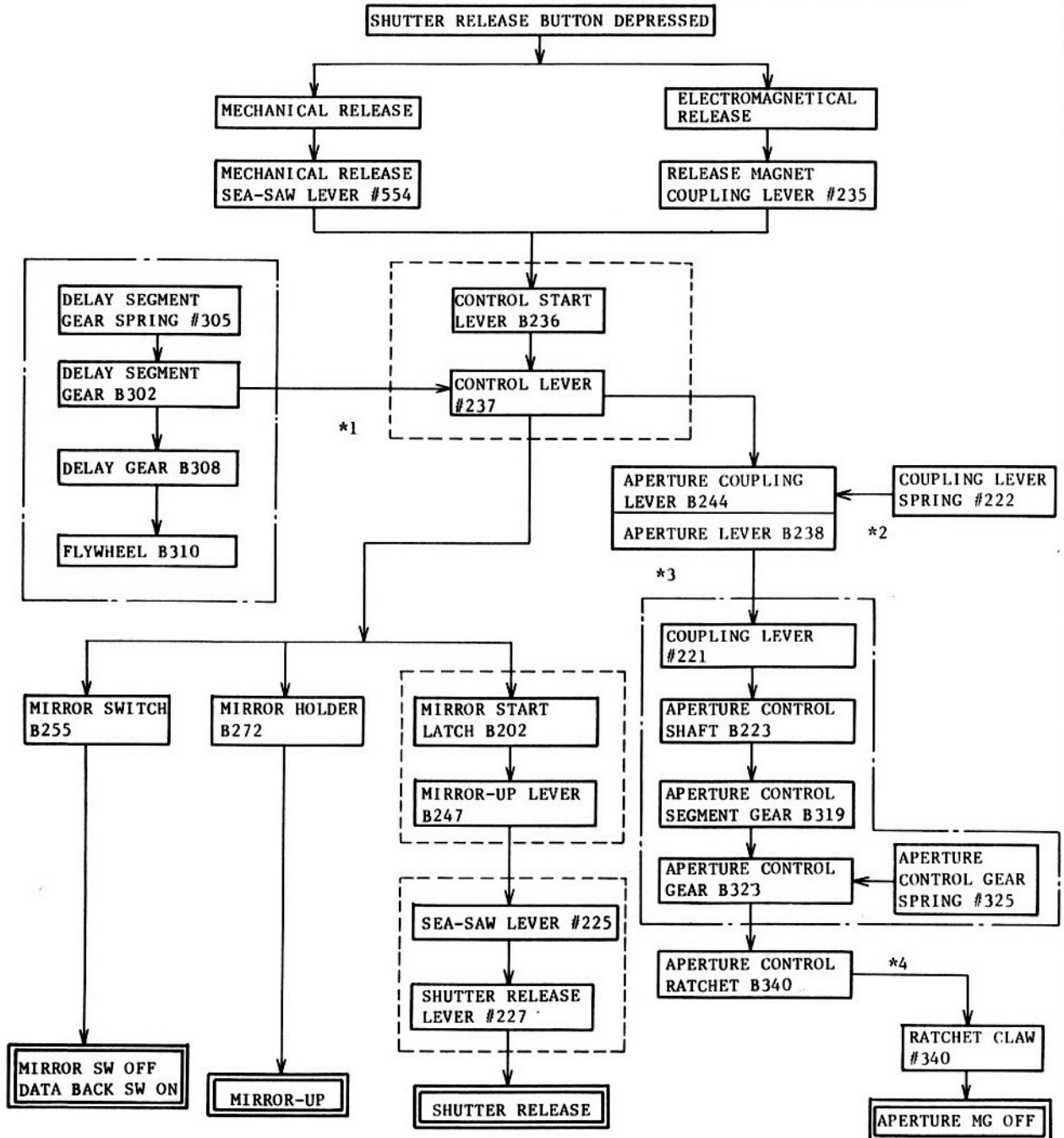

Control lever start

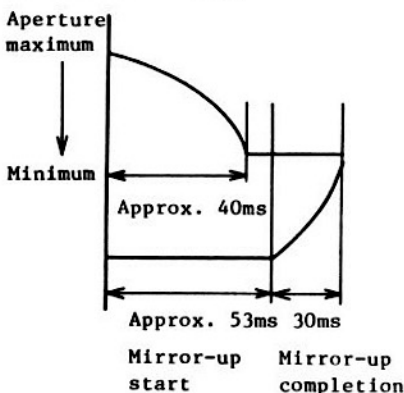

- *1: Flywheel B310 and Delay gear B308 delay action of Mirror up lever B247 for approx. 53ms.
- *2: Coupling lever spring #222 makes Aperture coupling lever B244 and Aperture lever B238 turn clockwise.
- *3: Coupling lever spring #222 and Delay gear B308 controls the time for approx. 40ms that Aperture lever B238 stops down the aperture from the max. opening to the min. opening.
- *4: On P and S modes, when Aperture magnet is turned off, the ratchet claw latches Ratchet #340 and Aperture coupling lever B244 to control Aperture lever B238.

ミラーダウン Mirror down mechanism

※各図はミラーアップ状態を示している。

All figure show mech. of released condition.

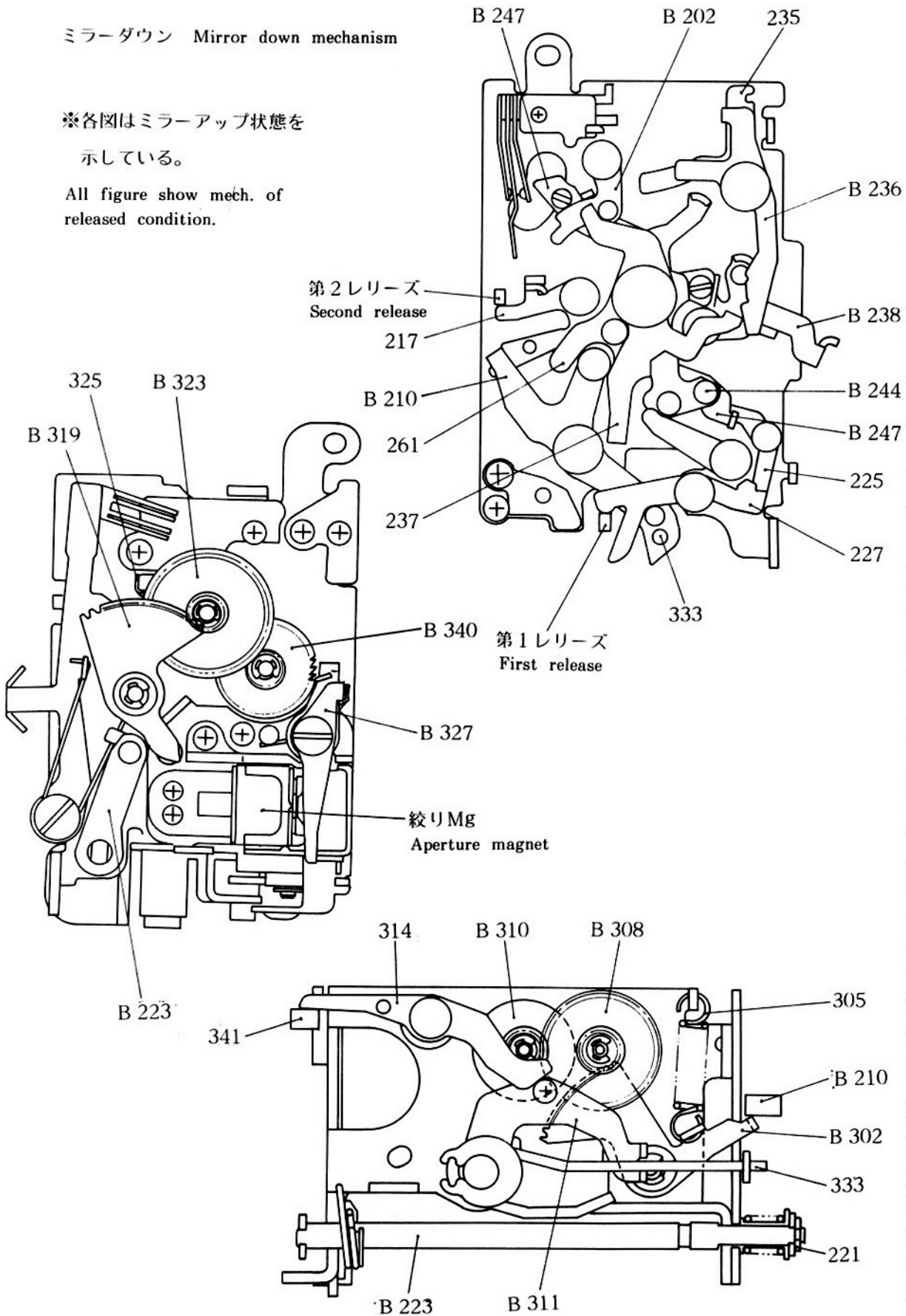

MIRROR DOWN MECHANISM

Broken-line enclosure indicates that the parts of mechanism are latched in this sequence.

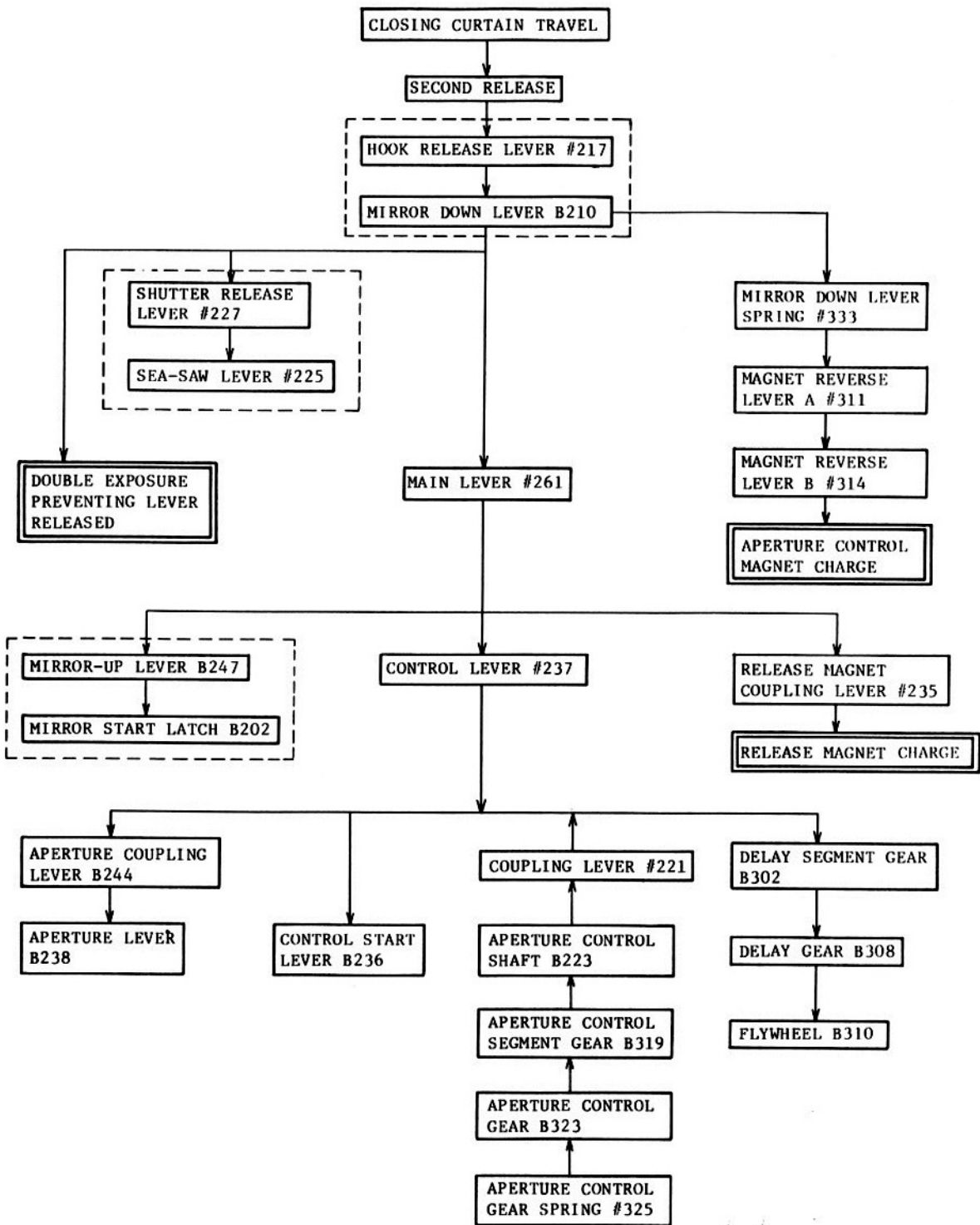

VIEWFINDER DISPLAY

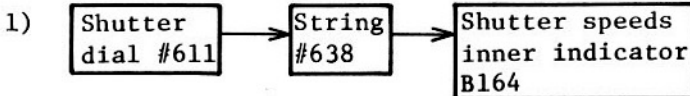
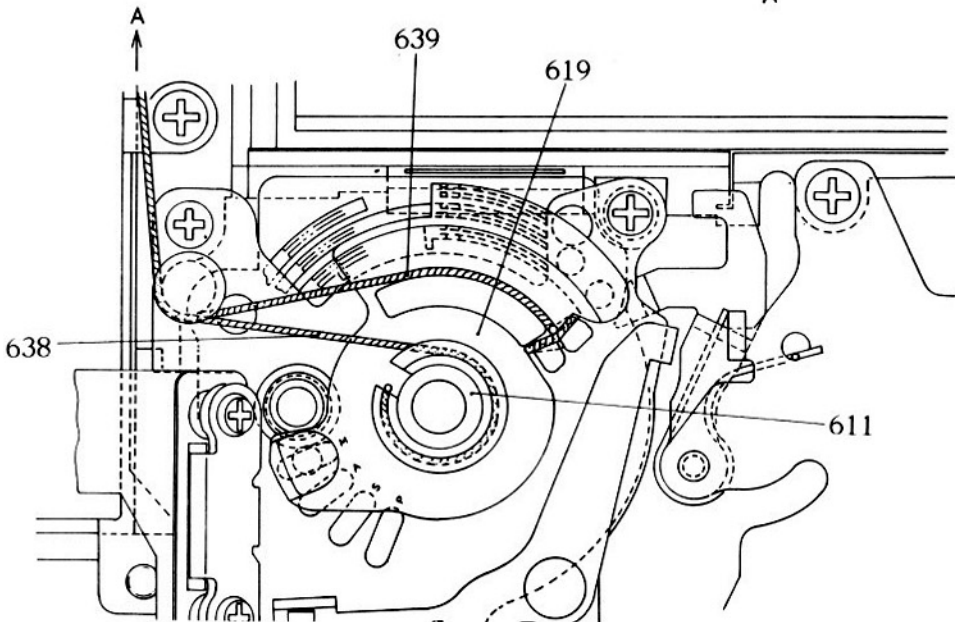
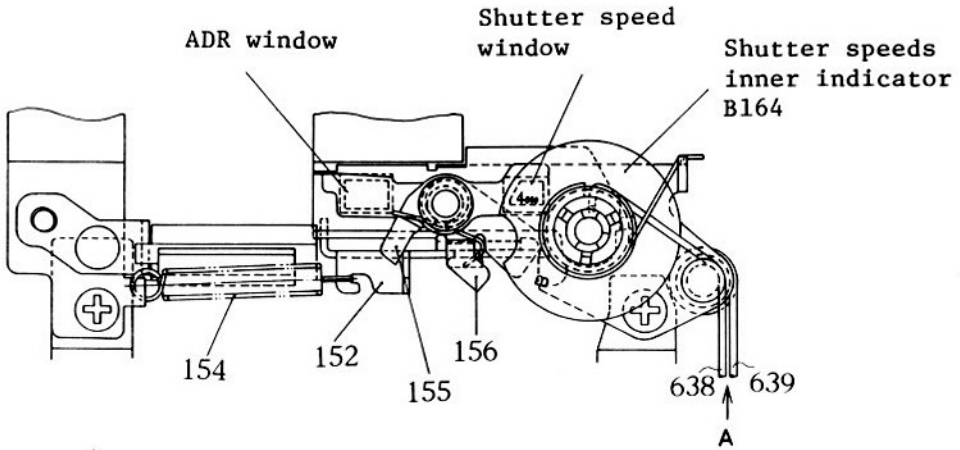
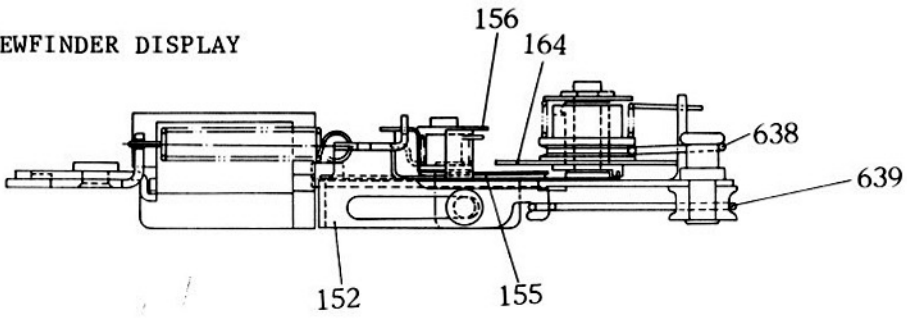

Turning shutter dial #611 makes shutter speeds inner indicator B164 rotate via String #638 to indicate the shutter speed in use.



By turning Mode changeover cam B619, the mask plates cover either ADR window or shutter speed window.

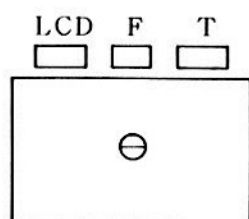

(ASA/ISO 100)
EV15 $\frac{1}{500}$ F = 8

Viewfinder display patterns changeable with the mode selection.

Mode	LCD	ADR	Shutter speed
P	500		
S	F8		500
A	500	8	
M	M500	8	

ASA/ISO 100, EV15

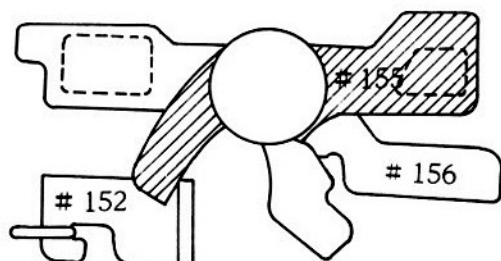

P mode

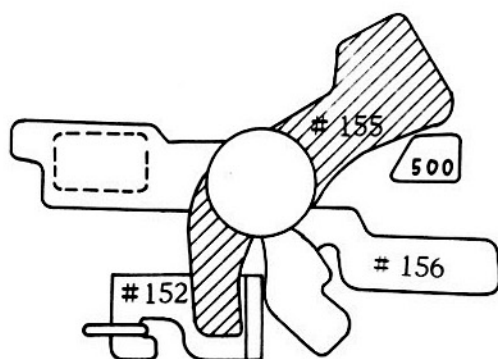

S mode

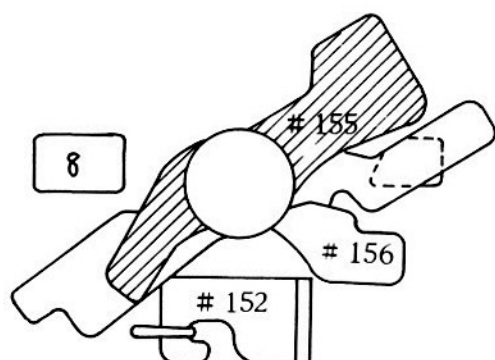

A mode

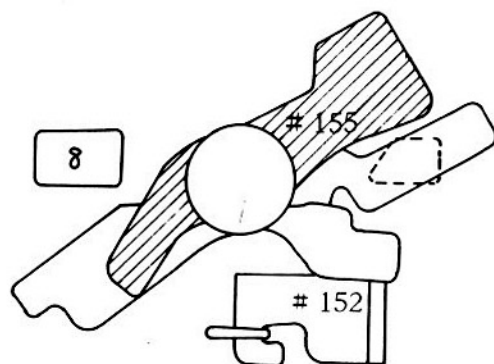

M mode

DISASSEMBLING & ASSEMBLING & ADJUSTMENTS & EXPLOSION DRAWINGS

Contents	Page
[1] DISASSEMBLING	
1. Disassembling outline	D1
2. Disassembling procedure	D2
[2] ASSEMBLING, ADJUSTMENTS AND EXPLOSION DRAWINGS	
1. Film-advance Shaft, Sprocket (Figure 1)	A1
2. Film-advance Mechanism Unit (Figure 2)	A2
3. Film-advance Lever Unit (Figure 3)	A3
4. Body, Shutter (Figure 4)	A5
5. Bottom Cover (Figure 5)	A7
6. Rewind Shaft (Figure 6)	A9
7. Mirror Mechanism (Figure 7)	A11
8. Mirror Mechanism (Figure 8)	A13
9. Front Plate 1 (Figure 9)	A15
10. Bayonet (Figure 10)	A17
11. Front Plate 2 (Figure 11)	A19
12. Front Plate 3 (Figure 12)	A21
13. Pentagonal Prism (Figure 13)	A25
14. FPC (Figure 14)	A27
15. Top Cover (Figure 15)	A34
15-1. Shutter Speed Accuracy Adjustments	A35
15-2. Switches/Gray Code Checking	A37
16. Camera Back Hinge (Figure 16)	A39
17. Camera Back (Figure 17)	A40

1. DISASSEMBLING OUTLINE

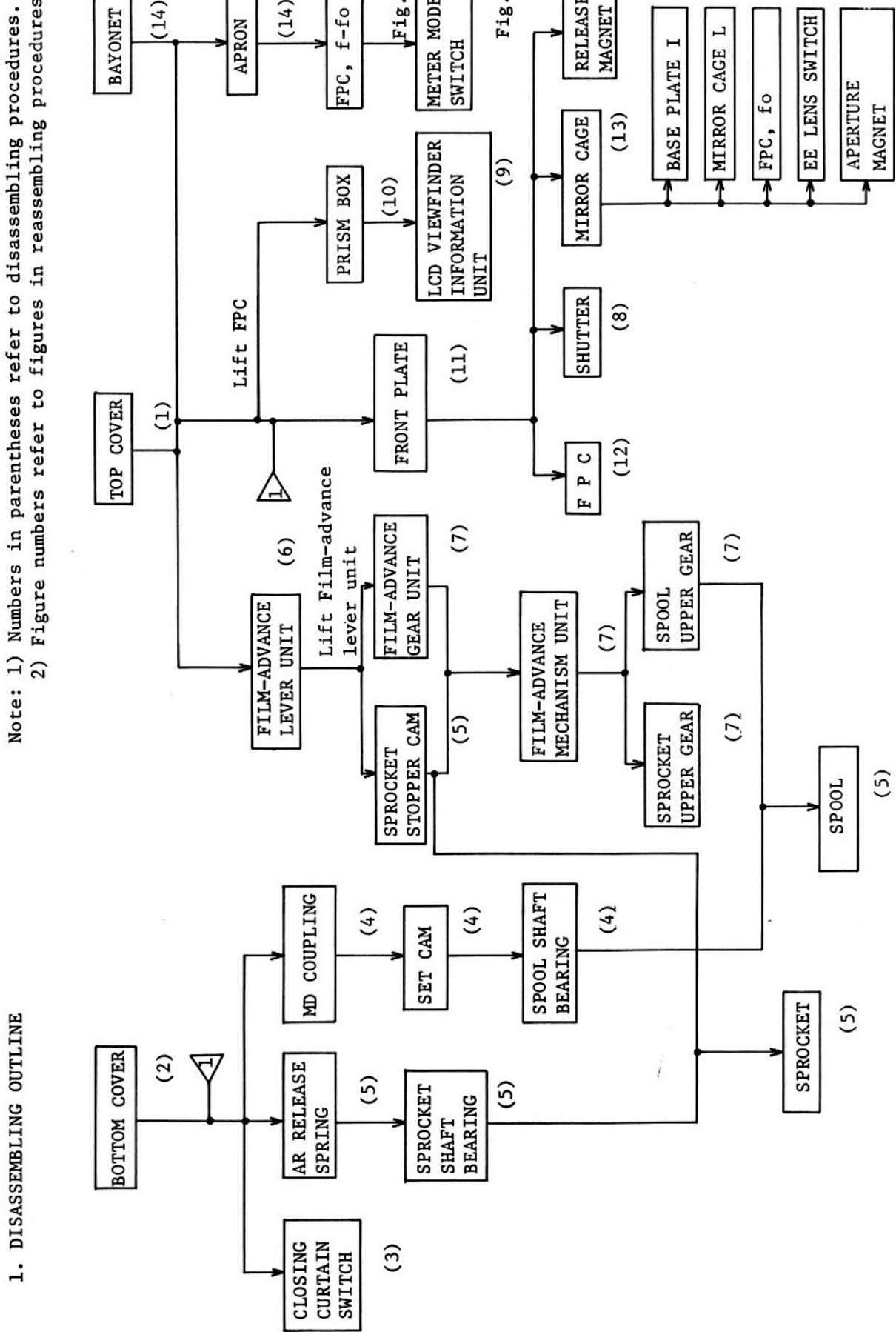

Note: 1) Numbers in parentheses refer to disassembling procedures.
 2) Figure numbers refer to figures in reassembling procedures.

2. DISASSEMBLING PROCEDURE

- Note: 1) Disassembling should be started after batteries are removed.
- 2) Figure numbers refer to figures in reassembling procedure.
- 3) Be sure to learn how the lead wires are arranged.

(1) Top cover

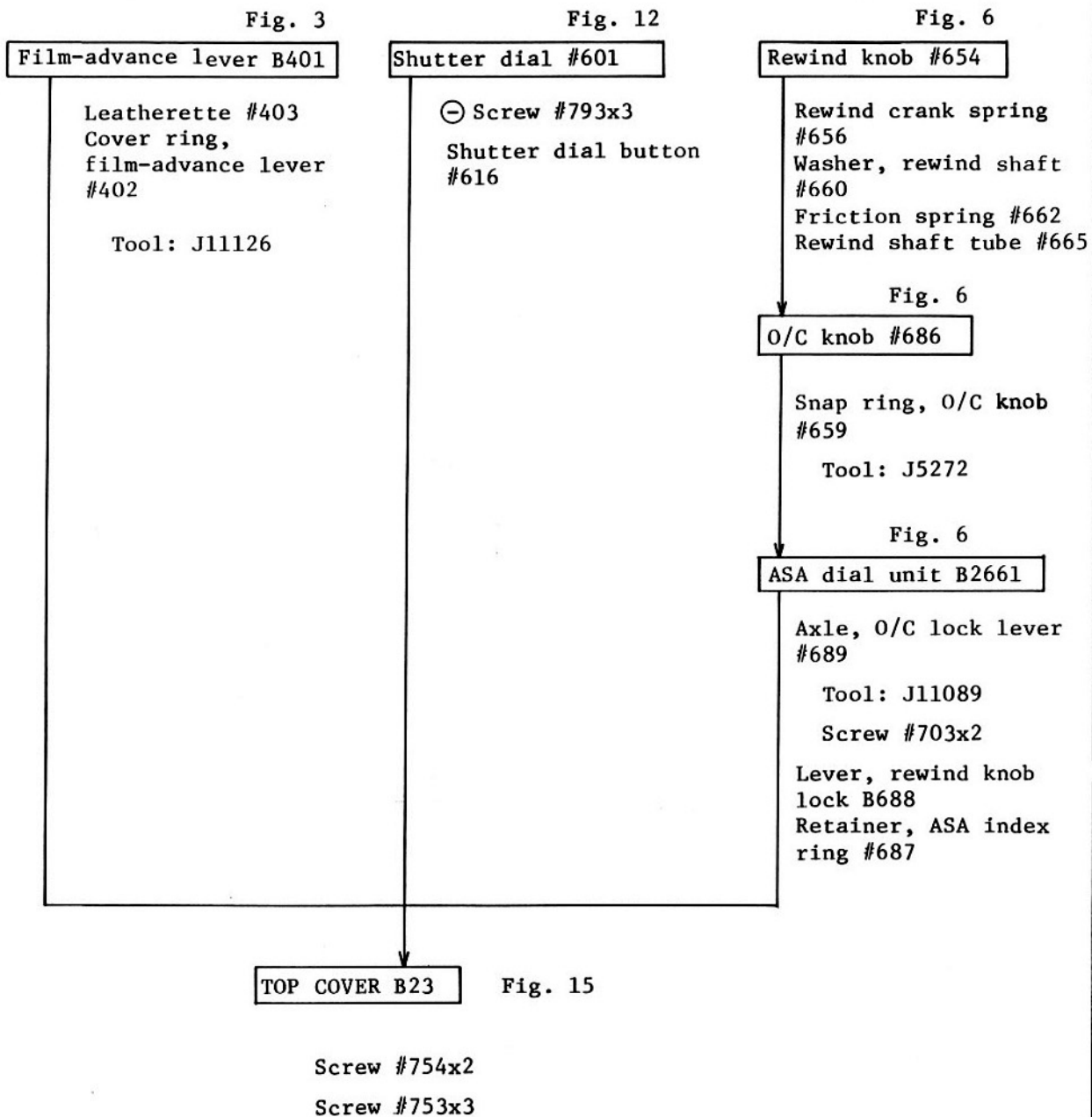

(2) Bottom cover

Battery chamber lid B137 Fig. 5

↓
Bottom cover B24 Fig. 5

Screw #751x3

(3) Closing curtain switch

Unsolder lead wires from
Closing curtain switch B549 Fig. 5

↓
Lead wires
#1078 (blue), #1070 (blue)
#1079 (brown), #1071 (brown)

↓
Closing curtain switch B549 Fig. 5

Screw #743

(4) Spool

(5) Sprocket

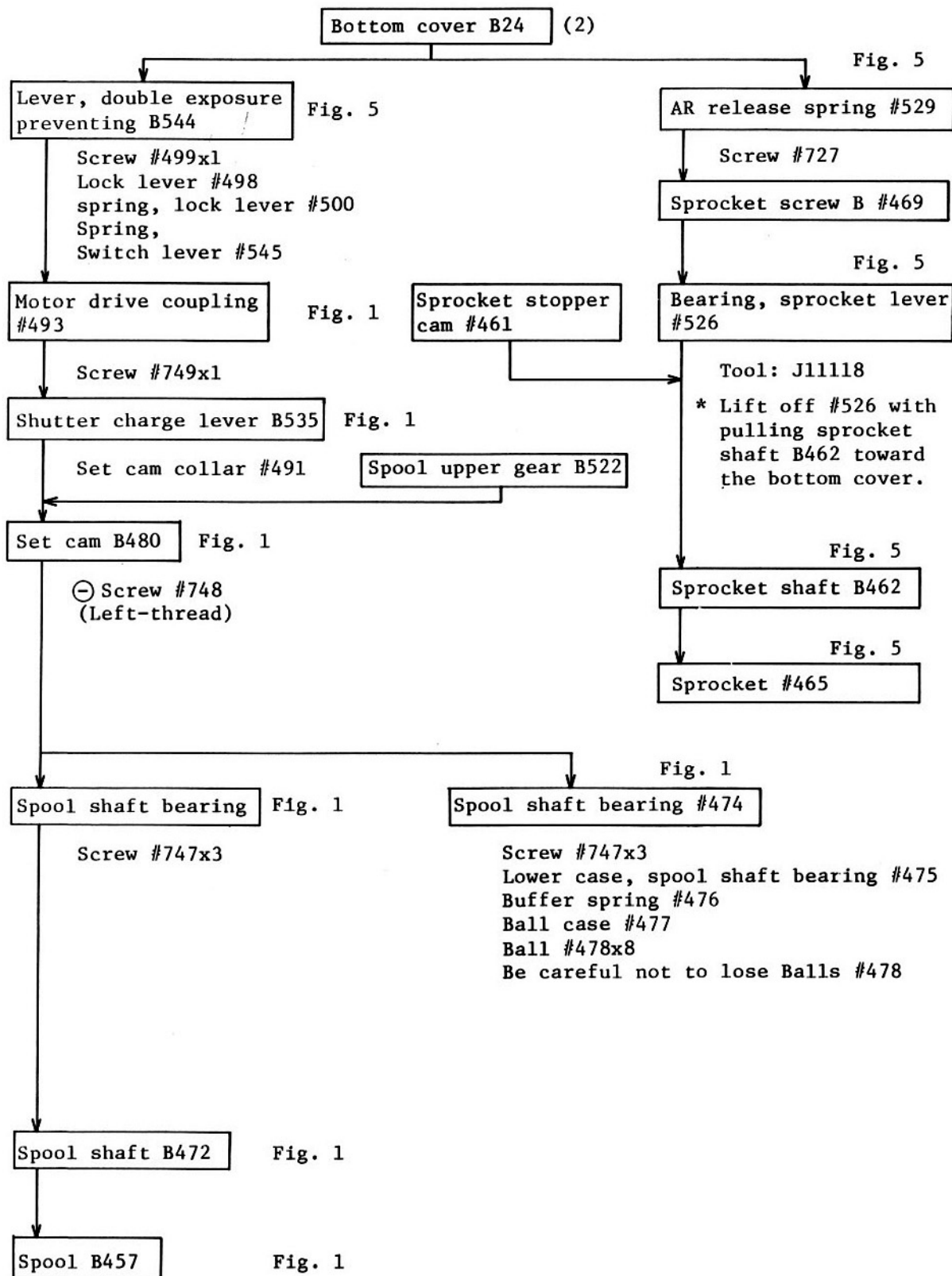

(6) Film-advance lever unit

(7) Film-advance mechanism unit

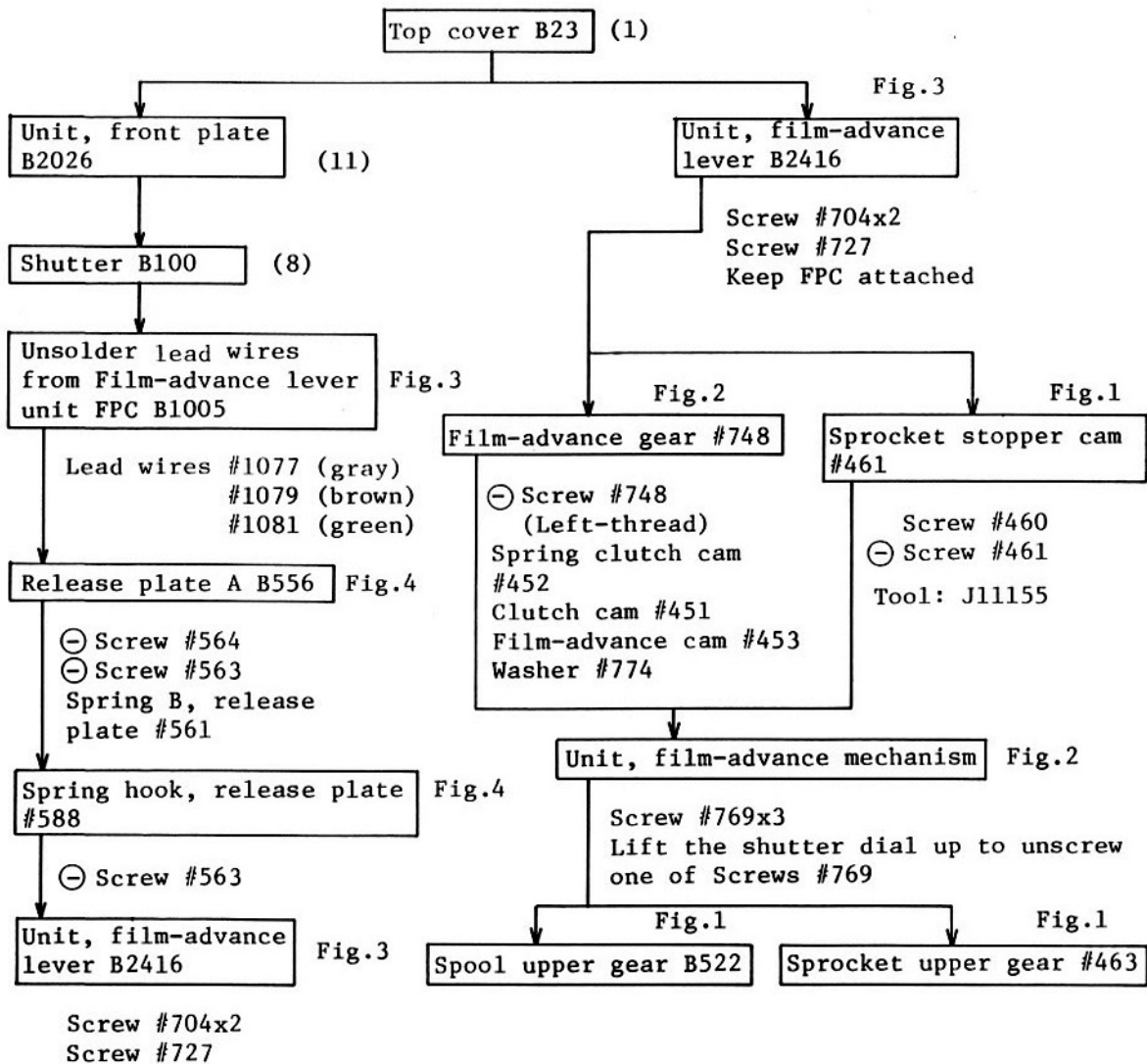

(8) Shutter

(9) Unit, LCD viewfinder information

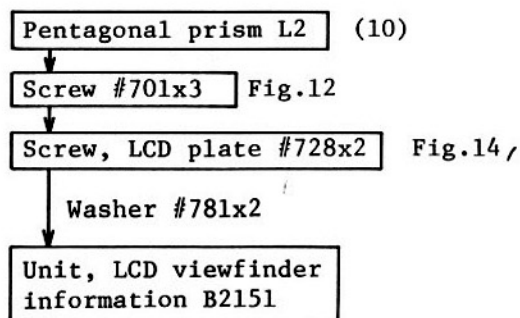
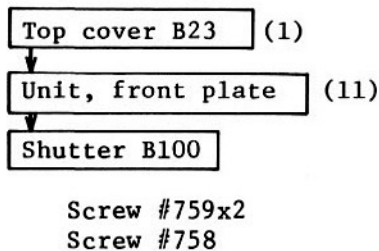

(10) Pentagonal prism

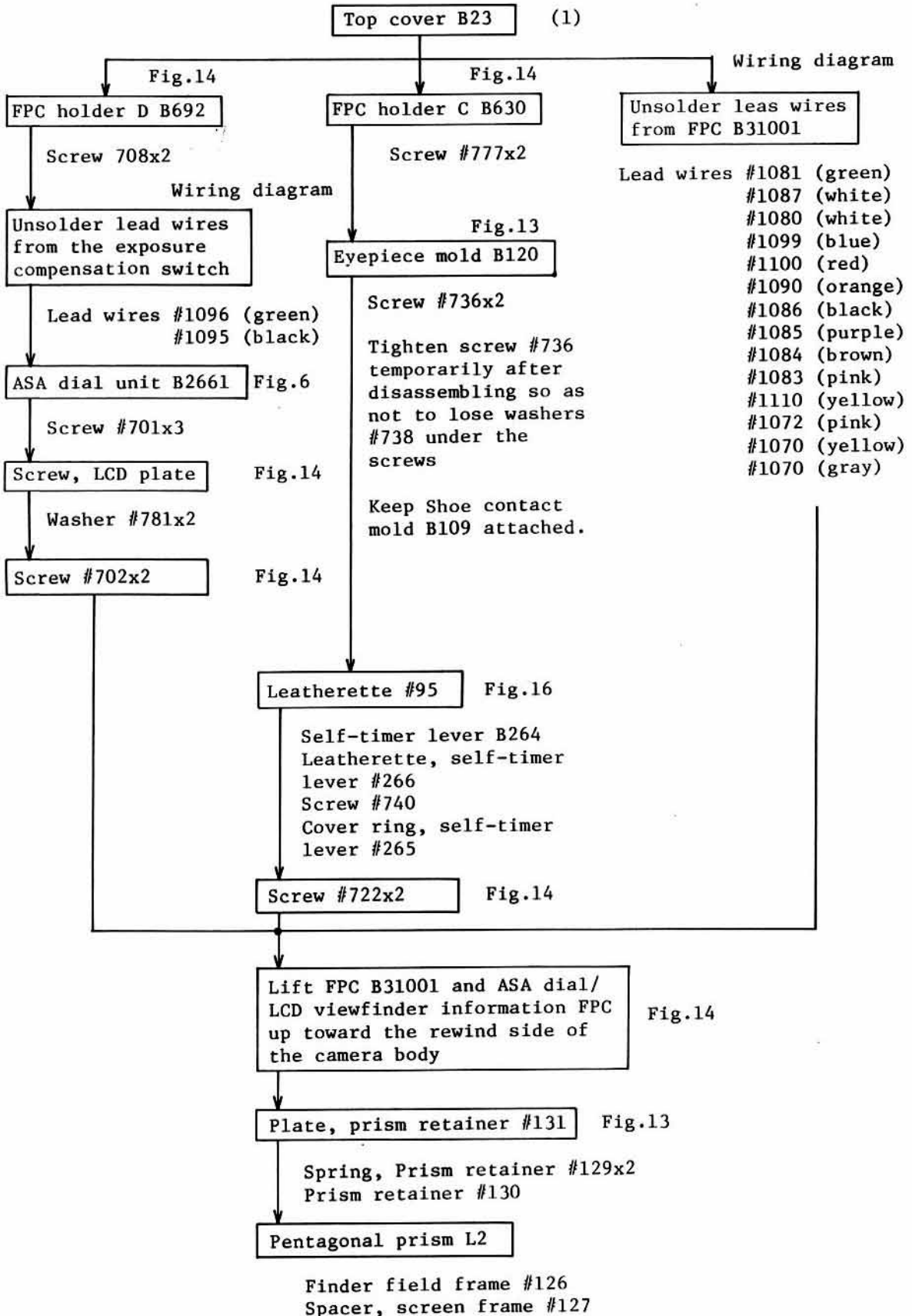

(11) Unit, front plate

FPC holder D B691 Fig.14

Screw #708x2

Unsolder leas wires from the exposure compensation switch Fig.6

Lead wires #1096 (green)
#1095 (black)

ASA dial unit B2661 Fig.6

Screw #701x3
One of screws #701 locates under the exposure compensation dial lock spring

Screw, ASA dial/LCD viewfinder information FPC B1002 Fig.14

Screw #702x2

FPC holder C B630 Fig.14

Acceptor, FPC holder C B628
Screw #777x2

Screw, Shutter dial Fig.12

Unscrew one of screws #701 located at the eyepiece side

Unsolder lead wires from FPC B31001 Wiring diagram

Leadwires #1080 (white)
#1081 (green)
#1072 (pink)
#1112 (white)

Unsolder lead wires from Shoe contact mold B109 Wiring doagram

Lead wires #1105 (orange)
#1082 (orange)
#1106 (black)



Screws, MD base plate Fig.14

Screw #704x2

Unsolder lead wires from the MD base plate Wiring diagram

Peel off Tape #46
Lead wires #1077 (gray), #1076 (yellow), #1075 (black), #1074 (red), #1073 (blue), #1072 (pink), #1071 (brown)

Self-timer lever B264 Fig.13

Leatherette, self-timer lever #266
Cover ring, self-timer lever #265
Screw #740

Leatherettes A #95 and B #96 Fig.16

Cover, variable resistors B27 Fig.13

Screw #701x3
Retainer, printed circuit #28

Unscrew screws from Front plate unit B2026 Fig.13

Screw #755x5
Screw #743
Screw #756x2

Remove Front plate unit B2026

Peel off the tape under the shutter dial.
Separate shutter control FPC #99 from the cutout of shutter dial when removing.

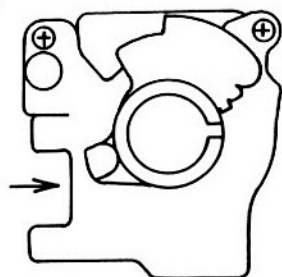

(12) F P C

Mount a tool lens to facilitate holding of camera disassembled.
Be careful not to damage the MD contact.

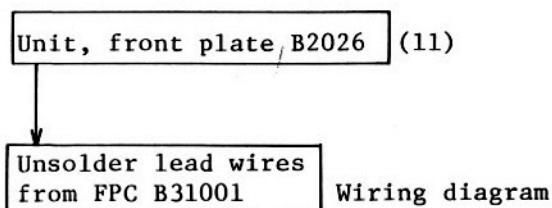

- Lead wires
 #1110 (yellow), #1083 (pink)
 #1070 (gray) and (yellow)
 #1087 (white), (red) and (blue)
 #1086 (black), #1085 (purple)
 #1084 (brown), #1099 (blue)
 #1100 (red), #1098 (gray)
 #1097 (purple), #1090 (orange)
 #1091 (green), #1093 (pink)
 #1094 (yellow),
 #1103 (green), #1104 (brown)
 #1108 (white), #1107 (white)

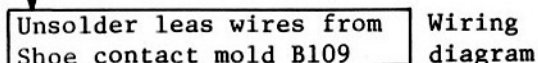

- Lead wire #1092 (green)
 #1115 (black)
 #1106 (black)

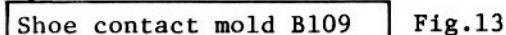

Screw #765

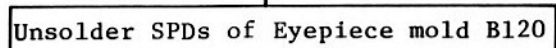

Remove antimoisture coating of silicon.

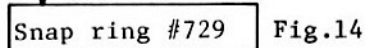

Washer #781x2

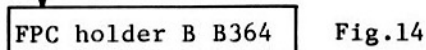

Screw #710x2

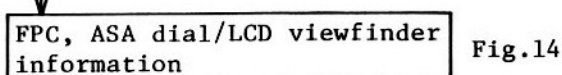

Peel off the tape on the memory condenser

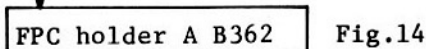

Screw #711x2

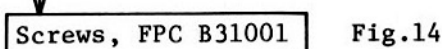

Screw #779x2

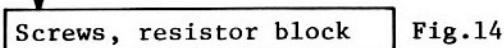

Screw #722x2

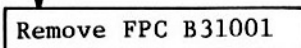

Be careful not to break the FPC when removing.

(13) Mirror box

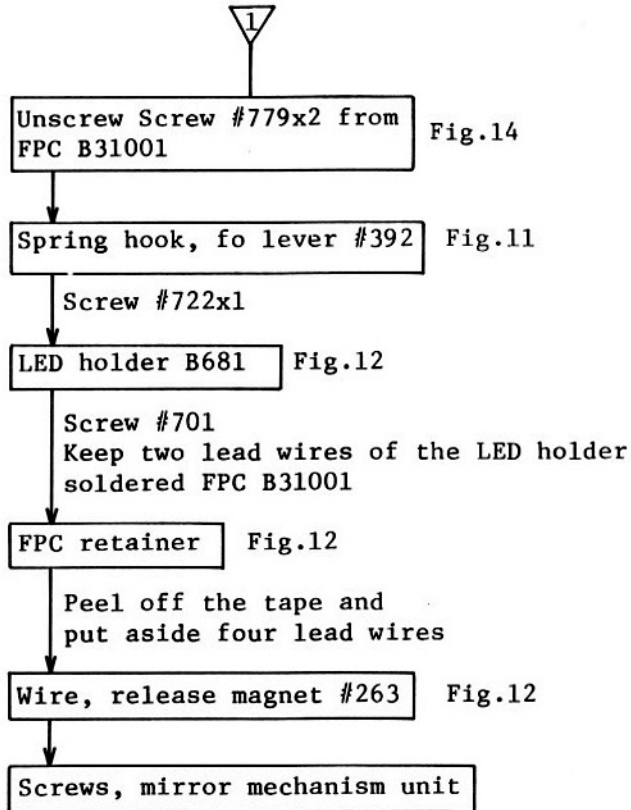
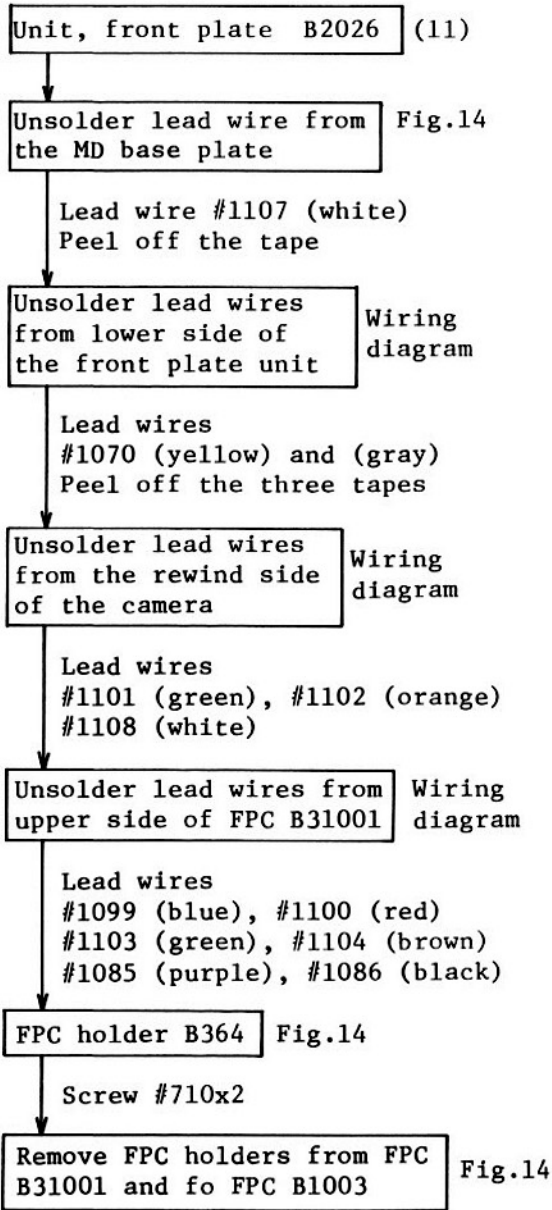

Screws
 #713, #286
 #358 and #260
 Lift FPC B31001 up to unscrew these screws.
 Be careful not to bend Mirror light baffle plate #283.



(14) Bayonet

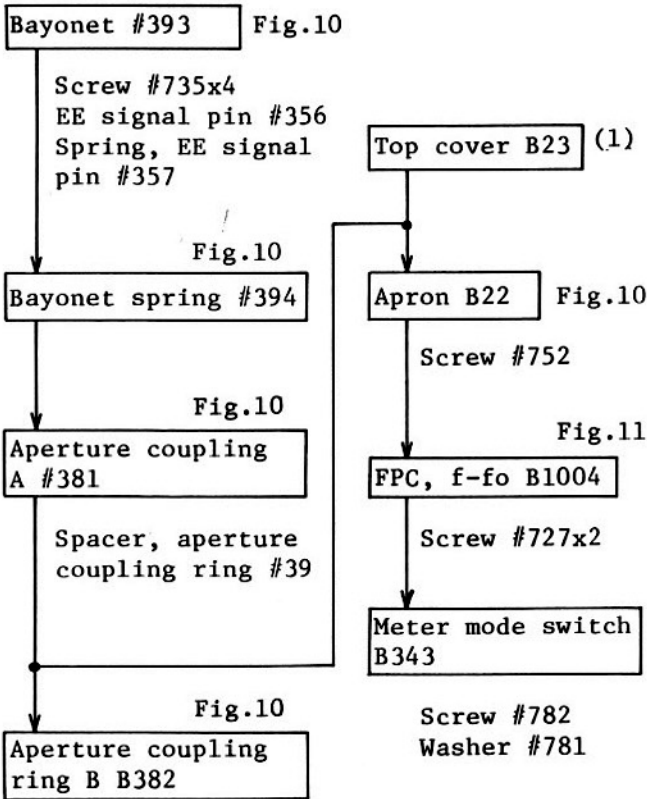

Remove spring #379

(15) Base plate I, Mirror cage L

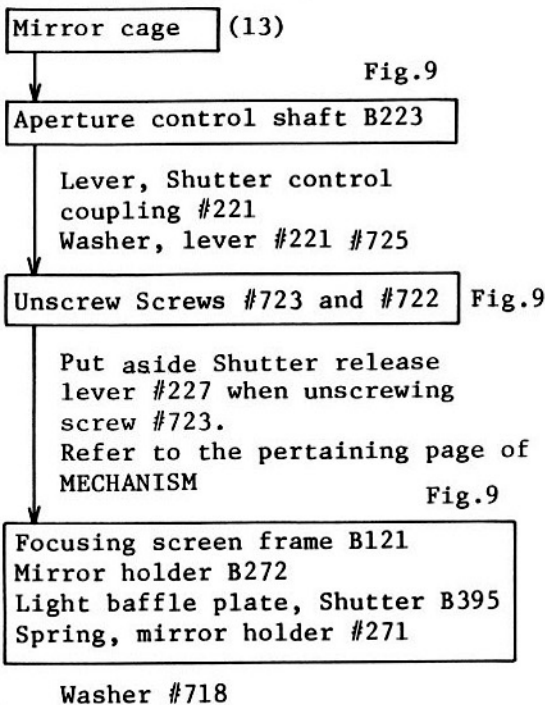

1. 巻上軸 スプロケット軸部 FILM-ADVANCE SHAFT, SPROCKET

外周

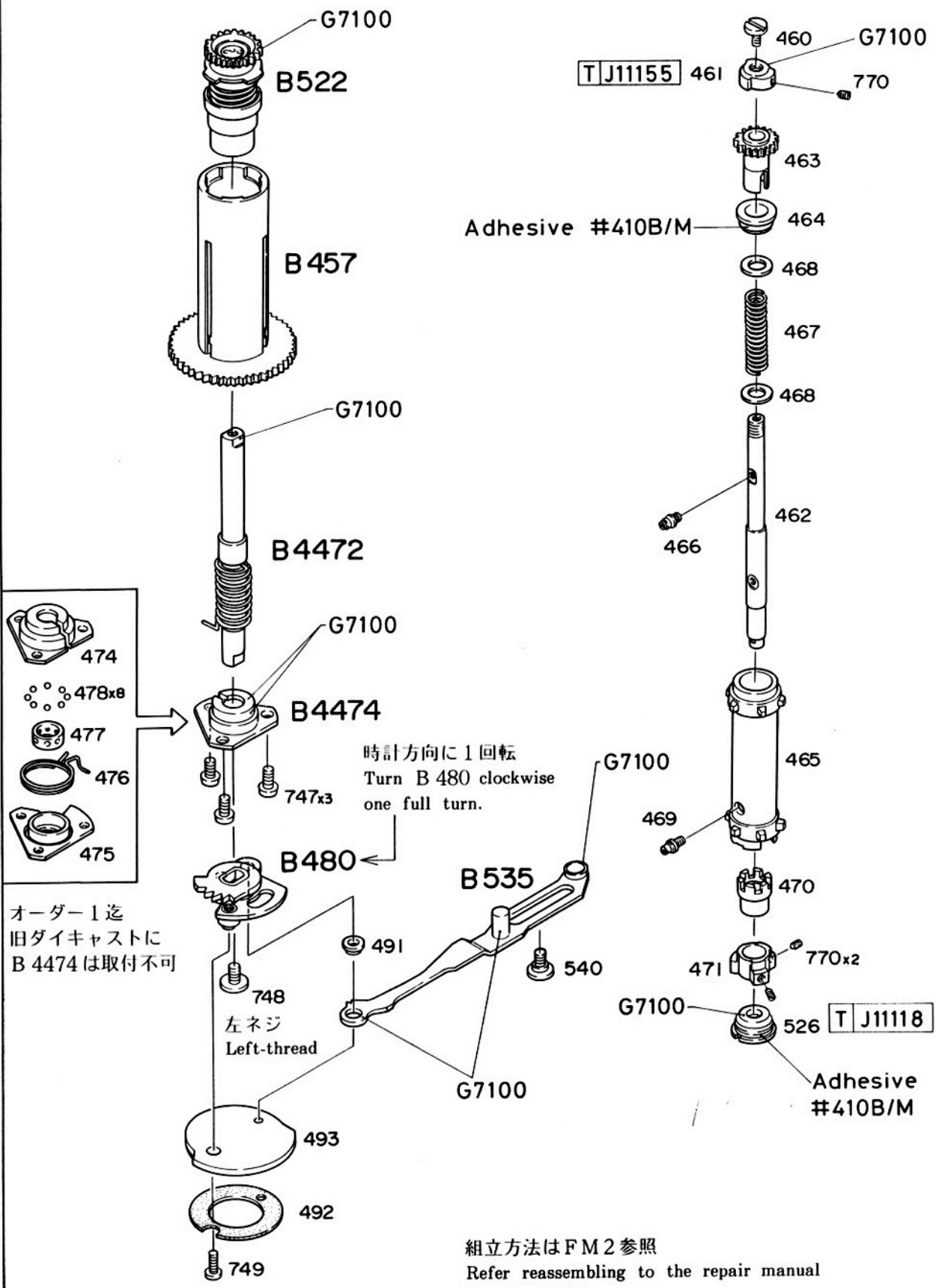

オーダー1迄
旧ダイキャストに
B 4474 は取付不可

時計方向に1回転
Turn B 480 clockwise
one full turn.

左ネジ
Left-thread

組立方法はFM2参照
Refer reassembling to the repair manual
for the FM2

Fig. 1

組立方法はFM2参照
Refer reassembling to the repair manual for the FM2

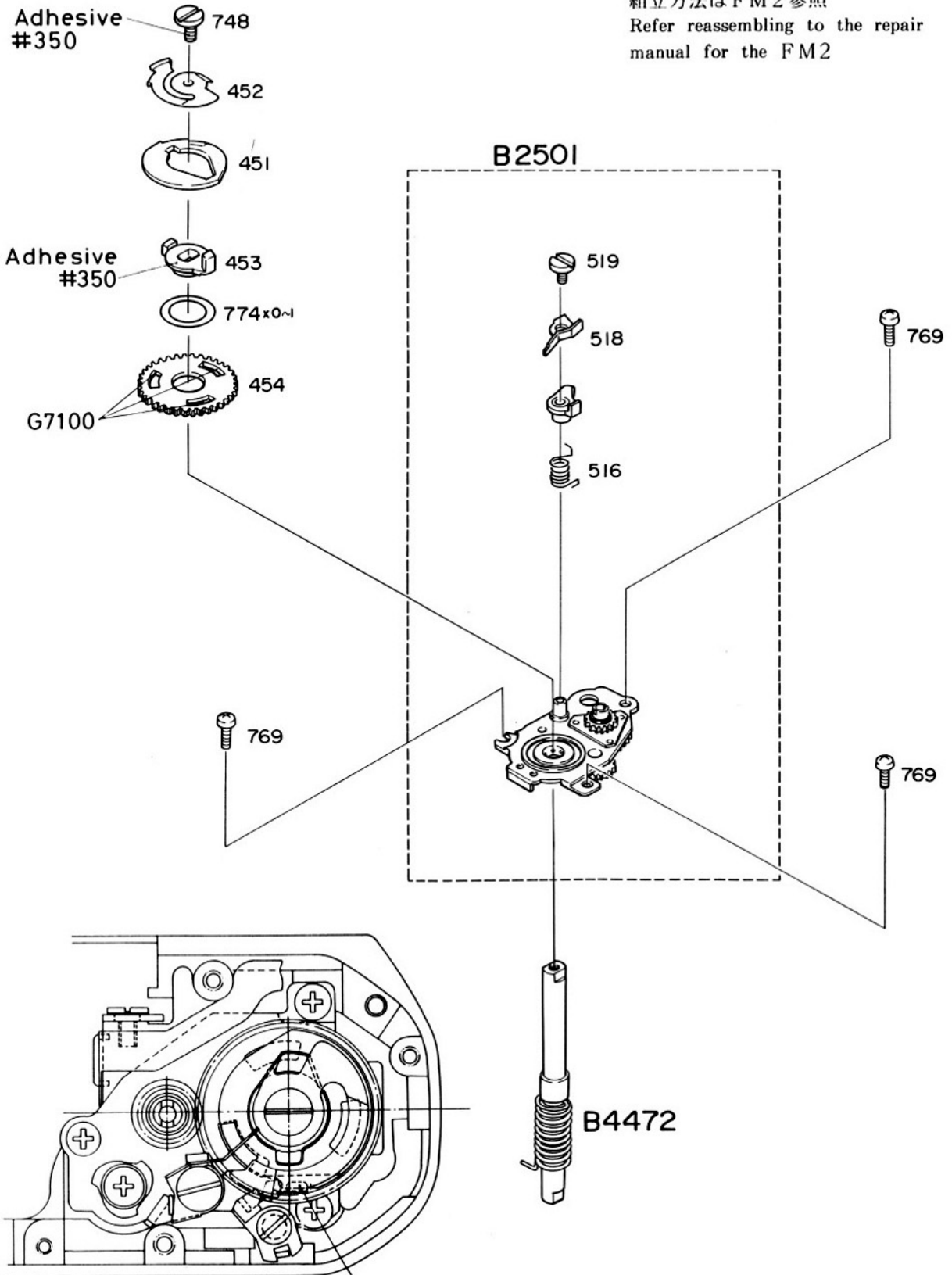

451 をはさみ込む
451 secured by 452

Fig. 2

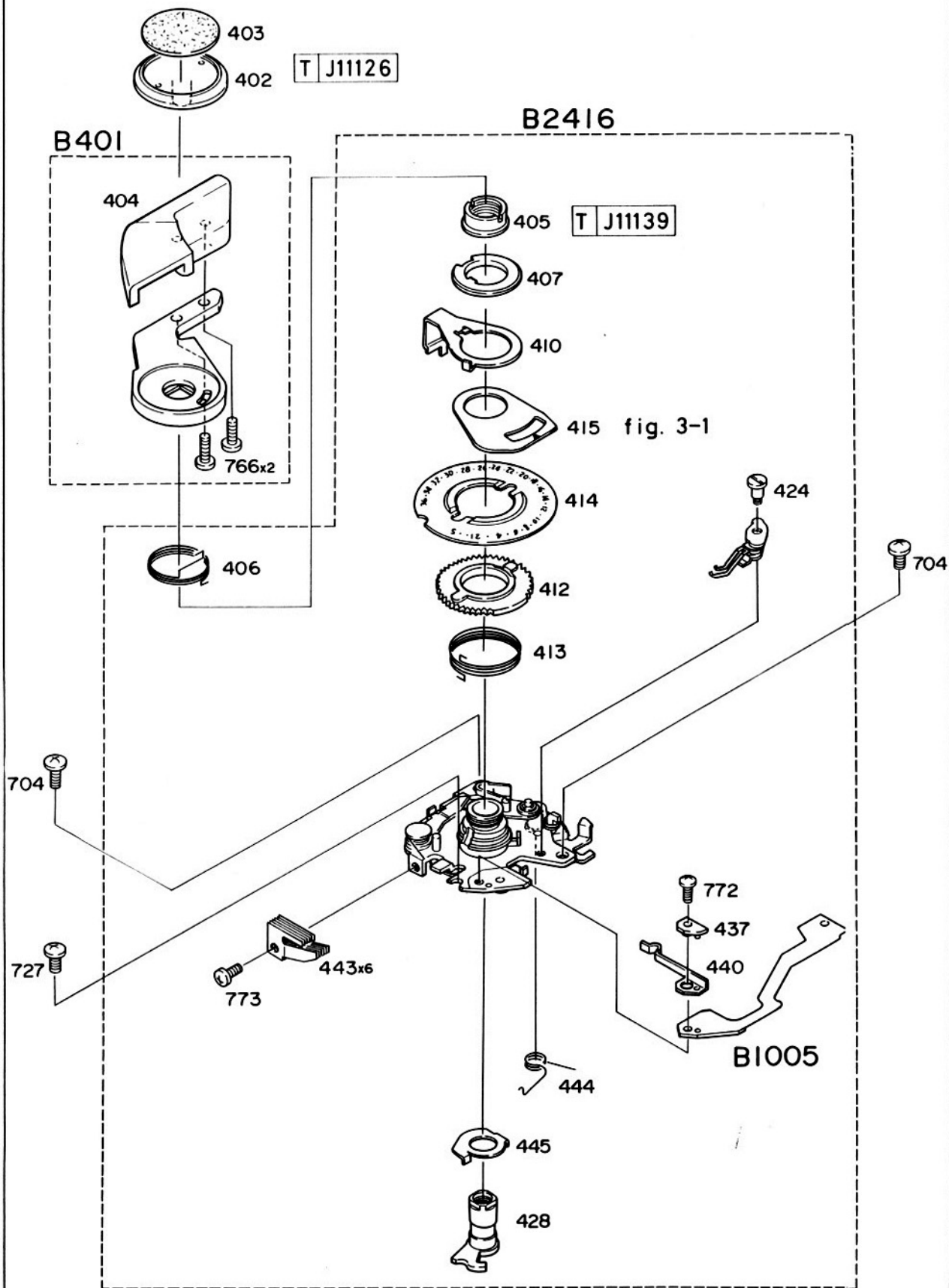

Fig. 3

Fig. 3-1 FRAME-COUNTER INDEX #415 POSITION

To be aligned 1/2 or more of one full calibration mark of counter scale.



3-1 FILM-ADVANCE LEVER UNIT INSTALLATION

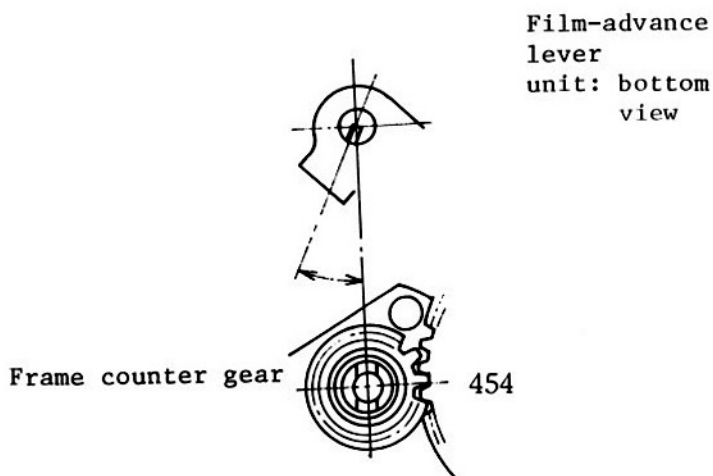
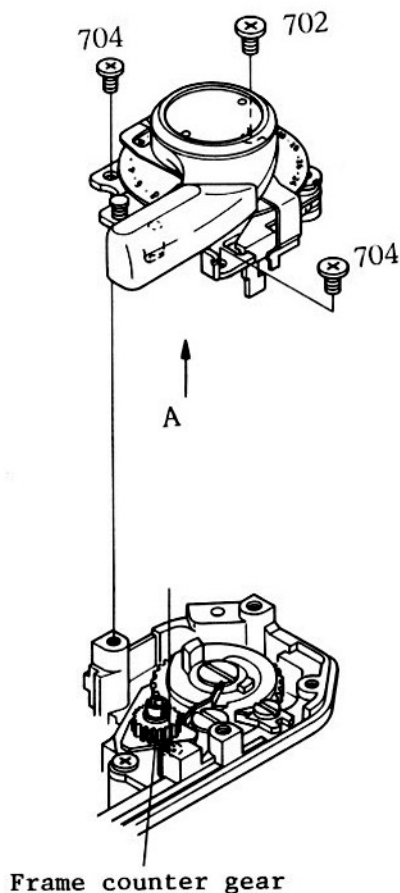

Place Film-advance lever unit toward left-upper side after installation.

3-2 FILM-ADVANCE LEVER UNIT FPC B1005 SOLDERING

Route Film-advance lever unit FPC B1005 under the film-advance lever unit and secure it with Release plate spring hook #588. (Refer to Figure 4)

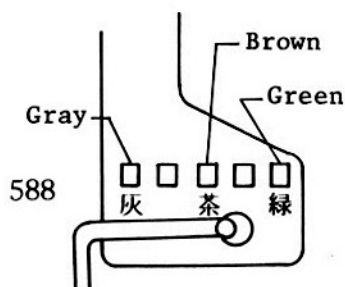

Product: Nikon FA Digital Camera Service Repair Workshop Manual
 Full Download: <https://www.arepairmanual.com/downloads/nikon-fa-digital-camera-service-repair-workshop-manual/>

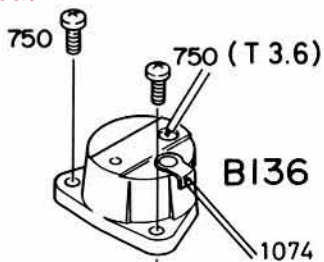

fig. 4-1

Adhesive #501

148

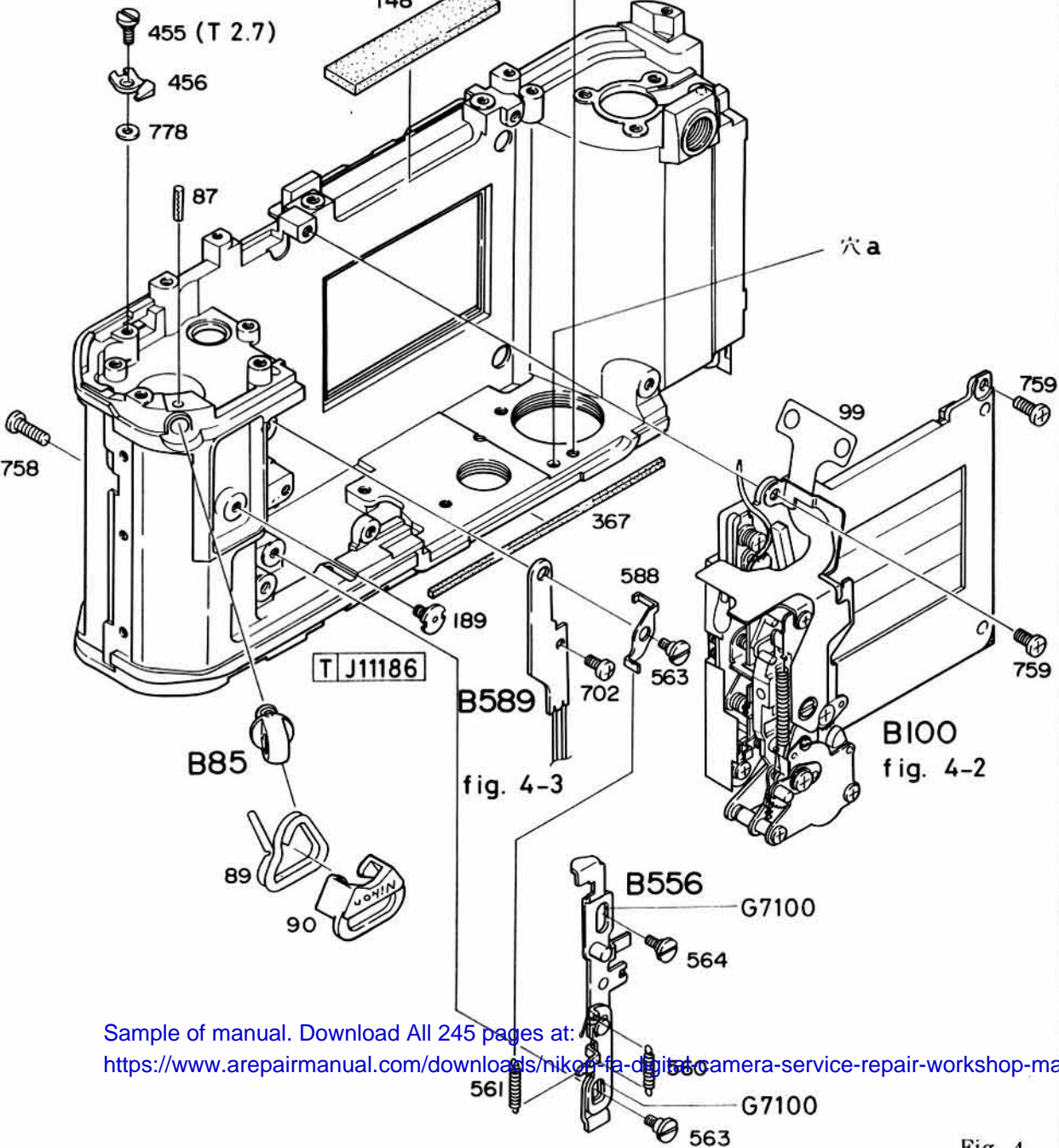

fig. 4-3

B100
fig. 4-2

Sample of manual. Download All 245 pages at: <https://www.arepairmanual.com/downloads/nikon-fa-digital-camera-service-repair-workshop-manual/>