



merCruiser

**SERVICE
MANUAL**

Number 13

MARINE ENGINES

GM 4 Cylinder

Product: 1995 Mercury MerCruiser Number 13 GM 4 Cylinder Marine Engines Service Repair Workshop Manual
Full Download: <https://www.arepairmanual.com/downloads/1995-mercury-mercruiser-number-13-gm-4-cylinder-marine-engines-service-repair-workshop-manual/>

Sample manual. Download All pages at:
<https://www.arepairmanual.com/downloads/1995-mercury-mercruiser-number-13-gm-4-cylinder-marine-engines-service-repair-workshop-manual/>

Notice

Throughout this publication, “Dangers,” “Warnings” and “Cautions” are used to alert the mechanic to special instructions concerning a particular service or operation that may be hazardous if performed incorrectly or carelessly. Observe them carefully!

These “Safety Alerts” alone cannot eliminate the hazards that they signal. Strict compliance to these special instructions when performing the service, plus “common sense” operation, are major accident prevention measures.

DANGER

DANGER - Immediate hazards which will result in severe personal injury or death.

WARNING

WARNING - Hazards or unsafe practices which could result in severe personal injury or death.

CAUTION

CAUTION - Hazards or unsafe practices which could result in minor personal injury or product or property damage.

Notice to Users of This Manual

This service manual has been written and published by the service department of Mercury Marine to aid our dealers, mechanics and company service personnel when servicing the products described herein.

It is assumed that these personnel are familiar with the servicing procedures of these products, of like or similar products manufactured and marketed by Mercury Marine, and that they have been trained in the recommended servicing procedures for these products which include the use of mechanic's common hand tools and the special Mercury Marine or recommended tools from other suppliers.

We could not possibly know of and advise the service trade of all conceivable procedures by which a service might be performed and of the possible hazards and/or results of each method. We have not undertaken any such wide evaluation. Therefore, anyone who uses a service procedure and/or tool, which is not recommended by the manufacturer, first must completely satisfy himself that neither his nor the product's safety will be endangered by the service procedure selected.

All information, illustrations and specifications contained in this manual are based on the latest product information available at time of publication.

It should be kept in mind, while working on the product, that the electrical system and ignition system are capable of violent and damaging short circuits or severe electrical shocks. When performing any work where electrical terminals could possibly be grounded or touched by the mechanic, the battery cables should be disconnected at the battery.

Any time the intake or exhaust openings are exposed during service they should be covered to protect against accidental entrance of foreign material which could enter the cylinders and cause extensive internal damage when the engine is started.

It is important to note that, during any maintenance procedure, replacement fasteners must have the same measurements and strength as those removed, whether metric or customary. Numbers on the heads of the metric bolts and on surfaces of metric nuts indicate their strength. Customary bolts use radial lines for this purpose, while most customary nuts do not have strength markings. Mismatched or incorrect fasteners can result in damage or malfunction, or possible personal injury. Therefore, fasteners removed should be saved for re-use in the same locations whenever possible. Where the fasteners are not satisfactory for re-use, care should be taken to select a replacement that meets the same specifications as the original.

Engine Mechanical Components

Many of the engine mechanical components are designed for marine applications. Unlike automotive engines, marine engines are subjected to extended periods of heavy load and wide-open-throttle operation and, therefore, require heavy-duty components. Special marine engine parts have design and manufacturing specifications which are required to provide long life and dependable performance. Marine engine parts also must be able to resist the corrosive action of salt or brackish water that will rust or corrode standard automotive parts within a short period of time.

Failure to use recommended Quicksilver service replacement parts can result in poor engine performance and/or durability, rapid corrosion of parts subjected to salt water and possibly complete failure of the engine.

Use of parts other than recommended service replacement parts, will void the warranty on those parts which are damaged as a result of the use of other than recommended replacement parts.

Replacement Parts

⚠ WARNING

Electrical, ignition and fuel system components on MerCruiser Engines and Stern Drives are designed and manufactured to comply with U.S. Coast Guard Rules and Regulations to minimize risks of fire or explosion.

Use of replacement electrical, ignition or fuel system components, which do not comply to these rules and regulations, could result in a fire or explosion hazard and should be avoided.

When servicing the electrical, ignition and fuel systems, it is extremely important that all components are properly installed and tightened. If not, any electrical or ignition component opening would permit sparks to ignite fuel vapors from fuel system leaks, if they existed.

Models Covered In This Manual

MODEL	SERIAL NUMBER
MCM 3.0L	OC856451 And Above
MCM 3.0L /3.0LX	OC868143 And Above

IMPORTANT: Refer To "Engine Identification", Page 3A-7

NOTICE
Refer To Appropriate Stern Drive Manual for
transom assembly and stern drive unit repair.

Service Manual Outline

SECTION 1 - Important Information

- A - General Information
- B - Maintenance
- C - Troubleshooting

SECTION 2 - Removal and Installation

- A - 4 Cylinder 3.0L / 3.0 LX (181 C.I.D.)

SECTION 3 - Engine

- A - G.M. In-Line

SECTION 4 - Electrical Systems

- A - Starting System
- B - Ignition System
- C - Charging System
- D - Instrumentation
- E - Wiring Diagrams

SECTION 5 - Fuel System

- A -Fuel Pump
- B - MerCarb 2-Barrel

SECTION 6 - Cooling and Exhaust

- A - Seawater Cooled Models
- B - Closed Cooled Models
- C - Exhaust Manifolds / Elbows

SECTION 7 - Power Steering

- A - Power Steering

IMPORTANT INFORMATION

1

A

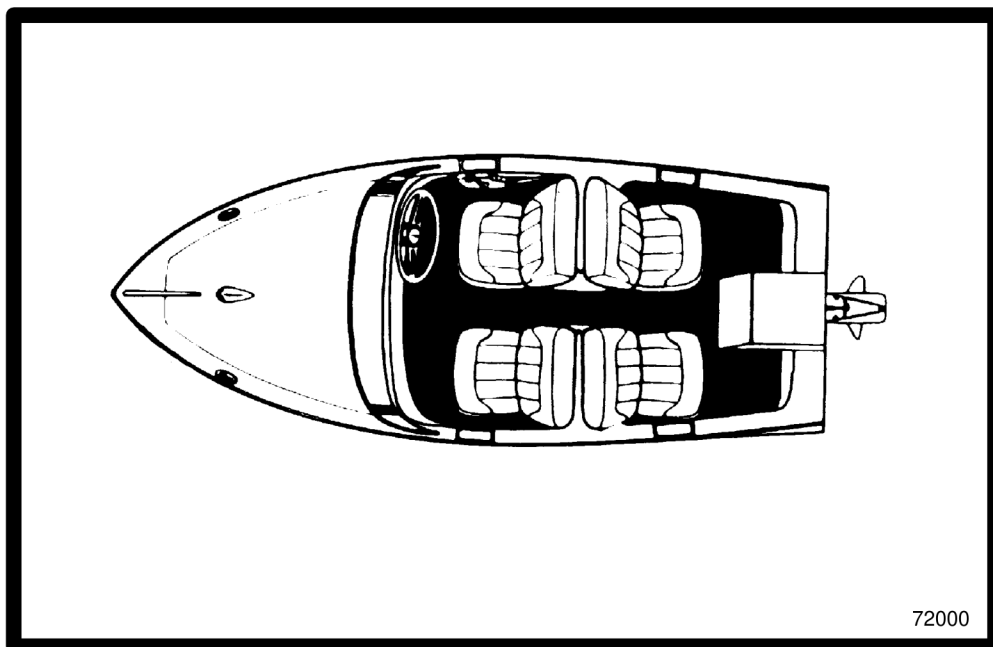

GENERAL INFORMATION

Table of Contents

	Page
Introduction	1A - 1
How To Use This Manual	1A - 1
Page Numbering	1A - 1
How To Read Parts Manual	1A - 2
Directional References	1A - 3
Engine Rotation	1A - 3
Engine Serial Number Locations	1A - 3
Engine Identification	1A - 3
Propeller Information	1A - 3
Water Testing New Engines	1A - 4

	Page
Boat And Engine Performance	1A - 4
Boat Bottom	1A - 4
Marine Fouling	1A - 5
Weight Distribution	1A - 6
Water In Boat	1A - 6
Elevation And Climate	1A - 6

NOTICE

For information and procedures on troubleshooting, refer to SECTION 1C.

NOTICE

Refer to appropriate Stern Drive Service Manual for transom assembly and stern drive unit repair.

Introduction

This comprehensive overhaul and repair manual is designed as a service guide for the models previously listed. It provides specific information, including procedures for disassembly, inspection, assembly and adjustment to enable dealers and service mechanics to repair and tune these engines.

Before attempting repairs or tune-up, it is suggested that the procedure first be read through to gain knowledge of the methods and tools used and the cautions and warnings required for safety.

How to Use This Manual

This manual is divided into sections which represent major components and systems.

Some sections are further divided into parts which more fully describe the component.

Sections and section parts are listed on the "Service Manual Outline" page following "V-8 Models Covered in This Manual" page.

Page Numbering

Two number groups appear at the bottom of each page. Following is an example and description.

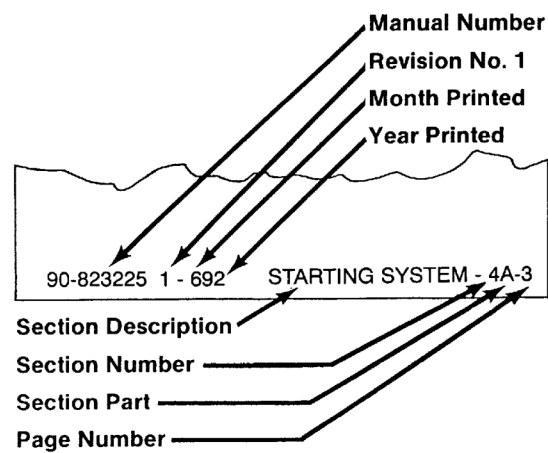

72426

How To Read Parts Manual

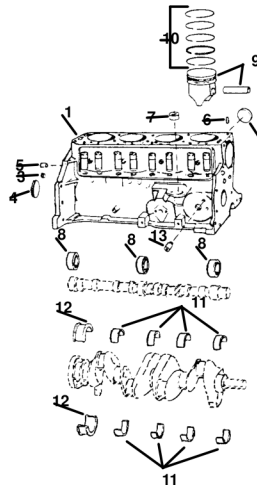

26790

CYLINDER BLOCK AND CAMSHAFT

PART NO.	REF. NO.	DESCRIPTION	QUAN.
● 841-824146 19-34270 17-35465 22-72640 23-85674 22-48556 22-32802	1 2 3 4 5 6 7	CYLINDER BLOCK (See Note) EXPANSION PLUG DOWEL PIN EXPANSION PLUG BEARING UNIT (SET) BUSHING PIPE PLUG	1 8 4 2 1 2 1
22-42796 19-816565 811844 ● 824331 ● 10-824332 ● 824148 ● 31-824150	8 9 10 11 12 13 14	BY-PASS VALVE PLUG LIFTER RETAINER SCREW BALANCED SHAFT BEARING (REAR)	1 1 12 2 4 1 1

e NOTE: 841-824146 Cylinder Block includes only standard pistons, piston rings, crankshaft bearings and camshaft bearings.

A. Part Number: For part ordering - Note N.S.S. for Reference Numbers, (not shown above) - means Not Sold Separately by Mercury Marine, however, in some cases, the G.M. Part Number (for the item) is given in the Description Column.

B. Reference Number: For part Shown on exploded parts view.

C. Description: This is the most important column because it gives:

- 1) Description of Part: Ref. No. 1 is a Cylinder Block Assembly, No. 13 is the Balanced Shaft, etc.
- 2) What parts are included with a certain part: Notice how the Description of Part, for Ref. Nos. 1, and 10 through 13, are at the left side of the column. Description of Part for Ref. Nos. 2 thru 9 are indented under "Cylinder Block". If Ref. No. 1 (Cylinder Block) was ordered, all indented parts (Ref. Nos. 2 thru 9) would come with the part. Ref. Nos. 10 thru 14 would not come with Ref. No. 1 and would have to be ordered separately. If 2 Cylinder Blocks were listed, both cylinder blocks would come with the indented parts. In some cases, an indented part will have another part indented under it. The second indented part will come with the first indented part.

3) Serial number break: If serial number information is listed, check product serial number to ensure that correct part is ordered.

4) Special information: Many times special information will be shown after description such as; L.H. Rotation, R. H. Rotation, Filter up, Filter Down, etc. This will help in selecting the correct part.

D. Quantity: Quantity that has to be ordered.

E. Special Information Block: Additional information, part numbers for gasket sets, etc.

Directional References

Front of boat is bow; rear is stern. Starboard side is right side; port side is left side. In this maintenance manual, all directional references are given as they appear when viewing boat from stern looking toward bow.

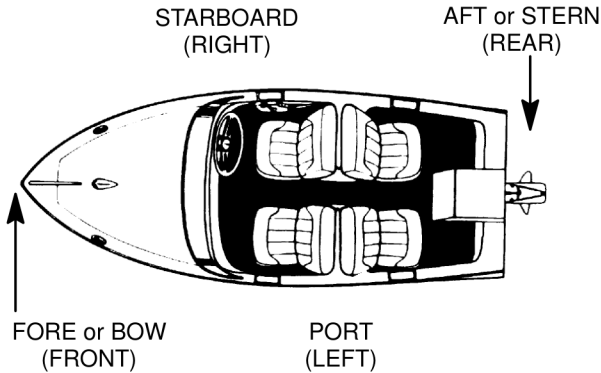

72000

Engine Rotation

Engine rotation is determined by observing flywheel rotation from the rear (stern end) of the engine looking forward (toward water pump end). Propeller rotation is not necessarily the same as engine rotation. When ordering replacement engine, short blocks or parts for engine, be certain to check engine rotation. Do not rely on propeller rotation in determining engine rotation.

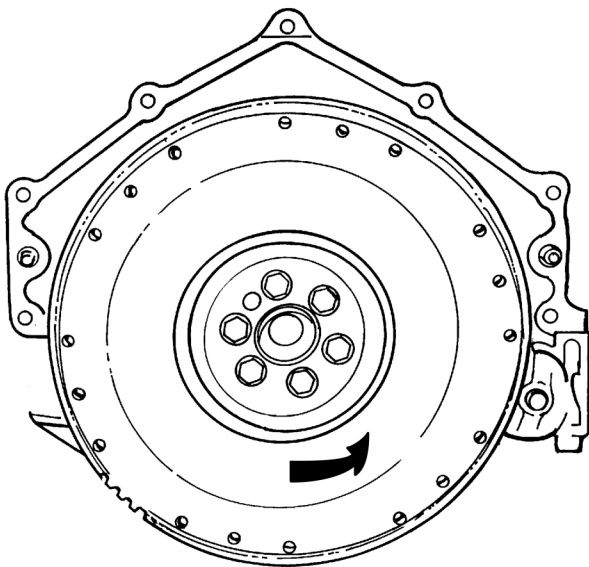

72001

Standard Left-Hand Rotation

Engine Serial Number Locations

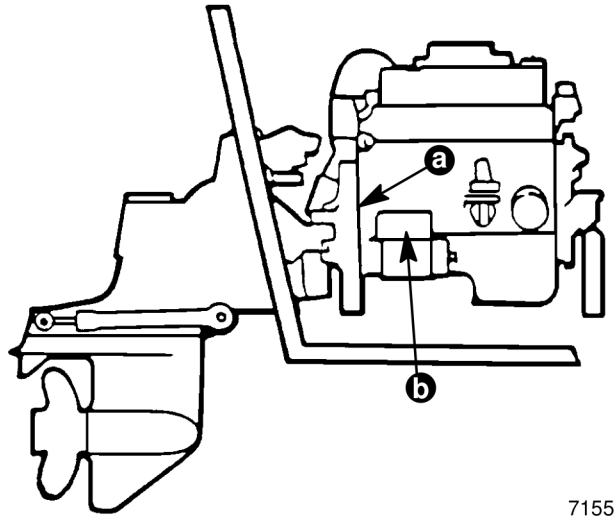

71559

a - Serial Number Plate
b - Starter Motor

Engine Identification

Refer to SECTION 3A for engine block identification.

Propeller Information

Refer to the "Propeller" section in appropriate Mer-Cruiser Stern Drive Service Manual, or order publication 90-86144, "What You Should Know About Quick-silver Propellers."

Changing diameter, pitch or coupling of a propeller will affect engine RPM and boat performance. The blade configuration also will affect performance. Two like propellers, same pitch and diameter, from two different manufacturers also will perform differently.

It is the responsibility of the boat manufacturer and/or selling dealer to equip the boat with the correct propeller to allow the engine to operate within its specified RPM range at wide-open-throttle (W.O.T.).

Because of the many variables of boat design and operation, only testing will determine the best propeller for the particular application.

To test for correct propeller, operate boat (with an average load onboard) at W.O.T. and check RPM with an accurate tachometer. Engine RPM should be near top of the specified range so that, under heavy load, engine speed will not fall below specifications.

If engine exceeds the specified RPM, an increase in pitch and/or diameter is required.

If engine is below rated RPM, a decrease in pitch and/or diameter is required.

Normally, a change of approximately 300 to 500 RPM will be achieved for each single pitch change of a propeller.

CAUTION

If a propeller is installed that does not allow engine RPM to reach the specified full-throttle RPM range, the engine will “labor” and will not produce full power. Operation under this condition will cause excessive fuel consumption, engine overheating and possible piston damage (due to detonation). On the other hand, installation of a propeller, that allows engine to run above the specified RPM limit, will cause excessive wear on internal engine parts which will lead to premature engine failure.

Water Testing New Engines

Use care during the first 20 hours of operation on new MerCruiser engines or possible engine failure may occur. If a new engine has to be water-tested at full throttle before the break-in period is complete, follow this procedure.

1. Run boat up on plane.
2. Advance engine RPM (in 200 RPM increments) until engine reaches its maximum rated RPM.

IMPORTANT: Do not run at maximum RPM for more than 2 minutes.

Boat and Engine Performance

Boat Bottom

For maximum speed, a boat bottom should be as flat as possible in a fore-aft direction (longitudinally) for approximately the last 5 ft. (1.5 m).

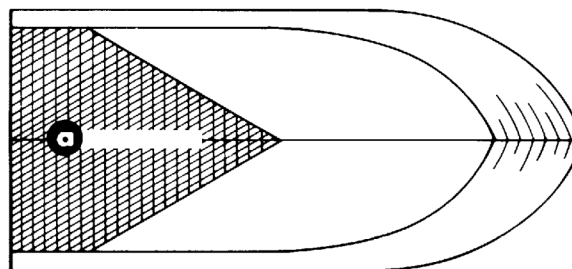

72002

a - Critical Bottom Area

For best speed and minimum spray, the corner between the bottom and the transom should be sharp.

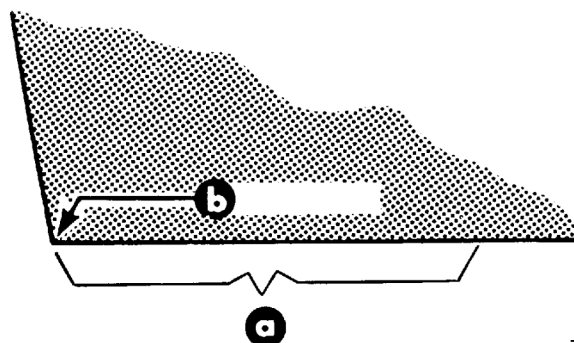

72003

a - Flat
b - Sharp Corner

The bottom is referred to as having a “hook” if it is concave in the fore-and-aft direction. A hook causes more lift on the bottom near the transom and forces the bow to drop. This increases wetted surface and reduces boat speed. A hook, however, aids in planing and reduces any porpoising (rhythmical bouncing) tendency. A slight hook is often built in by the manufacturer. A hook also can be caused by incorrect trailering or storing the boat with support directly under the transom.

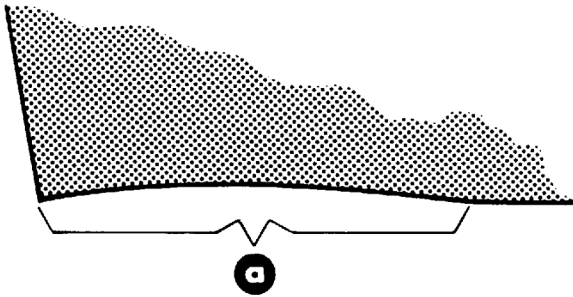

72004

a - Hook

A “rocker” is the reverse of a hook. The bottom is convex or bulged in the fore-and-aft direction. It can cause the boat to porpoise.

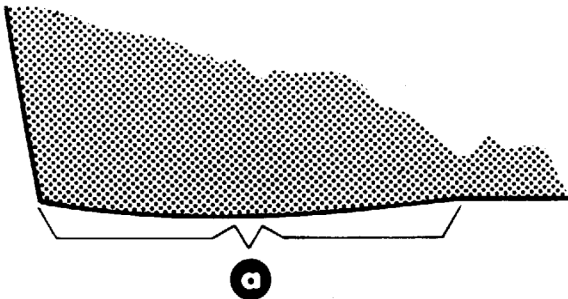

72005

a - Rocker

Any hook, rocker or surface roughness on the bottom, particularly in the all-important center-aft portion will have a negative effect on speed, often several miles per hour on a fast boat.

Marine Fouling

Fouling is an unwanted build-up (usually animal-vegetable-derived) occurring on the boat’s bottom and drive unit. Fouling adds up to drag, which reduces boat performance. In fresh water, fouling results from dirt, vegetable matter, algae or slime, chemicals, minerals and other pollutants. In salt water, barnacles, moss and other marine growth often produce dramatic build-up of material quickly. Therefore, it is important to keep the hull as clean as possible in all water conditions to maximize boat performance.

Antifouling paint, if required, may be applied to boat hull observing the following precautions.

IMPORTANT: DO NOT paint anodes or MerCathode System reference electrode and anode, as this will render them ineffective as galvanic corrosion inhibitors.

CAUTION

Avoid corrosion damage. Do not apply antifouling paint to MerCruiser drive unit or transom assembly.

IMPORTANT: If antifouling protection is required, Tri-Butyl-Tin-Adipate (TBTA) base antifouling paints are recommended on MerCruiser boating applications. In areas where Tri-Butyl-Tin-Adipate base paints are prohibited by law, copper base paints can be used on boat hull and boat transom. Corrosion damage that results from the improper application of antifouling paint will not be covered by the limited warranty. Observe the following:

Avoid an electrical interconnection between the MerCruiser Product, Anodic Blocks, or MerCathode System and the paint by allowing a minimum of 1 in. (26mm) UNPAINTED area on transom of the boat around these items.

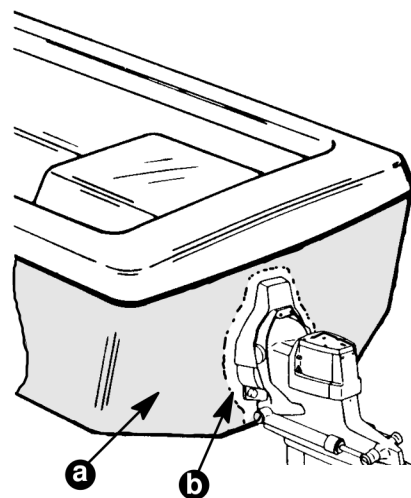

a - Antifouling Paint
b - MINIMUM 1 inch (26 mm) UNPAINTED Area

71176

Weight Distribution

Weight distribution is extremely important; it affects a boat's running angle or attitude. For best top speed, all movable weight - cargo and passengers - should be as far aft as possible to allow the bow to come up to a more efficient angle (3 to 5 degrees). On the negative side of this approach is the problem that, as weight is moved aft, some boats will begin an unacceptable porpoise.

Secondly, as weight is moved aft, getting on plane becomes more difficult.

Finally, the ride in choppy water becomes more uncomfortable as the weight goes aft. With these factors in mind, each boater should seek out what weight locations best suit his/her needs.

Weight and passenger loading placed well forward increases the "wetted area" of the boat bottom and, in some cases, virtually destroys the good performance and handling characteristics of the boat. Operation in this configuration can produce an extremely wet ride, from wind-blown spray, and could even be unsafe in certain weather conditions or where bow steering may occur.

Weight distribution is not confined strictly to fore and aft locations, but also applies to lateral weight distribution. Uneven weight concentration to port or starboard of the longitudinal centerline can produce a severe listing attitude that can adversely affect the boat's performance, handling ability and riding comfort. In extreme rough water conditions, the safety of the boat and passengers may be in jeopardy.

Water in Boat

When a boat loses performance, check bilge for water. Water can add considerable weight to the boat, thereby decreasing the performance and handling.

Make certain that all drain passages are open for complete draining.

Elevation and Climate

Elevation has a very noticeable effect on the wide-open-throttle power of an engine. Since air (containing oxygen) gets thinner as elevation increases, the engine begins to starve for air. Humidity, barometric pressure and temperature do have a noticeable effect on the density of air. Heat and humidity thin the air. This phenomenon can become particularly annoying when an engine is propped out on a cool dry day in spring and later, on a hot, sultry day in August, does not have its normal performance. (See chart.)

Although some performance can be regained by dropping to a lower pitch propeller, the basic problem still exists. The propeller is too large in diameter for the reduced power output. The experienced marine dealer or a Quicksilver Propeller Repair Station can determine how much diameter to remove from a lower-pitch propeller for specific high-elevation locations. In some cases, a gear-ratio change to the drive unit to more reduction is possible and very beneficial. It is a known fact that weather conditions exert a profound effect on power output of internal combustion engines. Therefore, established horsepower ratings refer to the power that the engine will produce at its rated RPM under a specific combination of weather conditions.

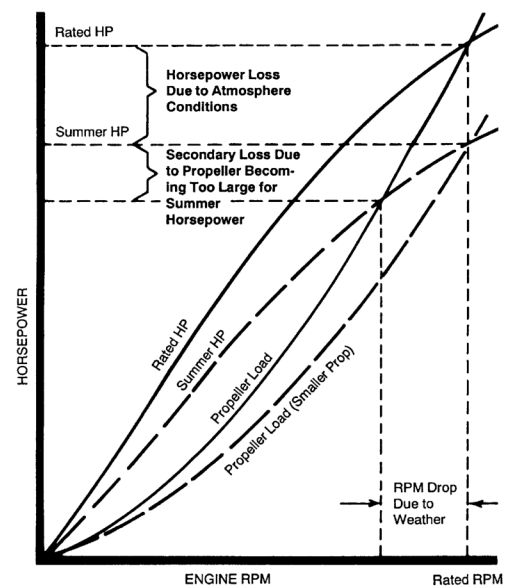

72006

IMPORTANT INFORMATION

1

B

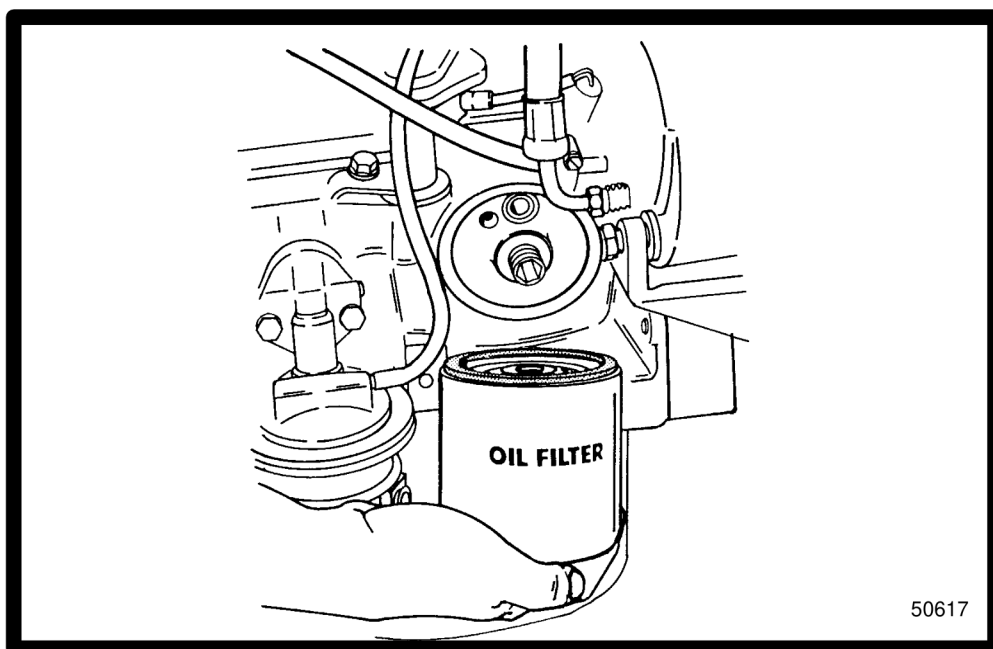

50617

MAINTENANCE

Table of Contents

	Page
Maintenance Schedule	1B - 1
To Be Done by Owner	1B - 1
Maintenance Schedule (Continued)	1B - 2
To Be Done by Dealer	1B - 2
Tune-Up Specifications	1B - 3
Fluid Capacities	1B - 4
4 Cylinder	1B - 5
20-Hour Break-In Period	1B - 5
After 20 Hour Break-In Period	1B - 5
20-Hour Checkup	1B - 5
Fuel, Oil, Fluid, and Coolant Specifications	1B - 6
Fuel	1B - 6
Gasoline/Alcohol Blends	1B - 7
Effects of Gasoline/Alcohol Blends on Marine Engines	1B - 7
Boat/Motor Storage	1B - 7
Winter Storage	1B - 7
Warranty	1B - 7
Continuing Evaluations	1B - 7
Test For Alcohol Content In Gasoline	1B - 7
Crankcase Oil	1B - 8
Priming Engines with Oil	1B - 8
Power Steering Fluid	1B - 8
Coolant for Closed Cooling System	1B - 9
Maintaining Crankcase Oil Level	1B - 9
Overfilled Engine Crankcase	1B - 9

	Page
Checking Engine Oil Level/Filling	1B - 9
Changing Oil and Filter	1B - 9
Maintaining Power Steering Pump	
Fluid Level	1B - 10
With Engine Warm	1B - 10
With Engine Cold	1B - 10
Filling and Bleeding Power Steering System	1B - 11
Maintaining Closed Cooling	
Coolant Level	1B - 11
Flushing Cooling System	1B - 11
Lubrication	1B - 13
Throttle Cable	1B - 13
Models with 2 Barrel Carburetor	1B - 13
Shift Cable	1B - 13
Engine Coupler/U-Joint Shaft Splines	1B - 14
Audio Warning System	1B - 14
Maintenance	1B - 14
Cold Weather or Extended Storage	1B - 14
Precautions	1B - 14
Layup	1B - 15
Draining Instructions	1B - 16
Draining Seawater (Raw-Water) Cooled Models	1B - 16
Draining Seawater Section of Closed Cooled (Coolant) Models	1B - 18
Recommissioning	1B - 19

NOTICE

For information and procedures on troubleshooting, refer to SECTION 1C.

Maintenance Schedule

Always disconnect battery cables from battery BEFORE working around electrical system components to prevent injury to yourself and damage to electrical system should a wire be accidentally shorted.

To Be Done by Owner

TASK	INTERVAL	
Cooling System - Flush seawater section	Saltwater: After each use	
Seawater strainer	Clean as required	
Power package exterior surfaces - clean and paint	Once a year	
Engine crankcase oil - check level	Weekly	
Closed cooling coolant - check level		
Power steering fluid - check level		
Stern drive unit oil - check level		
Battery check level and inspect for damage		
Fuel pump sight tube - check that no fuel is present		
Power trim pump oil - check level		
Anodes - inspect for erosion		
Drive belts (all) - inspect condition and check tension		Every 100 hours or 120 days, whichever occurs first
Propeller shaft - lubricate		Saltwater: Every 50 hours or 60 days, whichever occurs first.
Power package exterior surfaces - spray with rust preventive	Freshwater: Every 100 hours or 120 days, whichever occurs first.	
Power package exterior surfaces - clean and paint	Once a year	
Cooling system - flush seawater section	Saltwater: after each use	

Maintenance Schedule (Continued)

To Be Done by Dealer

TASK	INTERVAL
20-Hour checkup (NOTE 1)	20 hours
Seawater pickup pump - disassemble and inspect	Whenever insufficient seawater flow is suspected. (if operating temperature exceeds normal range)
Flame arrestor and crankcase ventilation hose - clean and inspect	Every 100 hours or once yearly, whichever occurs first
Stern drive unit oil - change	
Gimbal ring clamping screws - retorque to 40 lb. ft. (54 N·m)	
Engine alignment - check	
Transom gimbal housing assembly swivel shaft and gimbal bearing - lubricate	
Engine coupling, universal joint shaft splines - lubricate (see NOTE 2)	
Crankcase oil and filter - change	
Ignition system - clean and inspect condition	
Universal joint cross bearings - lubricate	
Steering system - lubricate and inspect for loose, damaged or missing parts.	Saltwater: Every 50 hours or 60 days, whichever occurs first. Freshwater: Every 100 or once yearly, whichever occurs first.
Electrical system - check for loose or damaged wiring.	
Continuity circuit - check components for loose connections, broken or frayed wires.	
Shift, throttle cables and linkages - lubricate and inspect for loose, damaged or missing parts.	
Cooling system hoses and clamps - inspect for damage and deterioration. Check hose clamps for tightness.	
Engine exhaust system - inspect for damage, deterioration and restrictions. Check hose clamps for tightness.	
Ignition system - check timing and adjust if needed.	Once a year
Fuel filters - replace	
Steering head and remote control - inspect and lubricate.	
Quicksilver Mercathode system - test output	
Closed cooling coolant - test for alkalinity.	
Heat exchanger - Clean seawater section	
Carburetor - inspect and adjust	
Drive unit bellows and clamps - inspect	
Closed cooling coolant - replace	

NOTE 1: For a list of 20 Hour Check up maintenance items to be performed, see "Important Information" section of this manual.

NOTE 2: Refer to "Lubrication" later in this section for engine coupler lubrication and/or related information

Tune-Up Specifications

Model	MCM 3.0L	MCM 3.0LX
Propshaft Horsepower Ratings (Kilowatts)	115 (86)	135 (101)
Number Of Cylinders	4	
Displacement	181 CID (3.0L)	
Bore/Stroke	4.00 in./3.60 in. (101.6/91.4 mm)	
Compression Ratio	9.25:1	
Compression Pressure	140 PSI (966 kPa)	
Idle RPM (in Forward Gear)	650-700	
Maximum RPM (at W.O.T.)	4200-4600	4400-4800
Oil Pressure (at 2000 RPM)	30-60 PSI (207-414 kPa)	
Min. Oil Pressure (at Idle)	5 - 6-1/2 PSI (35-44 kPa)	
Fuel (Pump) Pressure	12 Volt Negative (-) Ground	
Min. Battery Cold Cranking Amperes	375 cca / 475 mca / 90 Ah	
Firing Order	1-3-4-2	
Spark Plug Type	AC-MR43T Champion RV15YC4 NGK BR6FS	AC-MR43LTS Champion RS9YC NGK BPR6EFS
Spark Plug Gap	.035 In. (0.9 mm)	
Timing (at Idle RPM)	Breaker Points Ignition	8° BTDC
	DDIS Ignition	8° BTDC
	Delco EST Ignition	1° BTDC (NOTE)
Preliminary Idle Mixture	1 -1/4 Turns	
Thermostat	143°F (62° C)	
Dwell	39° - 45°	
Breaker Point Gap	.016 in. (0.5 mm)	
Breaker Point Spring Tension	20-27 oz. (567 - 765 g)	

NOTE: Timing must be set using a special procedure as outlined in the appropriate Service Manual. Timing cannot be properly set using the conventional method.

L.H. ROTATION FIRING ORDER

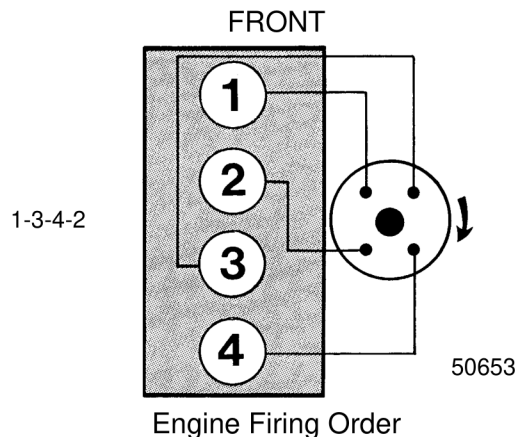

Fluid Capacities

NOTICE

All capacities are approximate fluid measures.

MCM (Stern Drive) Model	All Models
Crankcase Oil ¹ (with filter)	4 U.S. Qts. (3.8 L)
Seawater Cooling System ²	9 U.S. Qts. (3.8 L)
Closed Cooling System	9 U.S. Qts. (8.5 L)

¹ Always use dipstick to determine exact quantity of oil required

² Seawater cooling system capacity information is for winterization use only

4 Cylinder

20-Hour Break-In Period

IMPORTANT: The first 20 hours of operation is the engine break-in period. Correct break-in is essential to obtain minimum oil consumption and maximum engine performance. During this break-in period, the following rules must be observed:

- Do not operate below 1500 RPM for extended periods of time for first 10 hours. Shift into gear as soon as possible after starting and advance throttle above 1500 RPM if conditions permit safe operation.
- Do not operate at one speed consistently for extended periods.
- Do not exceed 3/4 throttle during first 10 hours. During next 10 hours, occasional operation at full throttle is permissible (5 minutes at a time maximum).
- Avoid full throttle acceleration from idle speed.
- Do not operate at full throttle until engine reaches normal operating temperature.
- Frequently check crankcase oil level. Add oil if needed. It is normal for oil consumption to be high during break-in period.
- After 20-hour break-in period, drain crankcase oil and replace oil filter (see "Maintenance"). Fill crankcase with correct oil (see "Specifications").

After 20 Hour Break-In Period

To help extend the life of your MerCruiser power package, the following recommendations should be considered:

- Use a propeller that allows the engine to operate at or near the top of the maximum RPM range (See Specifications) when at full throttle with a normal boat load.
- Operation at 3/4 throttle setting or lower is recommended. Refrain from prolonged operation at maximum (full throttle) RPM.

20-Hour Checkup

After first 20 hours of operation, an Authorized MerCruiser Dealer should be contacted for the following maintenance. The boat owner is responsible for any charges.

- Change crankcase oil and filter.
- Check all fluid levels.
- Cooling Systems - Inspect all hoses for damage and deterioration; check all hose clamps for adequate tightness.
- Check carburetor adjustment.
- Inspect ignition system and timing.
- Check for loose, missing or damaged parts.
- Check shift and throttle cable adjustments - Lubricate and inspect for loose, damaged or missing parts.
- Steering System - Lubricate and inspect for loose, damaged or missing parts.
- Inspect all drive belts.
- Check engine alignment.
- Complete Engine Exhaust System - Inspect externally for damage and deterioration; check all hose clamps for adequate tightness.
- Front engine mounts-Tighten securely and ensure that thejam nut is tight.
- Rear mounts-Check torque to 35-40 lb. ft. (47-54 N·m).
- Retorque gimbal ring clamping U-bolt to 55 lb. ft. (74 N·m).

Fuel, Oil, Fluid, and Coolant Specifications

Fuel

⚠ CAUTION

Use of improper gasoline can damage the engine seriously. Engine damage that results from use of improper gasoline is considered misuse of the engine and is not covered under MerCruiser Warranty.

USA and Canada

Fuel having a posted pump Octane Rating of 87(R + M)/2 minimum. Premium gasoline [92 (R + M)/2] is also acceptable. DO NOT use leaded gasoline.

Outside USA and Canada

Fuel having a posted pump Octane Rating of 90 RON minimum. Premium gasoline (98 RON) is also acceptable. If unleaded is not available, use a major brand of leaded gasoline.

Using Reformulated (Oxygenated) Gasolines (USA Only)

This type of gasoline is required in certain areas of the USA. The two types of "oxygenates" used in these fuels is Alcohol (Ethanol) or Ether (MTBE or ETBE). If Ethanol is the "oxygenate" that is used in the gasoline in your area, refer to "Gasoline Containing Alcohol" also.

These "Reformulated Gasolines" are acceptable for use in your MerCruiser engine.

Gasolines Containing Alcohol

The fuel system components on your MerCruiser engine will withstand up to 10% content in the gasoline. We do not know what percentage your boat manufacturer for specific recommendations on the boats fuel system components (fuel tanks, fuel lines, and fittings).

Gasolines containing alcohol, either methyl alcohol (methanol) or ethyl alcohol (ethanol) may cause increased:

- Corrosion of metal parts.
- Deterioration of elastomer and plastic parts.
- Fuel permeation through flexible fuel lines.
- Wear and damage of internal engine parts.
- Starting and operating difficulties.

Some of these adverse effects are due to the tendency of gasolines containing alcohol to absorb moisture from the air, resulting in a phase of water and alcohol separating from the gasoline in the fuel tank.

The adverse effects of alcohol are more severe with methyl alcohol (methanol) and are worse with increasing alcohol content.

⚠ WARNING

Fire and Explosion Hazard: Fuel leakage from any part of the fuel system can be a fire and explosion hazard which can cause serious bodily injury or death. Careful periodic inspection of the entire fuel system is mandatory, particularly after storage. All fuel system components including fuel tanks (whether plastic, metal or fiberglass), fuel lines, primer bulbs, fittings, fuel filters and carburetors should be inspected for leakage, softening, hardening, swelling or corrosion. Any sign of leakage or deterioration requires replacement before further engine operation.

Because of possible adverse effects of alcohol in gasoline, it is recommended that only alcohol-free gasoline be used where possible. If only fuel containing alcohol is available, or if the presence of alcohol is unknown, increased inspection frequency for leaks and abnormalities is required.

⚠ WARNING

Avoid gasoline fire or explosion. Improper installation of brass fittings or plugs into fuel pump or fuel filter base can crack casting and/or cause a fuel leak.

GASOLINE/ALCOHOL BLENDS

Many new motor vehicle owner manuals are warning about the potential damage from using gasoline containing alcohol, especially METHANOL. They cite possible fuel system damage and performance problems. These are just two of the hazards that may be caused by alcohol. These same problems as well as the additional safety risk of fire and explosion from fuel system leaks apply to marine inboard engines. METHANOL is more severe in its bad effect than is ETHANOL. Alcohol is also more severe in older engines since newer engines have materials which are more resistant to alcohol.

EFFECTS OF GASOLINE/ALCOHOL BLENDS ON MARINE ENGINES

Corrosion of metals may result from use of alcohol-gasoline blends. Portable or permanently installed fuel tanks of metal or fiberglass, fuel filters, fuel lines and float bowls may be affected by alcohol blended fuels. Many fiberglass fuel tanks are slowly dissolved by alcohol, leading immediately to filter and carburetor plugging and eventually to tank failure.

Fuels containing alcohol will absorb moisture from the air. At first, this moisture will remain in solution, but once the water content of the fuel has built up to about one-half of one percent, it will separate out (phase separation), bringing the alcohol with it. This alcohol-water mixture settles to the bottom of the fuel tank and if this mixture gets into the engine, the engine can be seriously damaged internally, as it may wash the protective film of oil off the bore of any cylinder that it enters. Before the engine can be restarted, it is necessary to remove the separated alcohol and water layer, flush out the fuel system with clean fuel and remove and dry the spark plugs.

BOAT/MOTOR STORAGE

When operating a MerCruiser engine on gasoline containing alcohol, storage of gasoline in the fuel tank for long periods of time should be avoided.

Long periods of storage, common to boats, create unique problems. In cars, gasoline/alcohol blend fuels normally are consumed before they can absorb enough moisture to cause trouble, but boats often sit idle long enough for phase separation to take place. In addition, internal corrosion may take place during storage if alcohol has washed protective oil films from internal components.

WINTER STORAGE

If boat is to be placed in winter storage, carburetors must be run dry at idle RPM. Permanent fuel tanks should be drained completely and Quicksilver Gasoline Stabilizer and Conditioner added to any fuel remaining in the tank. Portable fuel tanks should be emptied completely.

WARRANTY

Performance problems and fuel system or other damage resulting from the use of gasoline-alcohol blended fuels are not the responsibility of MerCruiser and will not be covered under our warranty.

CONTINUING EVALUATIONS

The effects of gasoline with ETHANOL and METHANOL are still being evaluated by the United States Coast Guard, the National Marine Manufacturers Association (NMMA), Mercury Marine and other engine and boat manufacturers.

We have recommended pump posting of alcohol content of gasoline. Further we recommend using gasoline known not to contain any METHANOL or ETHANOL when possible.

TEST FOR ALCOHOL CONTENT IN GASOLINE

The following is an acceptable and widely used field procedure for the detection of alcohol in gasoline. Use any small transparent bottle or tube that can be capped and is, or can be, provided with graduations or a mark at about 1/3 full. A pencil mark on a piece of adhesive tape may be used.

Procedure:

1. Fill the container with water to the mark.
2. Add fuel almost to fill the container, leaving some air space, then cap the container. The proportions of fuel to water are not critical, but there should be 2 to 3 times as much fuel as water.
3. Shake container vigorously and allow it to sit **upright for 3 to 5 minutes**. If the volume of water appears to have increased, alcohol is present. If you are not sure, there is no need for concern. If the dividing line between water and fuel becomes cloudy, use the middle of the cloudy band.

Crankcase Oil

To help obtain optimum engine performance and to provide maximum protection, we strongly recommend the use of Quicksilver 4-Cycle Marine Engine Oil. If not available, a good grade, straight weight, detergent automotive oil of correct viscosity, with an API classification of SF or SG, may be used.

The following chart is a guide to crankcase oil selection. Oil filter should always be changed with oil.

In those areas where recommended straight weight oil is not available, a multi-viscosity 20W-40 (SF or SG) or, as a second but less preferable choice, 20W-50 (SF or SG) may be used.

IMPORTANT: The use of non-detergent oils, multi-viscosity oils (other than 20W-40 or 20W-50), low quality oils or oils which contain solid additives specifically are not recommended.

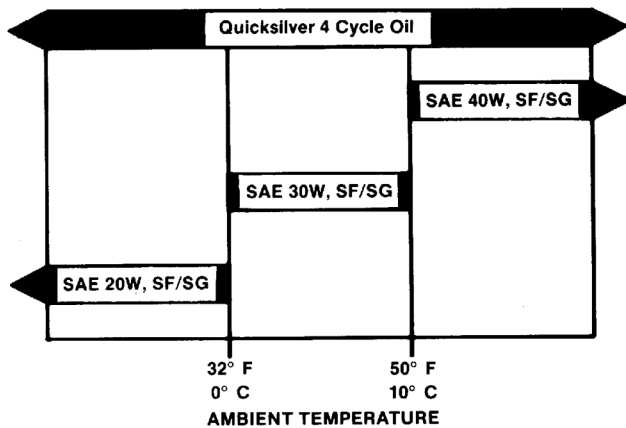

72010

Priming Engines with Oil

IMPORTANT: This applies to all power packages that have not been run within 6 months, replacement of partial engines or after rebuilding an engine.

Tools Required

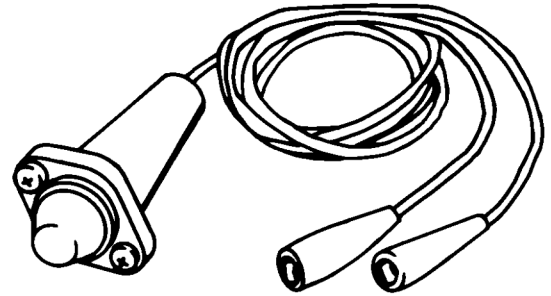

71089

91-52024A1 Remote Starter Switch

1. Fill crankcase to proper level with recommended engine oil.
2. Remove spark plugs.
3. Leave ignition Key in "OFF" position.
4. Connect remote starter switch to large 12V terminal (RED battery cable) and small terminal (YELLOW-RED wire) on starter motor.
 - a. If Remote Starter Switch is not available, disconnect PURPLE wire from ignition coil before using key switch to crank the engine over. Tape terminal on Purple wire to prevent it from touching ground.
5. Crank engine over for 15 seconds, then allow starter motor to cool for 1 minute. Watch that starter motor does not overheat.
6. Repeat until a total of 45 seconds of crank time is achieved.
7. Remove Remote Starter Switch.
 - a. If key switch was used, reconnect Purple wire to ignition coil.
8. Install spark plugs and wires.
9. With cooling water being supplied to seawater pump, start engine.

Power Steering Fluid

Use Quicksilver Power Trim and Steering Fluid, or automatic transmission Fluid (ATF), Dexron III.

Coolant for Closed Cooling System

CAUTION

Alcohol or Methanol base antifreeze or plain water, are not recommended for use in fresh water section of cooling system at any time.

We recommend that the coolant section of closed cooling system be filled with Quicksilver Pre-Mixed Engine Coolant. In areas where the possibility of freezing does not exist, it is permissible to use a solution of rust inhibitor and water (mixed to manufacturer's recommendations).

Maintaining Crankcase Oil Level

Overfilled Engine Crankcase

Overfilled crankcases (oil level being too high) can cause a fluctuation or drop in oil pressure and rocker arm "clatter" on MerCruiser engines. The over-full condition results in the engine crankshaft splashing and agitating the oil, causing it to foam (become aerated). The aerated oil causes the hydraulic valve lifters to "bleed down." This, in turn, results in rocker arm "clatter" and loss of engine performance, due to the valves not opening properly.

Care must be taken when checking engine oil level. Oil level must be maintained between the ADD mark and the FULL mark on the dipstick. To ensure that you are not getting a "false reading," make sure the following steps are done before checking the oil level.

- Boat "at rest" in the water, or
- If boat is on a trailer, raise or lower bow until the boat is setting at the approximate angle that it would be if setting "at rest" in the water.
- Allow sufficient time for oil to drain into the crankcase if engine has just been run or oil has just been added.

Checking Engine Oil Level/Filling

IMPORTANT: ENGINE CRANKCASE OIL MUST BE CHECKED AT INTERVALS SPECIFIED IN "MAINTENANCE SCHEDULE" CHART. It is normal for an engine to use a certain amount of oil in the process of lubrication and cooling of the engine. The amount of oil consumption is greatly dependent upon engine speed, with consumption being highest at wide-open-throttle and decreasing substantially as engine speed is reduced.

1. Allow oil to drain back into oil pan - approximately 5 minutes.
2. Remove dipstick. Wipe clean and reinstall. Push dipstick all the way into dipstick tube.
3. Remove dipstick and note the oil level.
4. Oil level must be between the FULL and ADD marks.
5. If oil level is below ADD mark, proceed to Steps 6 and 7.
6. Remove oil filler cap from valve rocker arm cover.
7. Add required amount of oil to bring level up to, but not over, the FULL mark on dipstick.

Changing Oil and Filter

1. Start engine and run until it reaches normal operating temperatures.

IMPORTANT: Change oil when engine is warm from operation, as it flows more freely, carrying away more impurities.

2. Stop engine.
3. Remove drain plug from oil pan or from oil drain hose.

NOTE: *If drain plug is not accessible because of boat construction, oil may be removed through dipstick tube, using a Quicksilver Crankcase Oil Pump.*

4. After oil has drained completely, reinstall drain plug (if removed) and tighten securely.
5. Remove and discard oil filter and its sealing ring.

- Coat sealing ring on new filter with engine oil, and install. Tighten filter securely (following filter manufacturer's instructions). Do not over-tighten.

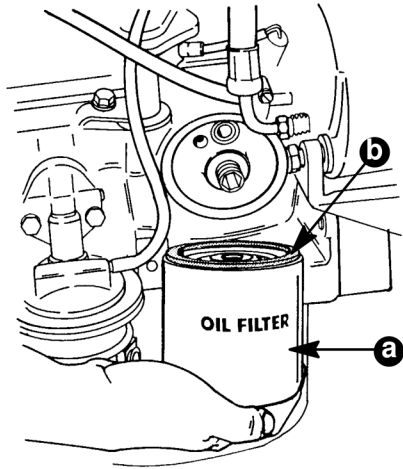

50617

- a - Oil Filter
- b - Sealing Ring

- Fill crankcase with oil.
- Start engine and check for leaks.

Maintaining Power Steering Pump Fluid Level

With Engine Warm

- Stop engine and position drive unit so that it is straight back.
- Remove fill cap/dipstick from power steering pump and note fluid level.

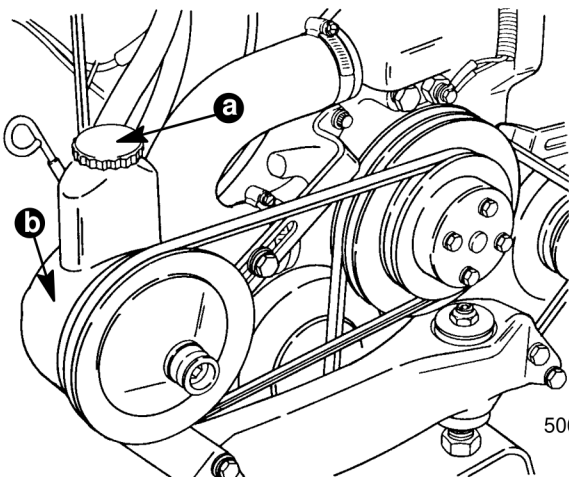

50629

- a - Fill Cap/Dipstick
- b - Power Steering Pump

- Level should be between the FULL HOT mark and ADD mark on dipstick.

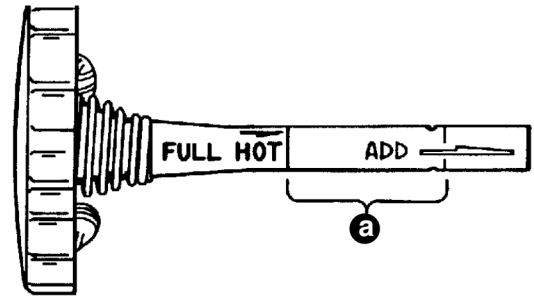

72518

- a - Proper Fluid Level with Engine Warm

- If level is below ADD mark, but fluid is still visible in pump reservoir, add required amount of Quicksilver Power Trim and Steering Fluid or automatic transmission fluid (ATF), Dexron, or Dexron II, through fill cap opening, to bring level up to FULL HOT mark on dipstick. **DO NOT OVERFILL.**
- If fluid is not visible in reservoir, a leak exists in the power steering system. Find cause and correct.

With Engine Cold

- With engine stopped, position drive unit so that it is straight back.
- Remove fill cap/dipstick from power steering pump and note fluid level.
- Level should be between FULL COLD mark and bottom of dipstick.

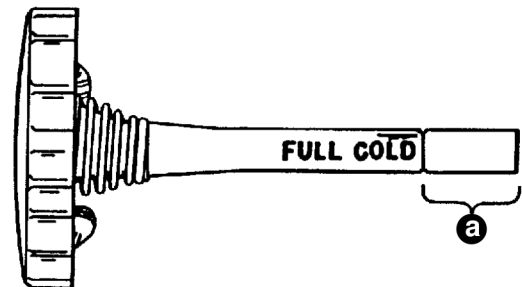

72519

- a - Proper Fluid Level with Engine Cold

- If level is below bottom of dipstick, but fluid is still visible in pump reservoir, add required amount of Quicksilver Power Trim and Steering Fluid or automatic transmission fluid (ATF), Dexron, or Dexron II, through fill cap opening, to bring level up to FULL COLD mark on dipstick. **DO NOT OVERFILL.**
- If fluid is not visible in reservoir, a leak exists in the power steering system. Find cause and correct.

Filling and Bleeding Power Steering System

IMPORTANT: Power steering system must be filled exactly as explained in the following to be sure that all air is bled from the system. All air must be removed, or fluid in pump may foam during operation and be discharged from pump reservoir. Foamy fluid also may cause power steering system to become spongy, which may result in poor boat control.

1. With engine stopped, position drive unit so that it is straight back. Remove fill cap/dipstick from power steering pump. Add Quicksilver Power Trim and Steering Fluid or automatic transmission fluid (ATF), Dexron, or Dexron II, as required, to bring level up to FULL COLD mark on dipstick.

IMPORTANT: Use only Quicksilver Power Trim and Steering Fluid or automatic transmission fluid (ATF), Dexron, or Dexron II in power steering system.

2. Turn steering wheel back and forth to end of travel in each direction several times, then recheck fluid level and add fluid, if necessary.
3. Install vented fill cap.

CAUTION

DO NOT operate engine without water being supplied to seawater pickup pump, or pump impeller may be damaged and subsequent overheating damage to engine may result.

4. Start engine and run at fast idle (1000-1500 RPM) until engine reaches normal operating temperature. During this time, turn steering wheel back and forth to end of travel in each direction several times.
5. Position drive unit so that it is straight back and stop engine. Remove fill cap from pump. Allow any foam in pump reservoir to disperse, then check fluid level and add fluid, as required, to bring level up to FULL HOT mark on dipstick. **DO NOT OVERFILL.** Reinstall fill cap securely.

IMPORTANT: Drive unit must be positioned straight back and power steering fluid must be hot to accurately check fluid level.

6. If fluid is still foamy (in Step 5), repeat Steps 4 and 5 until fluid does not foam and level remains constant.

Maintaining Closed Cooling Coolant Level

WARNING

Allow engine to cool down before removing pressure cap. Sudden loss of pressure could cause hot coolant to boil and discharge violently. After engine has cooled, turn cap 1/4 turn to allow any pressure to escape slowly, then push down and turn cap all the way off.

1. Coolant level in heat exchanger should be full (to bottom of filler neck).

IMPORTANT: When reinstalling pressure cap, be sure to tighten it until it contacts stop on filler neck.

2. Coolant level should be between the ADD and FULL marks on coolant recovery reservoir with the engine at normal operating temperature.

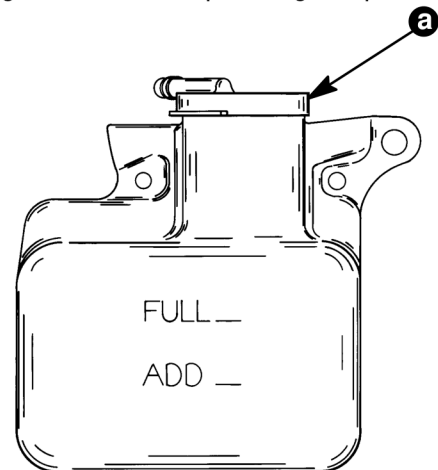

193-HR

a - Coolant Recovery Reservoir

Flushing Cooling System

If engine is operated in salty, polluted, or mineral-laden water, flush cooling system (preferably after each use) to reduce corrosion and prevent the accumulation of deposits in the system. Thoroughly flush cooling system prior to storage.

⚠ WARNING

When flushing cooling system with boat out of the water, be certain that area in vicinity of propeller is clear and that no person is standing nearby. As a precautionary measure, it is recommended that propeller be removed.

⚠ CAUTION

To prevent engine or stern drive unit damage **DO NOT** run engine or drive unit without water being supplied to water intake openings on gear housing, and to seawater pickup pump if so equipped.

1. Connect flushing attachment as follows:

NOTE: If flushing cooling system with boat in water, raise drive unit to trailer position and install flushing attachment. Lower drive unit to full IN/DOWN position.

- Install Quicksilver Flushing Attachment (or equivalent) over water intake openings in gear housing.
- Connect hose between flushing attachment and water tap.

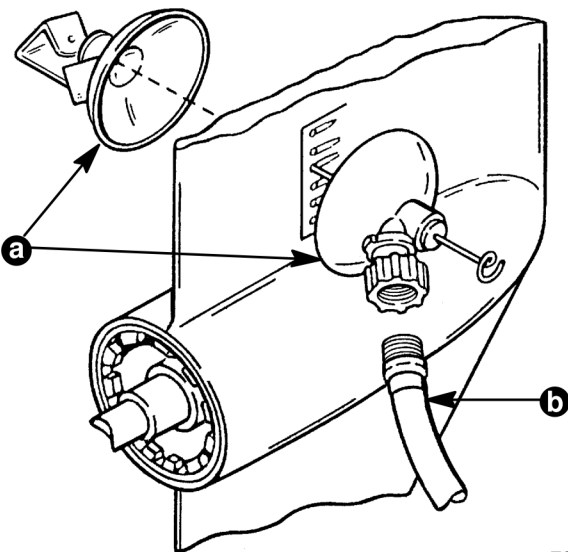

72012

- a - Quicksilver Flushing Attachment
b - Garden Hose

⚠ CAUTION

If cooling system is to be flushed with boat in the water, seacock (if so equipped) must be closed, or water inlet hose must be disconnected and plugged to prevent water from flowing into boat.

- Partially open water tap(s) (approximately 1/2 maximum capacity) and allow drive unit and cooling system to fill completely. Do not use full tap water pressure.

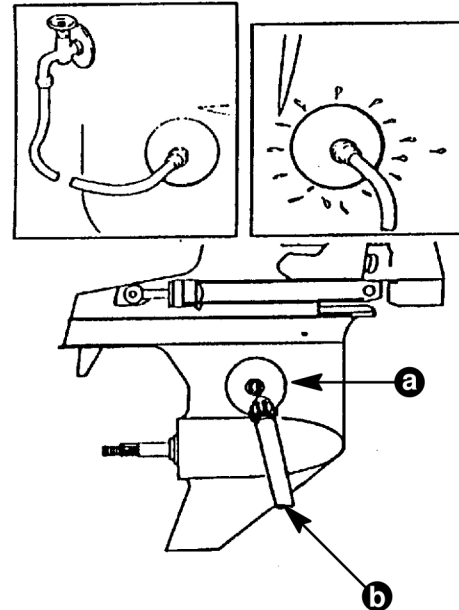

72672

- a - Quicksilver Flushing Attachment
b - Water To Drive Unit

NOTE: Drive unit is full when water is discharged out of drive unit, and/or seawater section of closed cooled system is full when water is discharged through propeller.

⚠ CAUTION

Do not run engine above 1500 RPM when flushing. Suction created by seawater pickup pump may collapse flushing hose, causing engine to overheat.

- Place remote control lever in NEUTRAL position and start the

⚠ CAUTION

Watch temperature gauge at dash to ensure the engine does not overheat.

- Operate engine at idle speed in NEUTRAL gear for 10 minutes or until discharge water is clear, then stop engine.
- Shut off water tap(s).
- Remove hose and flushing attachment from drive unit.:

NOTE: If flushing cooling system with boat in water, raise drive unit to trailer position, to remove flushing attachment. Lower drive unit to full IN/DOWN position after completion.

- Follow instructions “a” or “b.”

⚠ CAUTION

If boat is in the water, seacock (if so equipped) must remain closed until engine is to be restarted, to prevent contaminated water from flowing back into cooling system. If boat is not fitted with a seacock, water inlet hose must remain disconnected and plugged, to prevent water from flowing into cooling system and/or boat. As a precautionary measure, attach a tag to the ignition switch or steering wheel with the warning that the seacock must be opened or the water inlet hose reconnected prior to starting the engine.

- If equipped with seacock:** Observing precaution above, open seacock.
- If NOT equipped with seacock:** Observing precaution above, remove plug from seawater inlet hose and reconnect seawater inlet hose. Tighten hose clamps securely.

Lubrication

Lubricate pivot points with SAE 30W motor oil and cable guide contact surfaces with Quicksilver 2-4-C Marine Lubricant with Teflon.

Throttle Cable

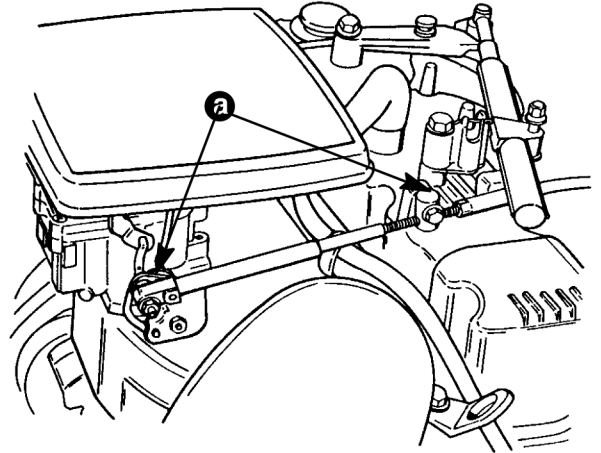

50626

a - Pivot Points

Shift Cable

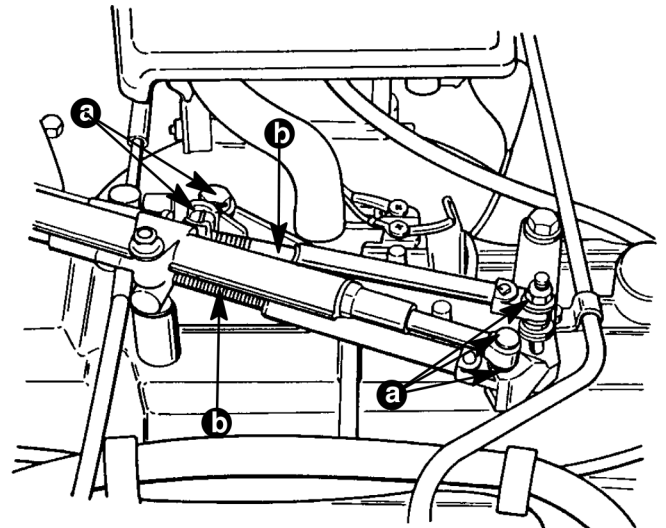

50626

a - Pivot Points
b - Guide Contact Surface

Engine Coupler/U-Joint Shaft Splines

Lubricate coupler and splines with Quicksilver Engine Coupler Spline Grease (92- 816391A4).

IMPORTANT: Stern Drive Unit does not have to be removed to grease coupler.

NOTE: Refer to MerCruiser Stern Drive Service Manual for stern drive unit removal and installation if necessary.

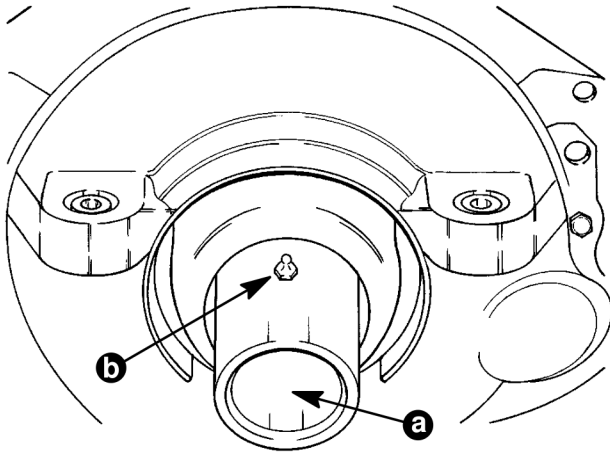

72017

- a - Quicksilver Engine Coupler Spline Grease
- b - Use Grease Fitting if Drive Is Installed

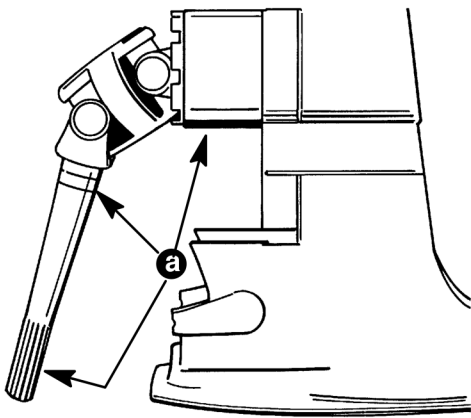

72530

- a - Quicksilver Engine Coupler Spline Grease (If Drive Has Been Removed)

Audio Warning System

Maintenance

Maintenance inspection is the owner's responsibility and must be performed at intervals specified, following:

Fresh Water Areas - Every 50 Hours of operation or 60 days (whichever comes first)

Salt Water Areas - Every 25 hours of operation or 30 days (whichever comes first)

NOTE: Operation in salt water is considered severe service.

1. Check buzzer mounting screws, heat switch and oil pressure switch for adequate tightness. Tighten, if loose, but DO NOT over-tighten.
2. Check all wiring connections to be sure that they are tight and sealed where necessary.

Cold Weather or Extended Storage

Precautions

⚠ WARNING

BE CAREFUL while working on fuel system; gasoline is extremely flammable and highly explosive under certain conditions. Be sure that ignition key is OFF and do not smoke or allow sources of spark and/or open flames in the area.

⚠ WARNING

To prevent a potential fire hazard, be sure that engine compartment is well ventilated and that there are no gasoline vapors present during starting or fogging of engine.

⚠ CAUTION

DO NOT operate engine without water flowing through seawater pickup pump, as pump impeller may be damaged and subsequent overheating damage to engine or stern drive unit may result.