

Product: 2002 Canon LBP-1120 Printer Service Repair Workshop Manual  
Full Download: <https://www.arepairmanual.com/downloads/2002-canon-lbp-1120-printer-service-repair-workshop-manual/>

# LBP-1120

## SERVICE MANUAL

REVISION 0

**Canon**

Sample of manual. Download All 117 pages at:  
<https://www.arepairmanual.com/downloads/2002-canon-lbp-1120-printer-service-repair-workshop-manual/>

### Application

This manual has been issued by Canon Inc. for qualified persons to learn technical theory, installation, maintenance, and repair of products. This manual covers all localities where the products are sold. For this reason, there may be information in this manual that does not apply to your locality.

### Corrections

This manual may contain technical inaccuracies or typographical errors due to improvements or changes in products. When changes occur in applicable products or in the contents of this manual, Canon will release technical information as the need arises. In the event of major changes in the contents of this manual over a long or short period, Canon will issue a new edition of this manual.

The following paragraph does not apply to any countries where such provisions are inconsistent with local law.

### Trademarks

The product names and company names used in this manual are the registered trademarks of the individual companies.

### Copyright

This manual is copyrighted with all rights reserved. Under the copyright laws, this manual may not be copied, reproduced or translated into another language, in whole or in part, without the written consent of Canon Inc.

***COPYRIGHT © 2002 CANON INC.***

***Printed in Japan***

***Imprimé au Japon***

### Caution

Use of this manual should be strictly supervised to avoid disclosure of confidential information.

## **PREFACE**

This Service Manual contains basic information required for after-sales service of the laser beam printer LBP-1120 (hereinafter referred to as the “printer”). This information is vital to the service technician in maintaining the high print quality and performance of the printer.

This manual consists of the following chapters:

- Chapter 1: Product information  
Features, specifications, operation, and installation
  
- Chapter 2: Operation and Timing  
A description of the operating principles and timing sequences of the electrical and mechanical systems.
  
- Chapter 3: The Mechanical System  
Explanation of mechanical operation, disassembly, reassembly and adjustment procedures
  
- Chapter 4: Troubleshooting  
Troubleshooting procedures, reference values and adjustments, maintenance and servicing, etc.
  
- Appendix: General timing chart, general circuit diagram, etc.

Information in this manual is subject to change as the product is improved or redesigned. All relevant information in such cases will be supplied in the Service Information Bulletins.

A thorough understanding of this printer, based on information in this Manual and Service Information bulletins, is required for maintaining its performance and for locating and repairing the causes of malfunctions.



## CONTENTS

### CHAPTER 1 PRODUCT INFORMATION

I.	FEATURES .....	1-1	B.	Cross Section .....	1-6
II.	SPECIFICATIONS .....	1-2	V.	INSTALLATION .....	1-7
	A. Printer .....	1-2	A.	Precautions .....	1-7
III.	<b>!</b> SAFETY INFORMATION .....	1-4	B.	Storage and Handling of EP-22 Cartridge .....	1-8
	A. Handling the Laser/Scanner Unit .....	1-4	VI.	MAINTENANCE AND CHECKS BY THE CUSTOMER .....	1-10
	B. Toner Caution .....	1-4	VII.	OPERATION .....	1-11
	C. Ozone Safety .....	1-4	A.	Canon Advanced Printing Technology (CAPT) .....	1-11
IV.	PARTS OF THE PRINTER .....	1-5			
	A. External View .....	1-5			

### CHAPTER 2 OPERATION AND TIMING

I.	BASIC OPERATION .....	2-1	III.	LASER/SCANNER SYSTEM .....	2-17
	A. Functions .....	2-1	A.	Outline .....	2-17
	B. Basic Operation Sequence .....	2-2	B.	Laser Control Circuit .....	2-18
	C. Power-ON Sequence .....	2-3	C.	Scanner System .....	2-21
II.	ENGINE CONTROL SYSTEM .....	2-4	IV.	IMAGE FORMATION SYSTEM .....	2-23
	A. Engine Controller PCB .....	2-4	A.	Outline .....	2-23
	B. Fixing Control Circuit .....	2-8	B.	Print Process .....	2-24
	C. High-Voltage Power Supply Circuit .....	2-10	V.	PICK-UP/FEED SYSTEM .....	2-31
	D. Low-Voltage Power Supply Circuit .....	2-12	A.	Outline .....	2-31
	E. Video Interface .....	2-14	B.	Jam Detection .....	2-33
			VI.	VIDEO CONTROL SYSTEM .....	2-34
			A.	Interface Controller PCB .....	2-34

### CHAPTER 3 THE MECHANICAL SYSTEM

I.	PREFACE .....	3-1	B.	Pickup Roller .....	3-10
II.	EXTERNALS .....	3-2	C.	Separation Pad .....	3-10
	A. Arrangement of the Components .....	3-2	D.	Transfer Charging Roller .....	3-12
	B. External Covers .....	3-2	E.	Pressure Roller .....	3-12
III.	MAIN UNITS .....	3-5	V.	SWITCHES, SENSORS, AND LEDS .....	3-13
	A. Laser/Scanner Unit .....	3-5	A.	Arrangement of the Components .....	3-13
	B. Drive Assembly .....	3-5	B.	Paper Top Sensor/ Paper-out Sensor .....	3-14
	C. Feed Assembly .....	3-6	C.	Power Switch/Test Print Switch/ Door Open Detection Switch/ Paper Delivery Sensor .....	3-14
	D. Delivery Assembly .....	3-7	D.	Indicator LED .....	3-14
	E. Fixing Film Unit .....	3-7			
IV.	MAJOR COMPONENTS .....	3-9			
	A. Arrangement of the Components .....	3-9			

VI. MOTOR/SOLENOID .....	3-15	VII. PCBS .....	3-17
A. Arrangement of the Components	3-15	A. Arrangement of the Components	3-17
B. Main Motor .....	3-16	B. Interface Controller PCB .....	3-18
C. Pick-up Solenoid .....	3-16	C. Engine Controller PCB .....	3-18
		D. Display PCB .....	3-20

## **CHAPTER 4 TROUBLESHOOTING**

I. PREFACE .....	4-1	B. Electrical Adjustment .....	4-21
A. Malfunction Diagnosis		C. LEDs, Test Pins, Jumpers,	
Flowchart.....	4-1	and Switches on PCBs .....	4-22
B. Initial Check.....	4-4	VIII. MAINTENANCE AND	
C. Test Print .....	4-5	SERVICING .....	4-23
II. IMAGE DEFECTS		A. Periodic Replacement	
TROUBLESHOOTING .....	4-7	Parts .....	4-23
III. JAMS TROUBLESHOOTING .....	4-13	B. Expected Servicing Lives of	
IV. TRANSPORT		Consumable Parts .....	4-23
TROUBLESHOOTING .....	4-16	C. Periodic Service .....	4-23
V. MALFUNCTION		D. Cleaning During a Service	
TROUBLESHOOTING .....	4-17	Visit .....	4-24
VI. MALFUNCTION STATUS		E. Standard Tools .....	4-26
TROUBLESHOOTING .....	4-18	F. Special Tools .....	4-27
VII. MEASUREMENT AND		G. List of Lubricants and	
ADJUSTMENT .....	4-21	Cleaners .....	4-27
A. Mechanical Adjustment .....	4-21	IX. LOCATION OF CONNECTORS .....	4-28

## **APPENDIX**

I. GENERAL TIMING CHART .....	A-1	A. Engine Controller PCB .....	A-3
A. Timing Chart for Printing		B. Interface Controller PCB .....	A-3
Two A4-size Sheet		III. LIST OF SIGNALS .....	A-5
Continuously .....	A-1	A. Engine Controller .....	A-5
II. GENERAL CIRCUIT DIAGRAM .....	A-3	IV. MESSAGES TABLE .....	A-7
		A. Message List .....	A-7

# CHAPTER 1

## PRODUCT INFORMATION

I.	FEATURES.....	1-1	V.	INSTALLATION .....	1-7
II.	SPECIFICATIONS .....	1-2	VI.	MAINTENANCE AND CHECKS	
III.	 SAFETY INFORMATION .....	1-4		BY THE CUSTOMER .....	1-10
IV.	PARTS OF THE PRINTER .....	1-5	VII.	OPERATION .....	1-11

## I. FEATURES

### 1. Small-Sized Printer with High Speed and High Resolution

This printer has paper pick-up trays on its top for space saving, and is compact enough to set on a desk. In addition, it has realized high speed of 10 pages per minute (A4) and high resolution of 600 dpi.

### 2. Employment of Canon Advanced Printing Technology

With Canon Advanced Printing Technology, data can be processed within a host computer. This frees the printer from the PDL conversion and image processing, increasing the speed performance and reducing the cost.

### 3. Shortened Wait Time & Low Power Consumption

By adopting an on-demand fixing method that drives the heater only during printing, the printer has shortened the wait time and reduced the consumption power during standby.

### 4. Low Noise

In addition to an on-demand fixing method, the printer has increased its heat exhaust efficiency so as to remove the fan for realizing a low noise level.

### 5. Employment of USB Interface as a Standard

The printer employs an USB interface as a standard, allowing easy connection to peripherals.

## II. SPECIFICATIONS

### A. Printer

#### 1. Printer Engine

1) Type	Desktop page printer
2) Printing method	Electrophotography
3) Printing speed ( <b>Note1</b> )	10 pages/minute (A4)
4) First print time ( <b>Note2</b> )	
Face-down	18 seconds or less
Face-up	17 seconds or less
5) Wait time ( <b>Note3</b> )	8 seconds or less
6) Resolution	
Horizontal	600 dots/inch
Vertical	600 raster lines/inch
7) Image formation system	
Laser	Semiconductor laser
Scanning system	Rotating four-faced prism mirror
Photosensitive drum	OPC
Charging	Roller charging
Exposure	Laser scanning
Toner	Magnetic single-component dry toner
Development	Toner projection development system
Toner supply	Replaceable EP-22 toner cartridge (able to print approx. 2,500 A4-sized print sheets: with image density set in the middle, and 4 % dot density ratio)
Image transfer	Roller transfer
Separation	Curvature separation
Cleaning	Blade
Fixing method	On-demand fixing
8) Feeding	Manual feed slot
	Multi-purpose tray
Paper types	Plain paper, recycled paper, colored paper, labels, OHT, index cards, postcards and envelopes
Paper size ( <b>Note4</b> )	
Manual feed slot	76.2 mm(W) x 127 mm(L) ~ 216 mm(W) x 356 mm(L) sized paper (64 g/m <sup>2</sup> to 105 g/m <sup>2</sup> Canon recommended paper) and above mentioned paper
Multi-purpose tray	76.2 mm(W) x 127 mm(L) ~ 216 mm(W) x 356 mm(L) sized paper (64 g/m <sup>2</sup> to 105 g/m <sup>2</sup> Canon recommended paper) and above mentioned paper
Capacity	
Manual feed slot	one sheet
Multi-purpose	Depth 12.5 mm (Approx. 125 sheets of 64 g/m <sup>2</sup> paper)
9) Delivery ( <b>Note5</b> )	Face-down/face-up
Face-down tray capacity	Approx. 50 sheets of 64 g/m <sup>2</sup> paper
10) Duplex printing	
Manual duplex printing ( <b>Note6</b> )	The paper is picked up from the multi-purpose tray and delivered face-up. Only plain paper (64-105 g/m <sup>2</sup> Canon recommended paper) can be printed duplex.
11) Operating environment	
Temperature	10 to 32.5 °C (50 to 90.5 °F)
Humidity	20 to 80% RH
Air pressure	613 to 1013 hPa (460 to 760 mmHg)

12) Power consumption	110-127Vmodel	220-240Vmodel
Maximum	Approx. 740 W (reference)	Approx. 672 W (reference)
During printing	Approx. 250W (average)	Approx. 250W (average)
During standby	Approx. 5W (average)	Approx. 5W (average)
13) Noise level (Officially announced noise emission level in accordance with ISO 9296)		
Sound power level	6.2 B or less (printing)	
(1B = 10 dB)	Dark sound level (standby)	
Sound pressure level	50 dB or less (printing)	
(Bystander position)	Dark sound level (standby)	
14) Dimensions (Note7)	362 mm(W) x 307 mm(D) x 240 mm(H)	
	14.2 in.(W) x 12.2 in.(D) x 9.5 in.(H)	
15) Weight		
printer only	Approx. 6.0 Kg / 13.2 lb	
cartridge	Approx. 730 g / 1-5/81 lb	
16) Power supply	110-127V ±10% (50/60 Hz ±2 Hz)	
	220-240V +6%-10% (50 Hz ±2 Hz)	

- 
- Notes:**
1. A test print when the room temperature is 20 °C and the rated power voltage is input.
  2. The time taken from that the Print signal is received from the video controller until that an A-4 sized paper is delivered completely, and also when the printer is in the Ready mode at room temperatures of 20 °C.
  3. The time taken from that the power plug is plugged in until that the printer becomes ready to print (Ready or Standby mode.)
  4. Paper with the width of less than 182 mm should not exceed 235 mm in length.
  5. Only plain paper and recycled paper can be delivered face-down.
  6. To print duplex manually, uncurl the face-up delivered paper and set it in the multi-purpose tray.
  7. Without the delivery guide and the paper pickup sub tray.
- 

**2. Interface controller**

1) Printing System	Canon Advanced Printing Technology
2) ROM capacity	8 KB
3) RAM capacity	512 KB
4) Interface	USB(V1.1) interface

Specifications are subject to change with product improvement.

### III. SAFETY INFORMATION

#### A. Handling the Laser/Scanner Unit

An invisible laser beam is emitted within the laser/scanner unit.

The laser beam can cause eye damage if exposed, so be sure not to disassemble the laser/scanner unit. It is not necessary to adjust the laser/scanner unit in this printer in the field.

The following label is attached to the laser/scanner cover.



Figure 1-3-1

#### B. Toner Caution

The toner is non-toxic substance composed of plastics and minute color pigments.

If toner adheres to the skin or clothing, remove as much as possible with dry tissue first, then wash with cold water, Hot water should not be used, as the toner will solidify and become difficult to remove.

Toner will easily decompose vinyl materials, therefore avoid the toner to come close to vinyl.

#### C. Ozone Safety

An infinitesimal amount of ozone gas (O<sup>3</sup>) is generated during corona discharge from the charging roller. The ozone gas is emitted only while the printer is operating.

This printer meets the ozone emission reference value set by Underwriters Laboratory (UL) at the time it is shipped from the factory.

## IV. PARTS OF THE PRINTER

### A. External View

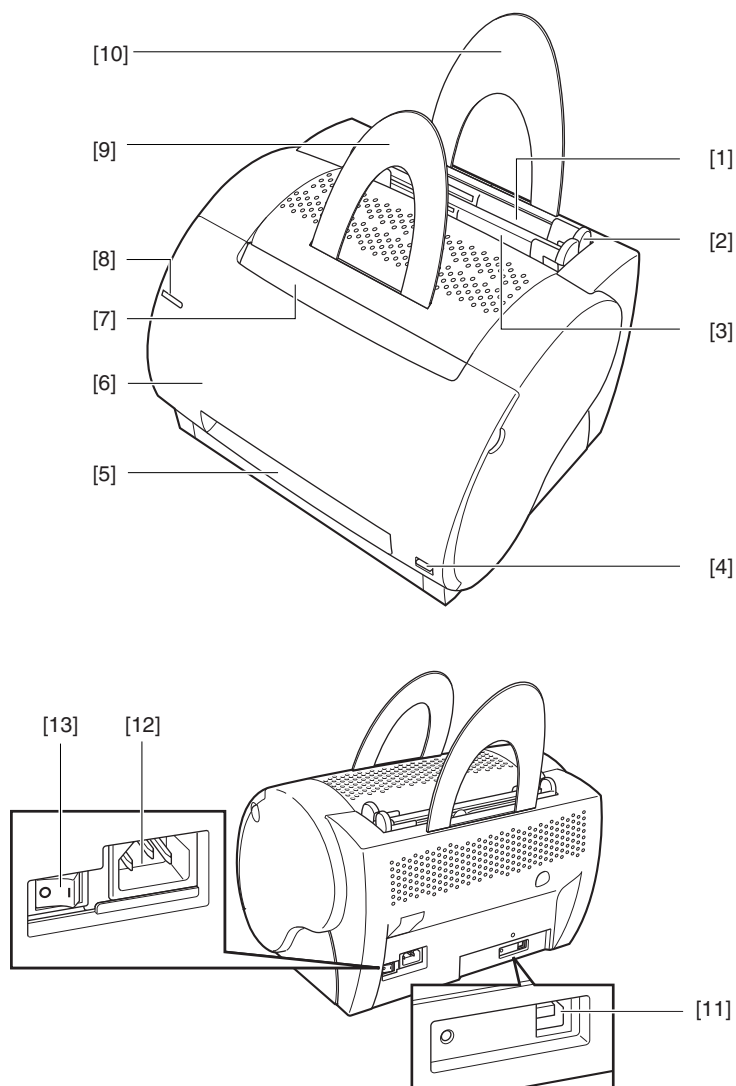

- [1] : Multi-purpose tray
- [3] : Manual feed slot
- [5] : Face-up delivery port
- [7] : Face-down delivery tray
- [9] : Delivery guide
- [11] : USB port
- [13] : Power switch

- [2] : Paper width guide
- [4] : Delivery switching lever
- [6] : Cartridge cover unit
- [8] : Display unit
- [10] : Paper pickup sub tray
- [12] : Power receptacle

Figure 1-4-1

B. Cross Section

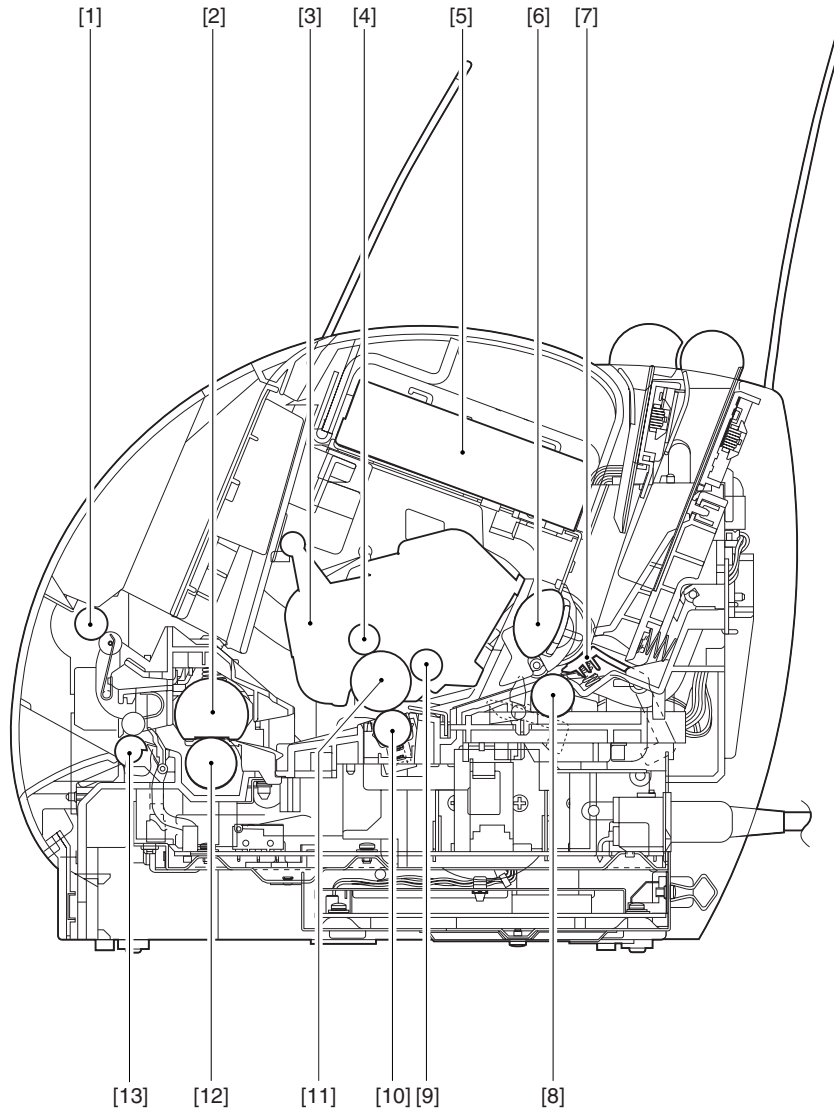

- [1] : Face-down delivery roller
- [3] : EP-22 cartridge
- [5] : Laser/scanner unit
- [7] : Separation pad
- [9] : Developing cylinder
- [11] : Photosensitive drum
- [13] : Fixing delivery roller

- [2] : Fixing film unit
- [4] : Primary charging roller
- [6] : Pick-up roller
- [8] : Feed roller
- [10] : Transfer charging roller
- [12] : Pressure roller

Figure 1-4-2

## V. INSTALLATION

### A. Precautions

This product has been carefully adjusted and strictly inspected before packing and shipping. To make the operation as intended, it is important to install it correctly. Service engineers must understand the performance of the printer sufficiently, install it in the appropriate environment with proper procedures, and operate the necessary checks.

The following requirements must be met when installing the printer.

The service engineer should inspect the installing site before taking the printer to the customer's premises.

- Power must be directly connectable to a single socket with a supply voltage within  $\pm 10\%$  of the rated voltage (110-127V) or  $+6\%$  to  $-10\%$  of the rated voltage (220-240V.)
- The temperatures should be in a range from 10 to 32.5 °C and the relative humidity from 20 to 80 %. Avoid areas closed to water faucets, boilers, humidifiers, or refrigerators.
- Avoid areas near open flames, dusty locations, windy locations, areas which emit ammonia gas, and areas directly exposed to sunlight. When exposure to direct sunlight is unavoidable, hanging curtains is recommended.
- The room should be well ventilated.
- The printer should be placed on a level surface.
- If the printer is set up on a desk, be sure a study desk is used.
- Set the printer at a suitable distance from the wall for easy operation (See Figure 1-5-1.)  
There must be enough space around the printer to operate.

Following dimensions should be taken into consideration to select an installation space for the printer.

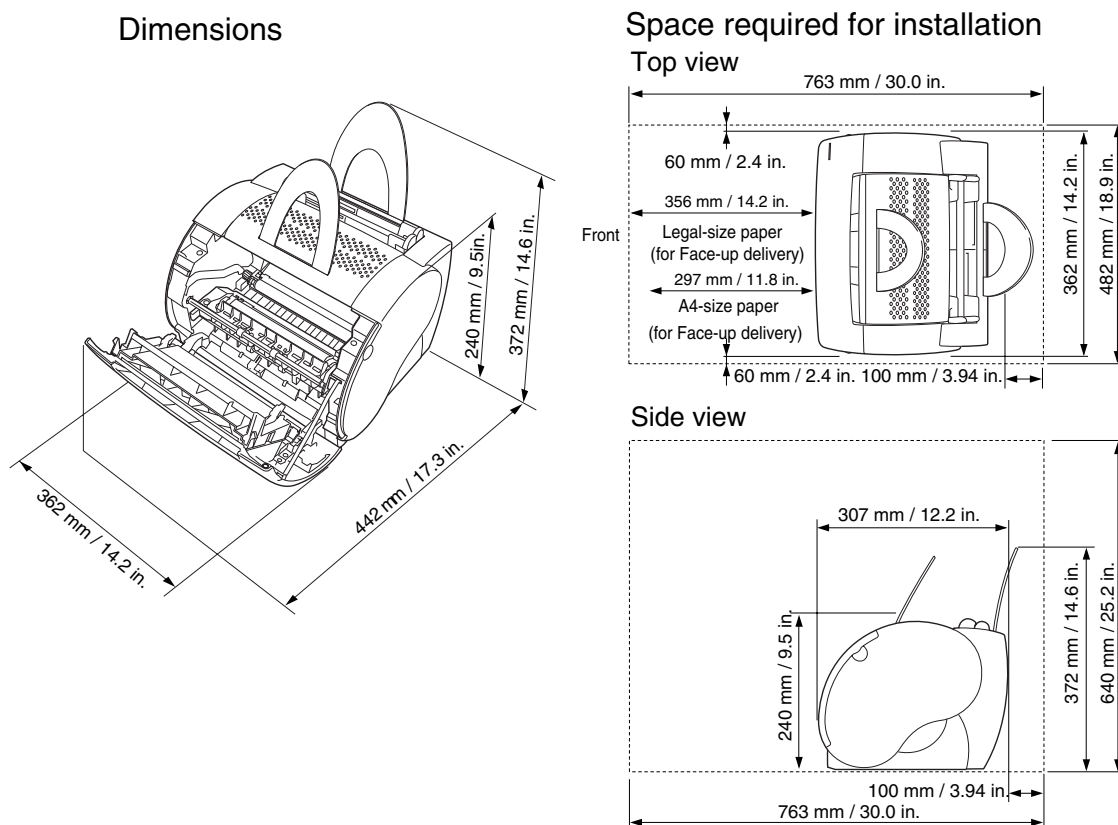

Figure 1-5-1

When metals are moved from a cold area to warm area, condensation may appear. This can lead to various troubles during an operation. When the printer needs to be moved from a cold area to warm area, leave it packed in its box for at least an hour to acclimatize to room temperature.

**B. Storage and Handling of EP-22 Cartridge**

As time passes, the natural environment will change the cartridge, whether sealed or installed in the printer, or regardless of the number of prints. The progression of this natural change depends largely on the storage and installation environment, therefore, take special care on storage and handling the cartridge.

**a. Storage of Sealed EP-22 Cartridge Package**

When storing EP-22 cartridge in warehouses or workshops, be sure that they are kept within humidity/storage conditions range shown in Table 1-5-1.

Also note the following:

- 1) Avoid areas exposed to direct sunlight.
- 2) Do not place them in locations which are subject to severe vibration.
- 3) Do not bump or drop the cartridge.
- 4) Avoid high temperature environment, keep EP-22 cartridge below 35 °C.

**Table 1-5-1**

Temperature	Normal (total storage time X 9/10)	0 to 35°C	
	Severe (total storage time X 1/10)	High	35 to 40°C
		Low	-20 to 00°C
Temperature change (within 3 minutes or so)		400°C → 15°C -20°C → 250°C	
Relative humidity	Normal (total storage time X 9/10)	35 to 85% RH	
	Severe (total storage time X 1/10)	High	85 to 95% RH
		Low	10 to 35% RH
Air pressure		613 to 1013hPa (460 to 760 mmHg)	

---

**Note:** Total storage time is the valid time span following the manufacture date displayed on the cartridge box.

---

**b. Storage of Unsealed EP-22 Cartridge**

Since an organic photoconductor (OPC) is used for the photosensitive drum, intensive light will damage the drum. Since toner is contained in the cartridge, it is necessary to thoroughly explain the various storage and handling procedures of unsealed cartridges to customers.

Also, note the following:

- 1) Avoid areas which are exposed to direct sunlight such as near windows. Avoid leaving the packages in cars for an extended period of time as high temperatures can damage them.
- 2) Avoid high temperature and high humidity, and low temperature and low humidity environment. Avoid areas where the temperature or humidity drastically change such as a location near air conditioners.
- 3) Avoid dusty areas or locations which emit ammonia or organic solvent gases.
- 4) Keep EP-22 cartridge below 35 °C
- 5) Avoid placing the package near CRT displays, disk drive units, or floppy disks.

**c. Notes on Handling of Cartridge**

- 1) Before installing a new EP-22 cartridge in the printer, hold the cartridge at both sides as shown below, and gently slop it at about 45 ° right-up and left-up 5 or 6 times to distribute toner evenly. Do not rock the cartridge in any other way, as the toner may leak from the developing unit or cleaner unit.

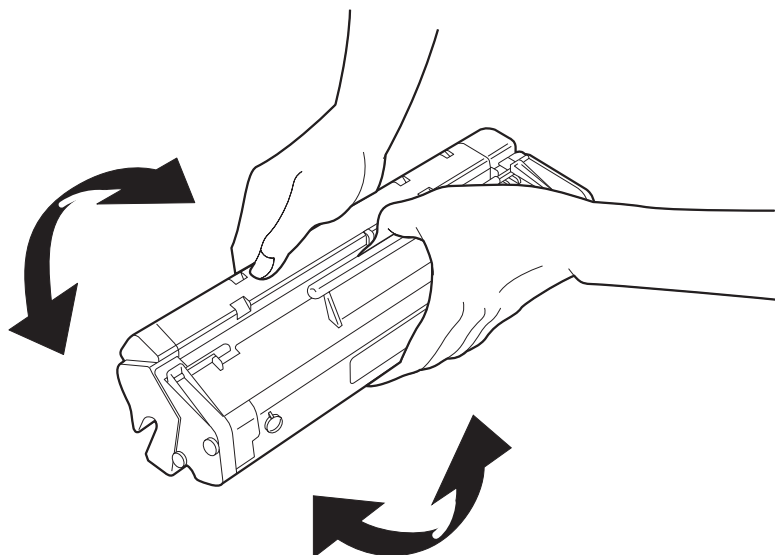
**Figure 1-5-2**

Print the test pattern of 3 to 5 sheets to ensure that output images are not spoiled by a toner leak after installing the cartridge in the printer.

- 2) If blank spots appear on the output image due to an uneven distribution of toner in the cartridge, shake the cartridge to evenly distribute as shown in 1).
- 3) Do not place the cartridge on its end or upside down.
- 4) Do not open the protective shutter of the photosensitive drum and never touch the drum surface. Do not clean the photosensitive drum.
- 5) Do not disassemble EP-22 cartridge.
- 6) Do not give vibration or shock to the cartridge.
- 7) Intensive light easily damages the photosensitive drum, causing blank spots or black stripes on the printed image. Faulty print images can be corrected by stopping the printer momentarily. However, if the drum is exposed too long, the blank spots and black stripes may remain even after stopping the printer. To prevent this, be sure to always place the unsealed cartridges in their boxes or under a cover. Do not leave them uncovered after removing from the printer.

---

**Reference:** If the cartridge are exposed to ordinary light for five minutes and then left in a dark area for another five minutes, the print quality will return to a virtually permissible level. However, do not expose the cartridge to direct sunlight.

---

**VI. MAINTENANCE AND CHECKS BY THE CUSTOMER**

The table below lists the maintenance points that should be performed by the customer to maintain the printer at optimum level.

**Table 1-6-1**

Item	Customer maintenance
Cartridge	Shake or replace the cartridge as necessary.
External Cover	Clean the external cover as necessary.

## VII. OPERATION

### A. Canon Advanced Printing Technology (CAPT)

Canon Advanced Printing Technology (hereafter referred to as CAPT) reduces the processing time and simplifies the operations for printing in the Microsoft Windows environment.

The easy operations and speedy printing are supported by the following features of CAPT:

- Instead of converting print data sent from application into the printer's page description language (PDL), CAPT translates the print data into resource data compatible to the graphic drawing system commands (GDI data.)
- The resource data compatible to the GDI data is developed to dot data, and then passed to a host computer.
- The printing environment can be set in the dialog box on the host computer screen.
- The printer status is shown on the host computer screen, so users can view and confirm the print time, print paper status, error conditions, and etc..

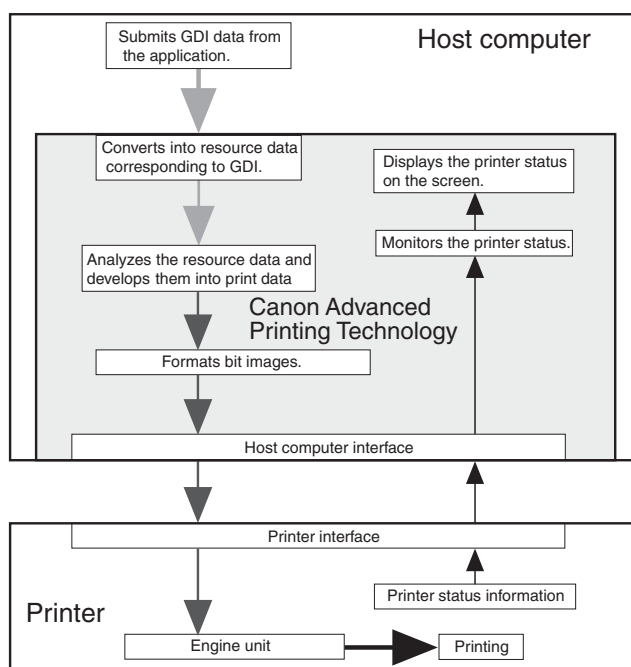

Figure 1-7-1

**Note:** GDI : Graphic Device Interface

A graphic drawing system that performs printing and displaying in the Windows environment, (and a graphic drawing system interface with the application.)



CAPT operates on Microsoft Windows 98/Me/2000/XP. The installation is done using the Canon Advanced Printing Technology disk included with this printer.

CAPT specifies paper sizes, document sizes, number of copies, and print quality on the computer screen. The operation methods of the dialog boxes vary in Microsoft Windows 98/Me/2000/XP.

Refer to the users guides for the installation procedures and operations.

# CHAPTER 2

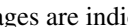
## OPERATION AND TIMING

This chapter describes the printer functions, the relationships between mechanisms and circuits, and the timing of operations. Mechanical linkages are indicated by black and white lines (  ), the flow of control signals by solid arrows (  ), and the flow of groups of signals by outline arrows (  ).

There is a microcomputer in this printer. But as the internal operation of the microcomputer cannot be checked, an explanation of the operation of the microcomputer has been left out.

As it is assumed that no repair will be made to customer circuit boards, the explanation of board circuits is limited to an outline using block diagrams. So there are two types of circuit explanations; (1) everything from the sensor to the input sections of the major circuit boards, (2) everything from the output sections of the major circuit boards to the loads. These are explained with block diagrams according to the function.

I. BASIC OPERATION .....	2-1	IV. IMAGE FORMATION SYSTEM .....	2-23
II. ENGINE CONTROL SYSTEM .....	2-4	V. PICK-UP/FEED SYSTEM .....	2-31
III. LASER/SCANNER SYSTEM .....	2-17	VI. VIDEO CONTROL SYSTEM .....	2-34

# I. BASIC OPERATION

## A. Functions

Printer functions can be divided into five groups: video control system, engine control system, image formation system, laser/scanner system, and paper pickup/feed system.

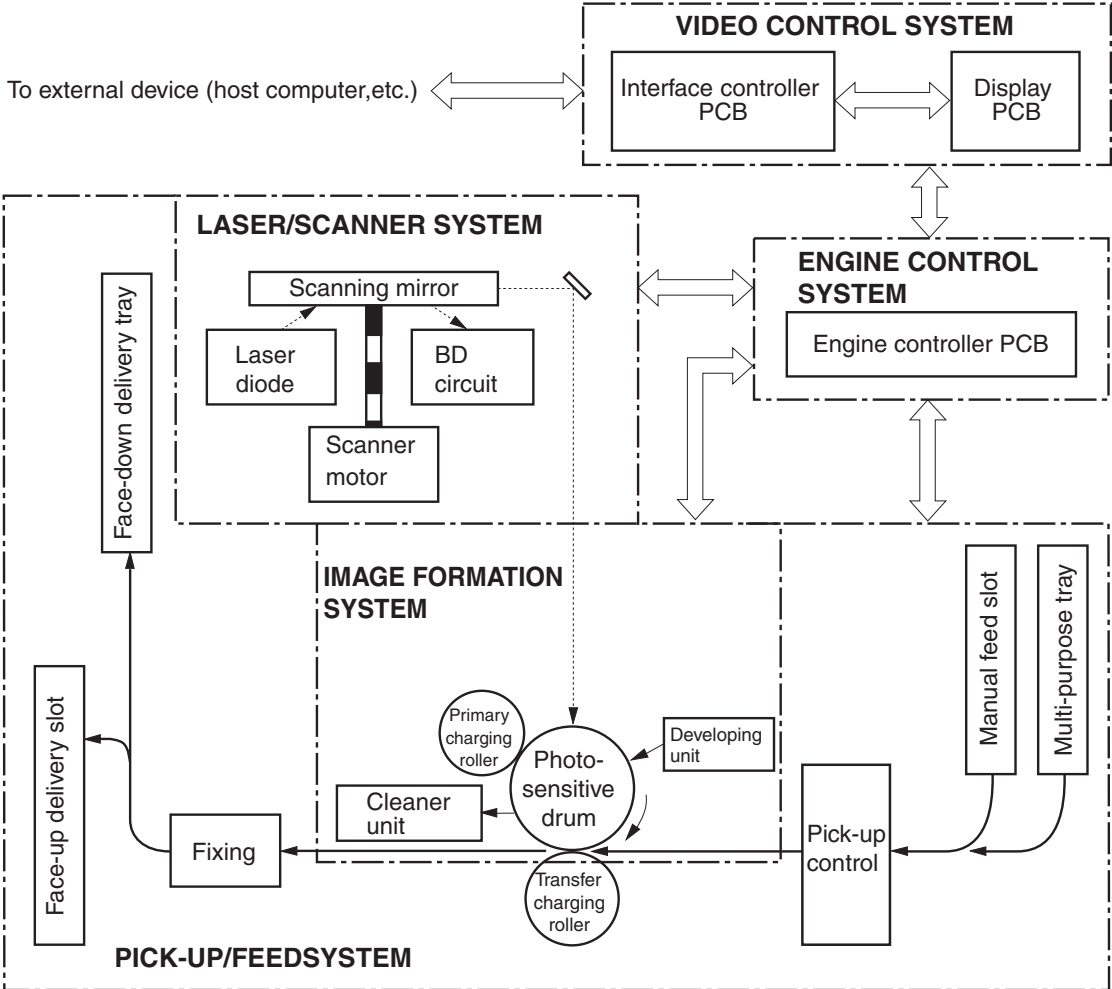

Figure 2-1-1

**B. Basic Operation Sequence**

The operation sequence of this printer is controlled by the microcomputer on the engine controller PCB. The table describes the purpose of each period from the time the printer is turned ON until the main motor stops rotating after the completion of printing. Refer to the APPENDIX for the detailed timing chart.

**Table 2-1-1**

Period		Purpose	Remarks
WAIT (WAIT period)	From power-ON until the end of the main motor initial rotation.	To clear the drum surface of potential and to clean the transfer charging roller.	Detects whether the cartridge is installed or not.
STBY (STANDBY)	From the end of the WAIT period or the LSTR period until the input of the pick-up command from the interface controller.Or,from the end of the LSTR period until power-OFF.	To keep the printer ready to print.	
INTR (INITIAL ROTATION period)	From the input of the pick-up command from the interface controller until the paper reaches the paper top sensor.	To stabilize the photosensitive drum sensitivity in preparation for printing. Also to clean the transfer charging roller.	
PRINT (Print)	From the end of the initial rotation until the primary voltage going OFF.	To form images on the photosensitive drum based on the VIDEO signals (/VDO,VDO) input from the interface controller and to transfer the toner image on to the paper.	
LSTR (LAST ROTATION period)	From the time the primary voltage goes OFF until the main motor discontinues rotating.	To deliver the last page. Also to clean the transfer charging roller.	If the pick-up command is input from the interface controller, the printer enters the INTR period immediately after the end of the LSTR period.

**C. Power-ON Sequence**

The following explains the sequence from power-ON until the printer enters the STANDBY mode.

- 1) Power-ON.
- 2) CPU initialization.
- 3) The video interface communication start.  
After 0.5 seconds from the time the status command signal (/SC) turns "H", the video interface becomes ready to communicate.
- 4) Paper jam detection and door open detection.  
Detects the sensors for the presence of paper and door open.
- 5) Fixing unit ON  
Drives the fixing unit for 0.5 seconds. Stops driving if the fixing unit temperature is 100°C or more.
- 6) Scanner motor initial rotation.
- 7) Main motor initial rotation.
- 8) High-voltage control.  
Detects the presence of the cartridge after the primary high-voltage goes ON. Also, cleans the transfer charging roller.
- 9) Failure/abnormality check  
Detects the scanner and fixing unit failures.

## II. ENGINE CONTROL SYSTEM

### A. Engine Controller PCB

#### 1. Outline

The operation sequence of the printer is controlled by the CPU on the engine controller PCB. When the printer is turned ON and enters the STANDBY mode, the CPU outputs signals to drive loads, such as the laser diode, motors, and solenoids, based on the pickup command and image data input from the interface controller.

A block diagram of this circuit is shown below.

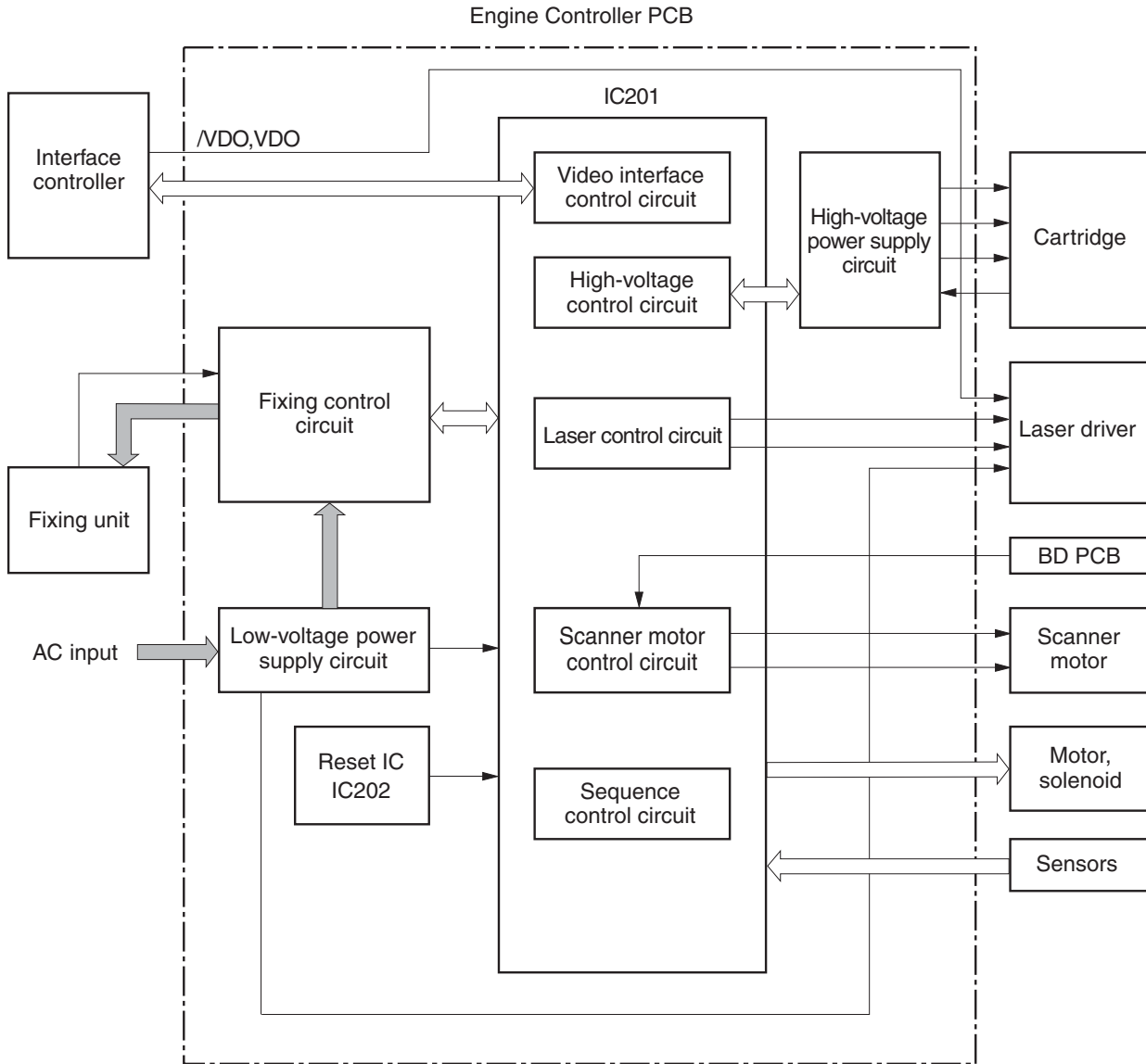

Figure 2-2-1

**2. Operations****a. CPU (IC201)**

This printer contains an 8-bit single-chip microcomputer for its CPU.

This CPU is a single-chip CPU with a built-in ROM and RAM. It performs the controls for the following items based on the control program stored in the ROM.

- 1) Printer sequence.
- 2) Video interface.
- 3) High-voltage power supply circuit.
- 4) Laser/scanner.
- 5) Sensors.
- 6) Loads (motors, solenoids, etc.).

**b. Reset IC (IC202)**

IC202 monitors +3.3V and resets the CPU when the power is turned ON.

**c. Fixing Control Circuit**

See the section “B. Fixing Control Circuit” in this chapter.

**d. High-Voltage Power Supply Circuit**

See the section “C. High-Voltage Power Supply Circuit” in this chapter.

**e. Low-Voltage Power Supply Circuit**

See the section “D. Low-Voltage Power Supply Circuit” in this chapter.

3. Engine Controller Input and Output

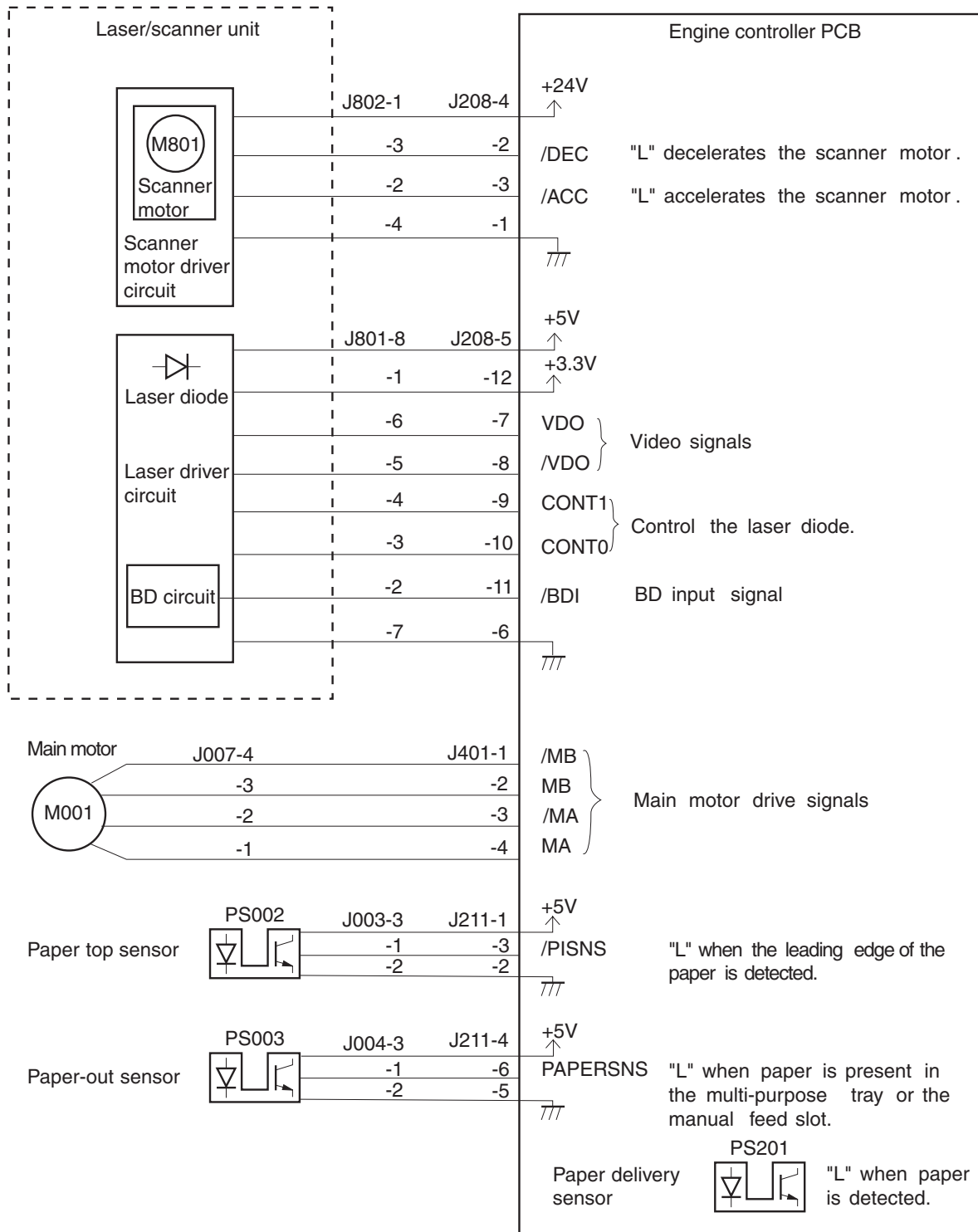

Figure 2-2-2

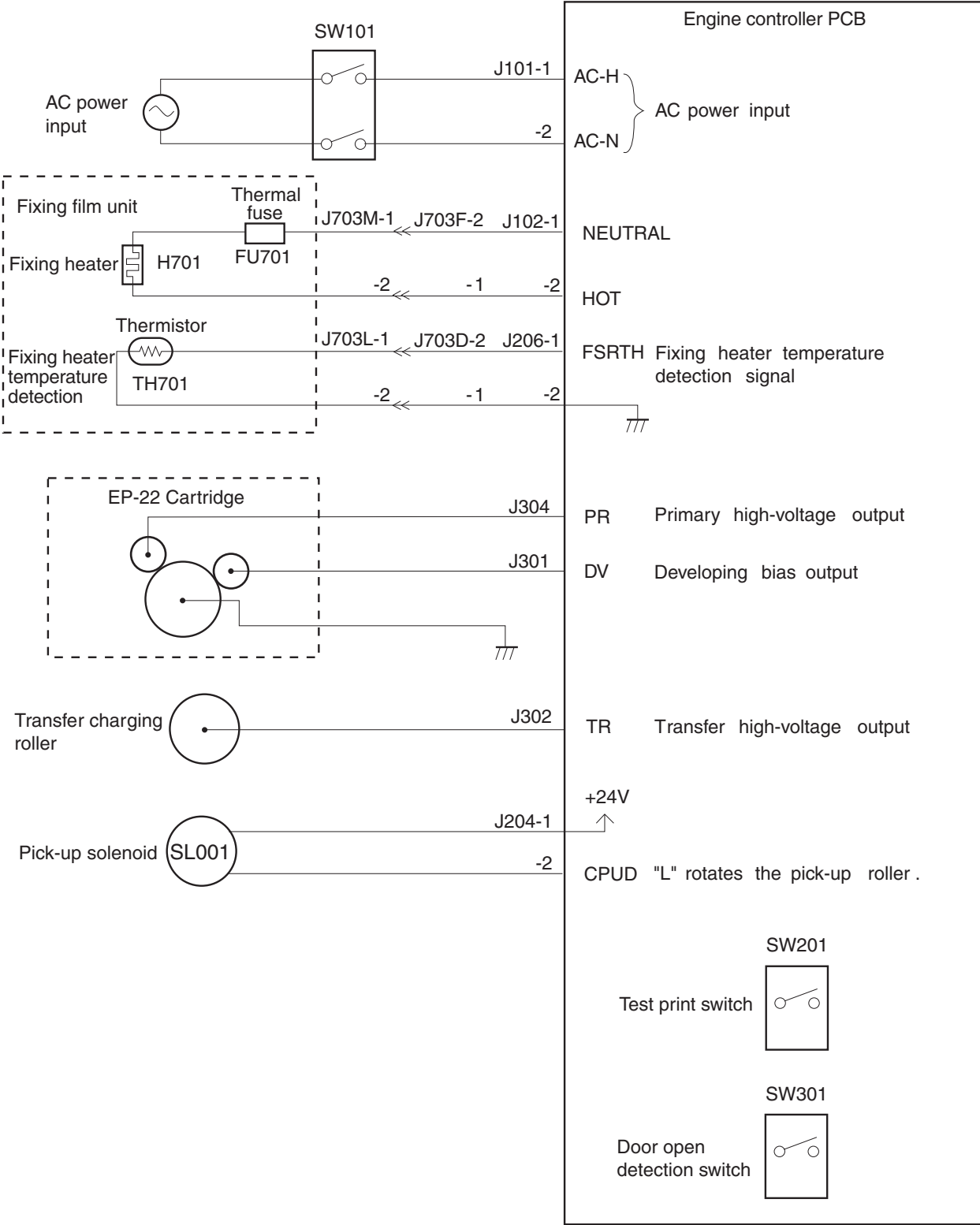

Figure 2-2-3

**B. Fixing Control Circuit**

**1. Fixing Temperature Control**

The fixing film unit of the printer contains a plate-shaped fixing heater to heat up the fixing film.

The fixing heater temperature is detected by the thermistor (TH701) on the fixing heater. When the temperature rises, the resistance of TH701 drops and the voltage of the FIXING HEATER TEMPERATURE DETECTION signal (FSRTH) decreases.

The CPU (IC201) on the engine controller PCB outputs the FIXING HEATER DRIVE signal (FSRD) based on the FSRTH signal voltage to bring the fixing heater temperature to the specified value.

The fixing heater temperature is controlled by the following three modes:

- 1) Initial temperature control: Increases to the normal target temperature after the pickup command is input to the engine controller.
- 2) Normal temperature control: Maintains the normal target temperature (about 190°C) during printing.
- 3) Between-page temperature control: Controls at low temperature in order to prevent the temperature rise at the non-feeding areas between pages on the fixing film.

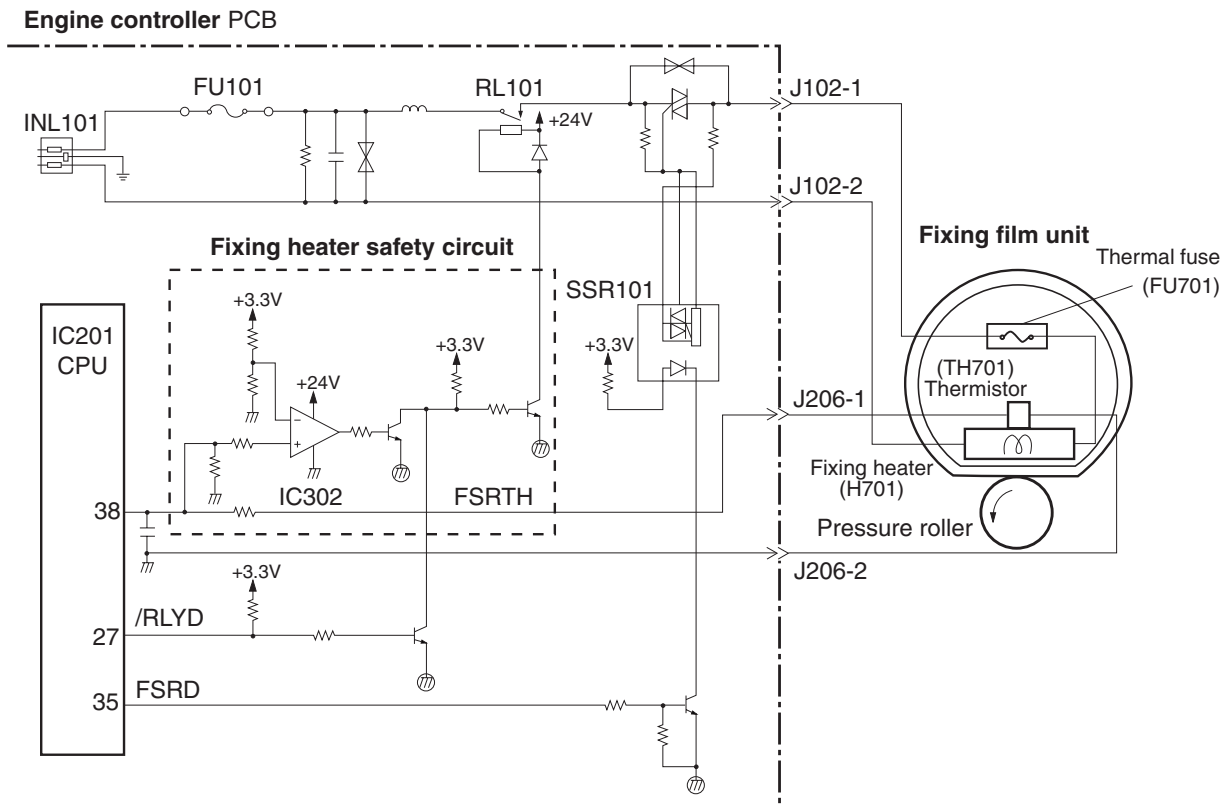

Figure 2-2-4

**2. Fixing Heater Safety Circuit**

This circuit is installed on the engine controller PCB and always monitors the abnormal rise of the fixing temperature.

When the output voltage from the thermistor falls below about 0.67V (244°C) due to the elevation of the fixing heater temperature, the output of the comparator (IC302) becomes “L” and the relay (RL101) goes OFF, cutting off power to the fixing heater.

### 3. Protection function

The printer contains the following three protective functions in order to prevent excursion of the fixing heater.

- ◆ The CPU monitors the voltage of TH701. When detecting an abnormality, the CPU assesses a fixing heater failure and sets the FIXING HEATER DRIVE signal (FSRD) to “L” and the /RLYD signal to “H” as to turn OFF the relay (RL101), shutting off power to the fixing heater. At the same time, the CPU notifies the failure to the interface controller.
- ◆ When the fixing heater temperature rises abnormally and the thermal fuse exceeds 228°C, the thermal fuse melts, cutting off the power supply to the fixing heater.
- ◆ When the fixing temperature rises abnormally and the voltage of TH701 falls below about 0.67V (244°C equivalent), the fixing heater safety circuit interrupts the power supply to the fixing heater regardless of the output from the CPU.

### 4. Detecting Fixing Heater Error

The CPU assesses fixing heater failures and notifies the failure to the interface controller under the following conditions:

- a. Within 500 msec after the start of the initial temperature control, the temperature does not reach 20°C.
- b. During the fixing heater temperature control, the temperature remains above 250°C for more than the specified period of time.
- c. During the print or warm-up period, the temperature does not reach 100°C, even though the power has been supplied for the specified period of time.
- d. After the 500-msec fixing heater temperature control at the powering-ON, the CPU starts the normal temperature control and monitors the temperature every 135 msec. During this normal temperature control, the temperature sequentially drops to less than 20°C twice.
- e. During the normal temperature control, the fixing heater temperature falls below 100°C for the specified period of time.

---

**Note:** The fixing film may be damaged if rotated at a temperature of 100°C or below due to the high oil viscosity. Therefore, the fixing heater is required to rise above 100°C as to melt the oil before rotated.

---

When determining a fixing unit failure, the CPU performs the following operations:

- 1) Cuts off the power supply to the fixing heater.
- 2) Turns off the relay.
- 3) Immediately stops driving the main motor, scanner motor, and high-voltage system and sets the printer to the error mode regardless of the presence of ongoing paper.

### 5. Pressure Roller Dirt Prevention Function

This function prevents toner from adhering to the pressure roller and building up on it.

As the temperature goes down after the completion of printing, the toner remaining on the nip adheres to the pressure roller. As the time goes by, the toner develops gradually to form a lump. The lump sticks to the fixing film, causing the paper to be dirty. To prevent this, the CPU performs the following operation:

- 1) After the printing is completed and the main motor stops, the CPU heats up the fixing heater with high temperature for five seconds.
- 2) When detecting that the thermistor drops to the specified temperature, the CPU drives the main motor for 500 msec to move the nip location.

C. High-Voltage Power Supply Circuit  
 1. Outline

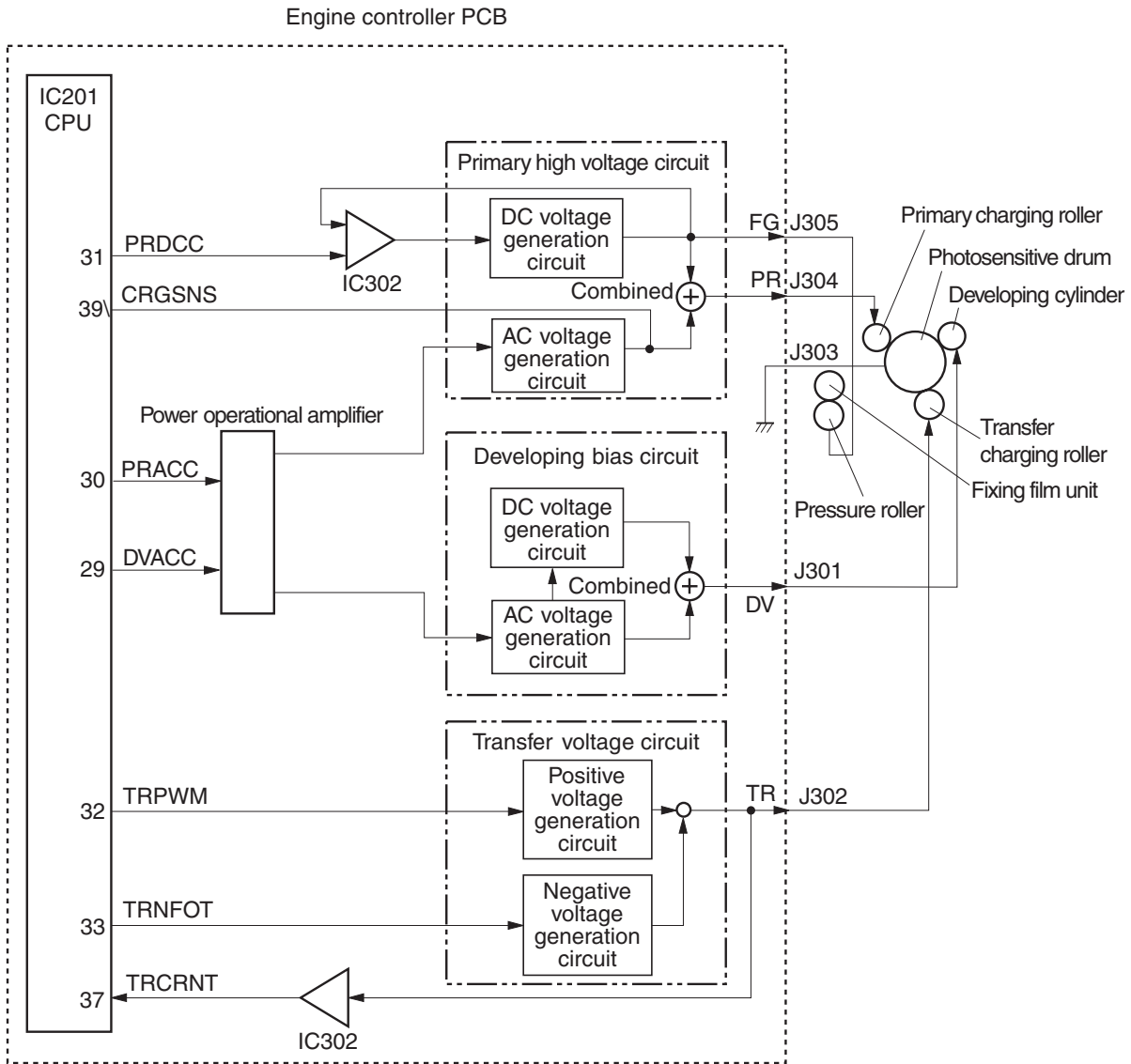

Figure 2-2-5

This circuit applies the combined voltage of the DC voltage and AC voltage to the primary charging roller and developing cylinder, and also applies the positive or negative DC voltage to the transfer charging roller, according to the instructions sent from the microcomputer (CPU) on the engine controller.

The circuit adjusts the image density by changing the primary high-voltage (DC) and the developing bias according to the image density data sent from the interface controller.

## 2. Operation

### a. Primary Charging Roller Voltage Generation

When the pickup command is sent from the interface controller, the INITIAL ROTATION period (INTR) starts, and the PRIMARY HIGH VOLTAGE (AC) DRIVE signal (PRACC) is input to the primary high-voltage circuit via the power operational amplifier. Meanwhile, the PRIMARY HIGH-VOLTAGE (DC) DRIVE signal (PRDCC) is output from the CPU and input to the primary high-voltage circuit. This generates and combines AC bias and DC bias. The combined primary high-voltage is applied to the primary charging roller.

The IC302 compares the primary high-voltage (DC) with the PRIMARY HIGH-VOLTAGE (DC) DRIVE signal (PRDCC) sent from the CPU in order to control the primary high voltage (DC).

The presence of the cartridge is detected by the CPU. If the CPU detects the current flow (CRGSNS) on the J304, it determines the presence of the cartridge.

### b. Developing Bias Generation

The DEVELOPING BIAS (AC) DRIVE signal (DVACC) is input to the developing bias circuit via the power operational amplifier, causing the circuit to generate the AC bias. Meanwhile, the developing DC bias is generated in the DC generation circuit on the developing bias circuit. The AC bias and DC bias are combined and applied to the developing cylinder.

### c. Transfer Charging Roller Voltage Generation

The transfer charging roller is applied with the negative bias, print bias, and between-page bias according to the print sequence.

The negative bias (negative voltage) cleans the roller by moving the toner adhering to the roller to the photosensitive drum. A negative voltage is applied to the roller at the specified timing.

The print bias (positive voltage) transfers the toner on the photosensitive drum onto the paper. A voltage is applied to the roller.

The between-page bias prevents the residual toner on the photosensitive drum from adhering to the transfer charging roller. A positive voltage lower than the print bias is applied to the roller at the specified timing.

When the interface controller outputs a pickup command, the INITIAL ROTATION period (INTR) starts. At the same time, the CPU outputs the TRANSFER NEGATIVE VOLTAGE DRIVE signal (TRNFOT). This applies negative bias to the transfer charging roller for the specified period of time as to clean the roller.

During the print sequence, the CPU outputs the TRANSFER POSITIVE VOLTAGE DRIVE signal (TRPWM) in order to apply the print bias and between-page bias to the transfer roller.

After printing is completed, the negative bias is applied again to clean the transfer charging roller.

### d. Fixing Bias Generation

The CPU outputs the PRIMARY HIGH-VOLTAGE (DC) DRIVE signal (PRDCC), causing the DC generation circuit on the primary high-voltage circuit to output the primary DC bias. The negative DC voltage is applied to the pressure roller as the fixing bias.

### e. Cartridge Detection

When the PRIMARY HIGH-VOLTAGE (AC) DRIVE signal (PRACC) is output from the CPU and then the primary AC bias is output from the AC generation circuit on the primary high-voltage circuit, the primary high-voltage circuit feeds back the CARTRIDGE DETECTION signal (CRGSNS) to the CPU.

During WAIT period, the CPU checks the voltage of the CRGSNS signal at the timing the primary AC bias is output, in order to detect the presence or absence of the cartridge.