

Product: 2001 Canon iR2200/iR2800/iR3300 Printer Service Repair Workshop Manual
Full Download: <https://www.arepairmanual.com/downloads/2001-canon-ir2200ir2800ir3300-printer-service-repair-workshop-manual/>

iR2200/iR2800/ iR3300 SERVICE MANUAL

REVISION 0

Canon

MAR. 2001

FY8-13H8-000

Sample manual. Download All pages at:

<https://www.arepairmanual.com/downloads/2001-canon-ir2200ir2800ir3300-printer-service-repair-workshop-manual/>
COPYRIGHT© 2001 CANON INC. CANON iR2200/iR2800/iR3300 REV.0 MAR. 2001 PRINTED IN JAPAN (IMPRIME AU JAPON)

Application

This manual has been issued by Canon Inc. for qualified persons to learn technical theory, installation, maintenance, and repair of products. This manual covers all localities where the products are sold. For this reason, there may be information in this manual that does not apply to your locality.

Corrections

This manual may contain technical inaccuracies or typographical errors due to improvements or changes in products. When changes occur in applicable products or in the contents of this manual, Canon will release technical information as the need arises. In the event of major changes in the contents of this manual over a long or short period, Canon will issue a new edition of this manual.

The following paragraph does not apply to any countries where such provisions are inconsistent with local law.

Trademarks

The product names and company names used in this manual are the registered trademarks of the individual companies.

Copyright

This manual is copyrighted with all rights reserved. Under the copyright laws, this manual may not be copied, reproduced or translated into another language, in whole or in part, without the written consent of Canon Inc.

COPYRIGHT © 2001 CANON INC.

Printed in Japan











Imprimé au Japon

Caution

Use of this manual should be strictly supervised to avoid disclosure of confidential information.

1 Symbols Used

This documentation uses the following symbols to indicate special information:

Symbol	Description
	Indicates an item of a non-specific nature, possibly classified as Note, Caution, or Warning.
	Indicates an item requiring care to avoid electric shocks.
	Indicates an item requiring care to avoid combustion (fire).
	Indicates an item prohibiting disassembly to avoid electric shocks or problems.
	Indicates an item requiring disconnection of the power plug from the electric outlet.
 Memo	Indicates an item intended to provide notes assisting the understanding of the topic in question.
 REF.	Indicates an item of reference assisting the understanding of the topic in question.
	Provides a description of a service mode.
	Provides a description of the nature of an error indication.
	Refers to the Copier Basics Series for a better understanding of the contents.

2 Outline of the Manual

This Service Manual contains basic information needed to service the iR2200/iR2800/iR3300 and its accessories (i.e., side paper deck, shift tray) in the field, conducted for the purpose of maintaining its product quality and a specific level of performance. A separate Service Manual is made available for each of its accessories (except for the side paper deck and shift tray); for details, refer to the appropriate manual.

This Service Manual consists of the following chapters:

1. System Unit

Chapter 1	General Description:	features, specifications, names of parts, functions, operation, system configuration, routine maintenance by the user
Chapter 2	Main Controller:	functional construction, outline of electrical circuitry, principles of operation of the image processing system, power supply
Chapter 3	Installation:	site conditions and installation procedure, relocation of the machine, installation of accessories

2. Reader Unit

Chapter 1	Basic Operation:	functional construction, outline of electrical circuitry, basic sequence of operations
Chapter 2	Original Exposure System:	principles of operation of the exposure system, timing of operation, disassembly/assembly and adjustment
Chapter 3	Image Processing System:	principles of operation of the image processing system, timing of operation, disassembly/assembly and adjustment

3. Printer Unit

Chapter 1	Introduction:	safety of the laser, image formation, auxiliary processes
Chapter 2	Sequence of Operations:	basic operations, outline of electrical circuitry, basic sequence of operations
Chapter 3	Laser Exposure System:	principles of operation of the laser exposure system, timing of operation, disassembly/assembly and adjustment
Chapter 4	Image Formation System:	principles of operation of the image formation system, timing of operation, disassembly/assembly and adjustment
Chapter 5	Pickup/Feeding System:	principles of operation of the pickup/feeding system, timing of operation, disassembly/assembly and adjustment



Chapter 6	Fixing System:	principles of operation of the fixing system, timing of operation, and disassembly/assembly and adjustment
Chapter 7	Externals and Controls:	principles of operation of the externals/controls, timing of operation, disassembly/assembly and adjustment
Chapter 8	Paper Deck-L1:	principles of operation, timing of operation, disassembly/assembly and adjustment
Chapter 9	Cassette Feeding Unit-W1:	principles of operation, timing of operation, disassembly/assembly adjustment
Chapter 10	Inner 2Way Tray-A1:	principles of operation, timing of operation, disassembly/assembly adjustment
Chapter 11	Envelope Feeder Attachment-B1:	principles of operation, timing of operation, disassembly/assembly adjustment
4. Troubleshooting		
Chapter 1	Maintenance and Inspection:	table of periodically replaced parts, table of consumables/durables, scheduled servicing chart
Chapter 2	Image Adjustment Basic Procedure:	basic procedure for image adjustment
Chapter 3	Standards and Adjustments:	standards and adjustments
Chapter 4	Troubleshooting Image Faults/Malfunctions:	troubleshooting image faults/malfunctions
Chapter 5	Service Mode:	how to use service mode, list of service modes
Chapter 6	Self Diagnosis:	codes, causes of errors
Chapter 7	Upgrading:	how to upgrade
Appendix:		general timing chart, general circuit diagrams

The descriptions are updated from time to time to reflect product improvements, and major changes are communicated in the form of Service Information bulletins.

All service persons are expected to familiarize themselves with the contents of this Service Manual and Service Information bulletins and acquire a level of knowledge and skill required to promptly respond to the needs of the field.

The following rules apply throughout this Service Manual:

1. Each chapter contains sections explaining the purpose of specific functions and the relationship between electrical and mechanical systems with reference to the timing of operation.

In the diagrams,  represents the path of mechanical drive; where a signal name accompanies the symbol , the arrow indicates the direction of the electric signal.

The expression “turn on the power” means flipping on the power switch, closing the front door, and closing the delivery unit door, which results in supplying the machine with power.

2. In the digital circuits, ‘1’ is used to indicate that the voltage level of a given signal is “High,” while ‘0’ is used to indicate “Low.” (The voltage value, however, differs from circuit to circuit.) In addition, the asterisk (*) as in “DRMD*” indicates that the DRMD signal goes on when ‘0’.

In practically all cases, the internal mechanisms of a microprocessor cannot be checked in the field. Therefore, the operations of the microprocessors used in the machines are not discussed: they are explained in terms of from sensors to the input of the DC controller PCB and from the output of the DC controller PCB to the loads.

The descriptions in this Service Manual are subject to change without notice for product improvement or other purposes, and major changes will be communicated in the form of Service Information bulletins.

All service persons are expected to have a good understanding of the contents of this Service Manual and all relevant Service Information bulletins and be able to identify and isolate faults in the machine.

SYSTEM UNIT SERVICE MANUAL

Contents

CHAPTER 1 GENERAL DESCRIPTION

1	Specifications	1-1S	3.2	Outline of the Electrical Circuitry	1-14S
1.1	Main Body	1-1S	3.2.1	Construction of the Electrical Circuit	1-14S
1.1.1	Type	1-1S	3.3	Inputs to and Outputs from the Major PCBs	1-15S
1.1.2	Systems	1-1S	3.3.1	Wiring Diagram of the Major PCBs	1-15S
1.1.3	Functions	1-2S	3.4	Configuration with Accessories	1-16S
1.1.4	Others	1-5S	3.4.1	Accessories for Original/ Paper Feeding	1-16S
1.2	Side Paper Deck-L1	1-8S	3.4.2	Accessory Boards	1-17S
2	Names of Parts	1-9S			
2.1	External View	1-9S			
2.2	Cross Section	1-11S			
3	System Configuration	1-13S			
3.1	Functional Construction	1-13S			

CHAPTER 2 MAIN CONTROLLER

1	Basic Construction	2-1S	2.2.6	Binary Processing (error diffusion method T-BIC)	2-9S
1.1	Functional Construction	2-1S	2.2.7	Binary (dither screen method)	2-9S
1.2	Outline of the Electrical Circuitry	2-2S	2.3	Image Memory Control	2-9S
1.2.1	Outline	2-2S	2.3.1	Compression/De-Compression, Rotation, and Enlargement/ Reduction	2-9S
1.2.2	Main Controller PCB	2-2S	2.3.2	SDRAM	2-9S
1.2.3	HDD	2-2S	2.3.3	HDD	2-9S
1.3	Start-Up Sequence	2-4S	2.4	Output Image Processing	2-10S
1.3.1	Outline	2-4S	2.4.1	Smoothing	2-10S
1.3.2	Start-Up Sequence	2-5S	2.4.2	Binary-Binary Density Conversion (read image output only)	2-10S
2	Digital Image Processing	2-7S	3	Soft Counters	2-11S
2.1	Outline	2-7S	4	Controlling the Power Supply	2-15S
2.2	Input Image Processing	2-8S	4.1	Outline	2-15S
2.2.1	Image Data from the Reader Unit	2-8S	4.2	Power Supply Modes	2-15S
2.2.2	Enlargement/Reduction (main scanning direction) ...	2-8S	4.3	Standby Mode (normal operation)	2-15S
2.2.3	Edge Emphasis	2-8S	4.4	Sleep Mode 1	2-15S
2.2.4	Editing	2-8S			
2.2.5	Density Conversion (LUT)	2-8S			

4.4.1	Shift from Standby Mode to Sleep Mode 1	2-16S	4.5.3	Shift from Sleep Mode 2 to Sleep Mode 1	2-17S
4.4.2	Shift from Sleep Mode 1 to Standby Mode	2-16S	4.6	Turning Off the Power	2-17S
4.5	Sleep Mode 2	2-17S	5	New Functions	2-18S
4.5.1	Shift from Standby Mode to Sleep Mode 2	2-17S	5.1	Hard Disk Spool	2-18S
4.5.2	Shift from Sleep Mode 2 to Standby Mode	2-17S	5.2	SMB Printing	2-19S
			5.3	LPD Banner	2-20S

CHAPTER 3 INSTALLATION

1	Selecting the Site of Installation	3-1S	2.11.2	Making a Check Using a Remote Host Address	3-19S
2	Unpacking and Installation	3-3S	2.12	Troubleshooting the Network	3-19S
2.1	Before Starting the Work	3-3S	2.12.1	Checking the Connection of the Network Cable	3-19S
2.2	Unpacking and Removing the Fixing Materials	3-4S	2.12.2	Making a Check Using a Loop-Back Address	3-20S
2.3	Mounting the Scanner	3-6S	2.12.3	Making a Check Using a Local Host Address	3-20S
2.4	Removing the Dummy Drum	3-6S	3	Relocating the Machine	3-21S
2.5	Supplying the Toner	3-7S	3.1	Preparing for Relocation	3-21S
2.6	Mounting the Drum Unit	3-10S	3.2	Lifting the Machine Off the Pedestal	3-22S
2.7	Stirring the Toner	3-12S	4	Installing the Card Reader-C1	3-23S
2.8	Setting the Cassette	3-13S	5	Installing the Document Tray-D2	3-26S
2.9	Checking the Images/ Operations	3-16S	6	Replacing the Drum Unit	3-27S
2.10	Connecting to the Network	3-18S			
2.11	Checking the Network Connection	3-18S			
2.11.1	Using the PING Function	3-18S			

CHAPTER 1

GENERAL DESCRIPTION

1 Specifications

1.1 Main Body

1.1.1 Type

Item	Description
Body	Desktop
Copyboard	Fixed
Light source	Xenon lamp
Lens	Lens array
Photosensitive medium	OPC drum (30-mm dia.)

T01-101-01

1.1.2 Systems

Item	Description
Reproduction	Indirect electrostatic
Charging	AC roller
Exposure	Laser
Copy density adjustment	Auto or manual
Development	Single-component toner projection
Pickup	Auto
	Front cassette (2 cassettes)
	Retard method (about 500 sheets of 80 g/m ² paper, about 550 sheets of 64 g/m ² paper)
	Manual
	Multifeeder
	Dual process method (about 50 sheets of 80 g/m ² paper)
Transfer	Roller
Separation	Static eliminator (static separation) + curvature
Cleaning	Blade
Fixing	SURF method (plane heater and fixing film)

T01-101-02

1.1.3 Functions

Item	Description	
Resolution	Reading	600dpi×600dpi
	Copying	1200dpi×600dpi
	Printer output	2400dpi×600dpi
Original type	Sheet, book 3-D object (2 kg max.)	
Maximum original size	A3/279.4×431.8mm (11"×17")	
Reproduction ratio	Direct (1:1), Reduce I (1:0.250), Reduce II (1:0.500), Reduce III (1:0.611), Reduce IV (1:0.707), Reduce III (1:1.414), Enlarge IV (1:2.000), Enlarge V (1:4.000), Enlarge VI (1:8.000), Zoom (1:0.250 to 8.000 ; 25% to 800% in 1% increments)	
Wait time	10 sec or less (at 20°C/168°F)	
First copy time	5.8 sec (book mode, cassette 1, Direct, A4/LTR, text mode)	
Continuous copying	999 copies max.	
Copy size	Cassette	A/B A3 max., A5 (vertical feed) min.
		Inch 279.4×431.8 mm (11"×17") max., STMT (vertical feed) min.
	Manual feed	AB A3 max., postcard (vertical feed) min.
		Inch 279.4×431.8 mm (11"×17") max., STMT (vertical feed) min.
Cassette 1/2	<ul style="list-style-type: none"> • Plain paper (64 to 80 g/m²):A3, B4, A4, B5, A5R, A4R, B5R, 279.4×431.8mm (11"×17"), LGL, LTR, LTRR, STMT, STMTR • Tracing paper (SM-1):A3, B4, A4, B5, A4R, B5R • Colored paper (Canon-recommended):B4, A4, A4R 	
Multifeeder	<ul style="list-style-type: none"> • Plain paper (64 to 80 g/m²):A3, B4, A4, B5, A5R, A4R, B5R, 279.4×431.8mm (11"×17"), LGL, LTR, LTRR, STMT, STMTR • Tracing paper (SM-1, GSN-75):A3, B4, A4, B5, A4R, B5R • Transparency (Canon-recommended):A4, A4R, LTR, LTRR • Colored paper (Canon-recommended):B4, A4, A4R • Postcard: Jpn (vertical feed), double-card, 4-sheet card • Label sheet (Canon-recommended):B4, A4, A4R, LTR, LTRR • Thick paper (90 to 128 g/m²):A3, B4, A4, B5, A4R, B5R, LTR, LTRR • Envelope 	

T01-101-03

Item	Description
Single-sided copying mode	<ul style="list-style-type: none"> • Plain paper (64 to 80 g/m²):A3, B4, A4, B5, A5R, A4R, B5R, A5, 279.4×431.5mm (11"×17"), LGL, LTR, LTRR, STMT, STMTR • Tracing paper (SM-1, GSN-75):A3, B4, A4, B5, A4R, B5R • Transparency (Canon-recommended):A4, A4R, LTR, LTRR • Colored paper (Canon-recommended):B4, A4, A4R • Postcard: Jpn postcard (vertical feed), double-card, 4-sheet card • Label sheet (Canon-recommended):B4, A4, A4R, LTR, LTRR • Thick paper (90 to 128 g/m²):A3, B4, A4, B5, A4R, B5R, LTR, LTRR • Envelope
Double-sided copying mode (automatic)	<ul style="list-style-type: none"> • Plain paper (64 to 80 g/m²):A3, B4, A4, B5, A5R, A4R, B5R, 279.4×431.8mm (11"×17"), LGL, LTR, LTRR, STMT, STMTR • Colored paper (Canon-recommended):B4, A4, A4R
Double-sided copying mode (multifeeder)	<ul style="list-style-type: none"> • Plain paper (64 to 80 g/m²):A3, B4, A4, B5, A5R, A4R, B5R, 279.4×431.8mm (11"×17"), LGL, LTR, LTRR, STMT, STMTR • Colored paper (Canon-recommended):B4, A4, A4R • Postcard: Jpn (vertical feed), double-card, 4-sheet card • Thick paper (90 to 128 g/m²):A3, B4, A4, B5, A4R, B5R, LTR, LTRR

T01-101-04

Item	Description	
Cassette	Capacity	55 mm deep (approx.; about 500 sheets of 80 g/m ² paper)
Hard disk		6GB
Non-image width	Leading edge	Direct, Enlarge/Reduce:4.0±1.5/-1.0mm <4.5±1.8mm>*1
	Trailing edge	Direct, Enlarge/Reduce:2.0±1.5mm <2.0±1.8mm>*1
	Left/right (1st side)	Direct, Enlarge/Reduce:2.5±1.5mm <2.5±2.0mm>*1
Auto clear		Yes (2 min standard; may be changed in 1-min increments between 0 and 9 min)
Sleep mode		Yes (2 min standard; may be changed in user mode to 10sec, 1, 2, 10, 15, 20, 30, 40, 50, 60, 90 min, 2, 3, or 4 hr)
Accessory		<ul style="list-style-type: none"> • DADF-H1 • Platen Cover TypeE • Document Tray-D2 • Copy Tray-F1 • Saddle Finisher-G1 • Puncher Unit-K1 (2/3holes), G1/H1 (4holes) • Finisher-J1 • Inner 2Way Tray-A1 • Paper Deck-L1 • Cassette Feeding Unit-W1 • Card Reader-C1 • Network Multi-PDL Printer Kit-C1 • Token Ring Network Interface Adapter iN-TR2

*1: The values within parentheses indicate when the DADF is used.

T01-101-05

The above specifications are subject to change for product improvement.

1.1.4 Others

Item		Description
Operating environment	Temperature range	15° to 30°C/59 to 86°F
	Humidity range	5 to 80%
	Atmospheric pressure	810.6 to 1013.3 hpa (0.8 to 1.0 atm)
Power consumption	Maximum	1350W or less
	Standby	48 W (approx.; reference only)
	Continuous	720 W (approx.; reference only)
Noise		Sound power level (Impulse mode)
	Copying	iR2200: 66 dB or less, iR3300: 71 dB or less
	Standby	iR2200: 40 dB or less, iR3300: 50 dB or less
Ozone		0.01 ppm or less avg., 0.02 ppm or less max.
Dimensions		565 (W) × 678 (D) × 1020 (H) mm
		22.2 (W) × 26.7 (D) × 40.2 (H) in (With Cassette Feeding Unit-W1)
Weight		80 kg (approx.)/176.3 lb (approx.)
Consumables	Copy paper	Keep wrapped to protect against humidity.
Toner		Keep away from direct sunshine, and keep at 40°C/85% or less.

T01-101-06

CHAPTER 1 GENERAL DESCRIPTION

Reproduction mode	Side	Paper size	copies /min (1-to-N)		
			iR2200	iR2800	iR3300
Direct	A3 (297×420mm)	A3	16	16	16
	A4 (210×297mm)	A4	22	28	33
	A5 (149×210mm)	A5	18	18	18
	B4 (257×364mm)	B4	14	14	14
	B5 (182×257mm)	B5	28	28	28
	A4R (297×210mm)	A4R	18	18	18
	B5R (257×182mm)	B5R	18	18	18
	A5R (210×149mm)	A5R	18	18	18
Reduce II (50.0%) III (61.1%) IV (70.7%) V (81.6%) VI (86.5%)	A3 → A5R	A5R	18	18	18
	A3 → B5R	B5R	18	18	18
	B4 → B5R	B5R	18	18	18
	A3 → A4R	A4R	18	18	18
	B4 → A4R	A4R	18	18	18
	B5R → A5R	A5R	18	18	18
	A4 → B5	B5	28	28	28
	A3 → B4	B4	14	14	14
Enlarge IV (200.0%) III (141.4%) II (122.4%) I (115.4%)	A5R → A3	A3	16	16	16
	A4R → A3	A3	16	16	16
	B5R → B4	B4	14	14	14
	A4R → B4	B4	14	14	14
	A5 → B5	B5	28	28	28
	B4 → A3	A3	16	16	16
	B5 → A4	A4	22	28	33

Delivery by copier, Auto paper select ON, Auto density, Non-sort, Cassette

T01-101-07

Reproduction mode	Size		(1toN)		
			iR2200	iR2800	iR3300
Direct	279.4×431.8mm (11"×17")	279.4×431.8mm (11"×17")	16	16	16
	LTR	LTR	22	28	33
	LGL	LGL	14	14	14
	LTRR	LTRR	18	18	18
	STMTR	STMTR	18	18	18
Reduce II (50.0%)	279.4×431.8mm (11"×17") → STMTR	STMTR	18	18	18
III (64.7%)	279.4×431.8mm (11"×17") → LTRR	LTRR	18	18	18
IV (73.3%)	279.4×431.8mm (11"×17") → LGL	LGL	14	14	14
V (78.6%)	LGL → LTRR	LTRR	18	18	18
Enlarge IV (200.0%)	STMTR* → 279.4×431.8mm (11"×17")	279.4×431.8mm (11"×17")	16	16	16
III (129.4%)	LTRR → 279.4×431.8mm (11"×17")	279.4×431.8mm (11"×17")	16	16	16
II (121.4%)	LGL → 279.4×431.8mm (11"×17") Paper size	279.4×431.8mm (11"×17") copies/min	16	16	16

*STMTR cannot be used as an original.

Delivery by copier, Auto paper select ON, Auto density, Non-sort, Cassette

T01-101-08

The above specifications are subject to change for product improvement.

1.2 Side Paper Deck-L1

Item	Description
Pickup method	Retard
Paper accommodation	Front loading
Paper type (horizontal feed only)	Plain paper (65 to 80 g/m ²): A4, B5, LTR Colored paper (Canon-recommended): A4
Capacity	2,500 sheets (approx.; 80 g/m ² paper)
Paper size switch	By size guide plate/in service mode
Dimensions	324 (W) × 591 (D) × 432 (H) mm 12.8 (W) × 23.3 (D) × 17.0 (H) in
Weight	30 kg (approx.)/66.1 lb (approx.)
Power supply	None (DC power supplied by accessories power supply of host machine)
Operating conditions	Same as host machine

T01-102-01

The above specifications are subject to change for product improvement.

2 Names of Parts

2.1 External View

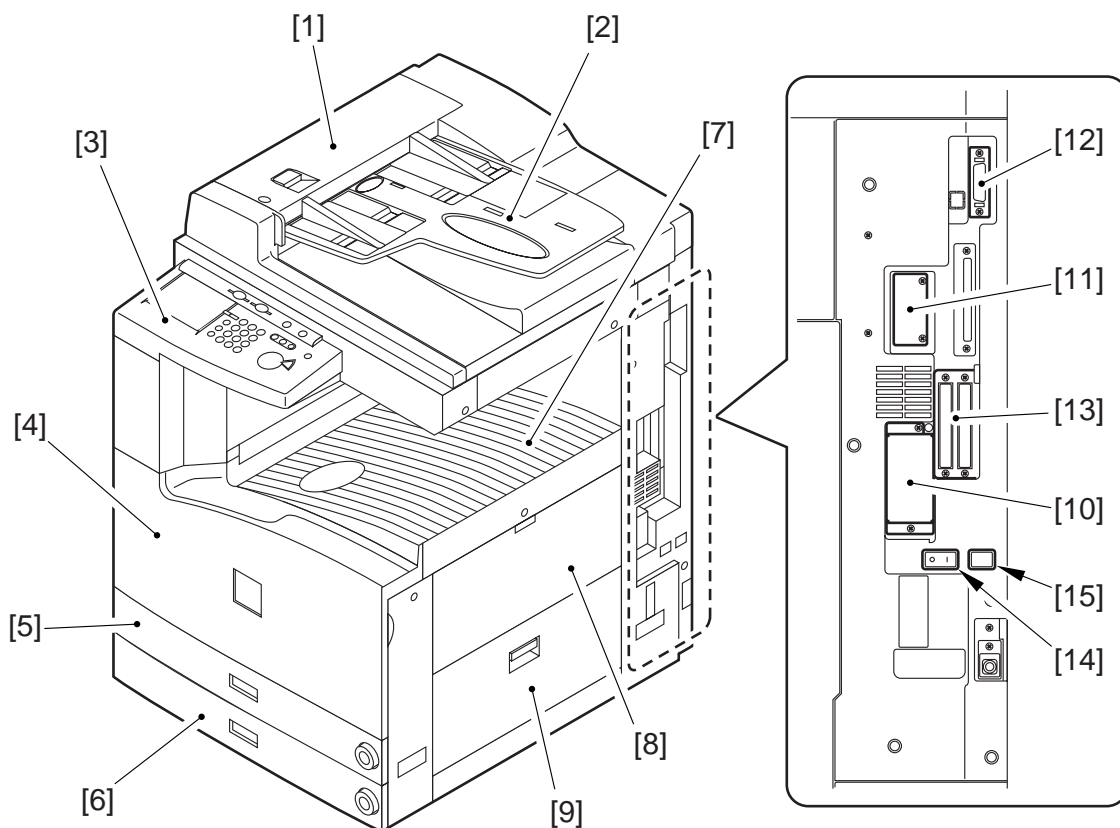

- [1] ADF
- [2] Original tray
- [3] Control panel
- [4] Front cover
- [5] Cassette 1
- [6] Cassette 2
- [7] Delivery tray
- [8] Multifeder

- [9] Right lower cover
- [10] DIMM ROM replacement cover
- [11] Network card slot
- [12] Parallel connector
- [13] Extension board slot
- [14] Main power switch
- [15] Cassette heater switch

F01-201-01

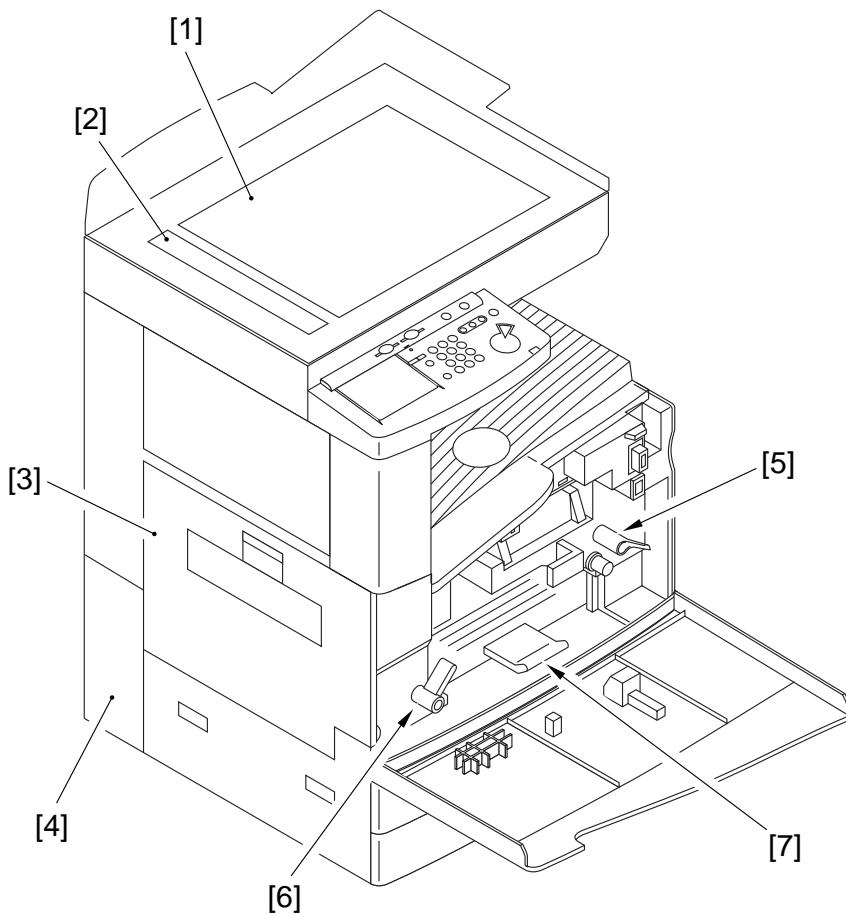

- [1] Copyboard glass
- [2] DADF reading glass
- [3] Left cover
- [4] Left lower rear cover (waste toner case cover)

- [5] Developing assembly releasing lever
- [6] Feeding assembly releasing lever
- [7] Duplex feeding assembly releasing lever

F01-201-02

2.2 Cross Section

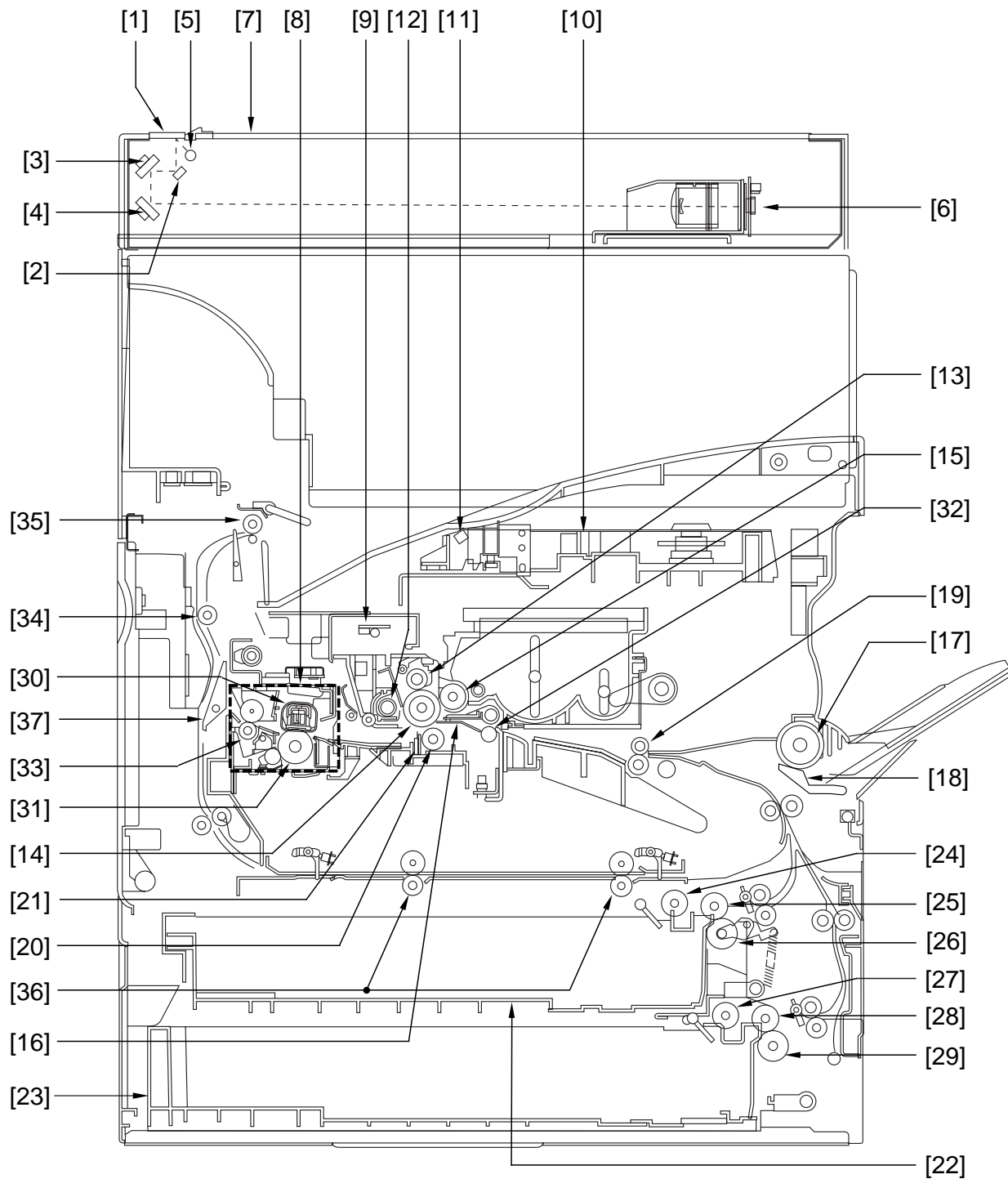

F01-202-01

- | | |
|---------------------------------|-----------------------------------|
| [1] DADF reading glass | [20] Transfer roller |
| [2] No. 1 mirror | [21] Static eliminator |
| [3] No. 2 mirror | [22] Cassette 1 |
| [4] No. 3 mirror | [23] Cassette 2 |
| [5] Scanning lamp | [24] Cassette 1 pickup roller |
| [6] CCD unit | [25] Cassette 1 feeding roller |
| [7] Copyboard glass | [26] Cassette 1 separation roller |
| [8] Fixing assembly | [27] Cassette 2 pickup roller |
| [9] Pre-exposure lamp | [28] Cassette 2 feeding roller |
| [10] Laser unit | [29] Cassette 2 separation roller |
| [11] Laser mirror | [30] Fixing film |
| [12] Drum cleaner assembly | [31] Lower fixing roller |
| [13] Primary charging assembly | [32] Pre-transfer roller |
| [14] Photosensitive drum | [33] Fixing delivery roller |
| [15] Developing cylinder | [34] Outside delivery roller |
| [16] Transfer guide | [35] Delivery roller |
| [17] Multifeeder pickup roller | [36] Duplexing roller |
| [18] Multifeeder separation pad | [37] Reversing frapper |
| [19] Registration roller | |

T01-202-01

3 System Configuration

3.1 Functional Construction

The machine may be broadly divided into the following six functional blocks:

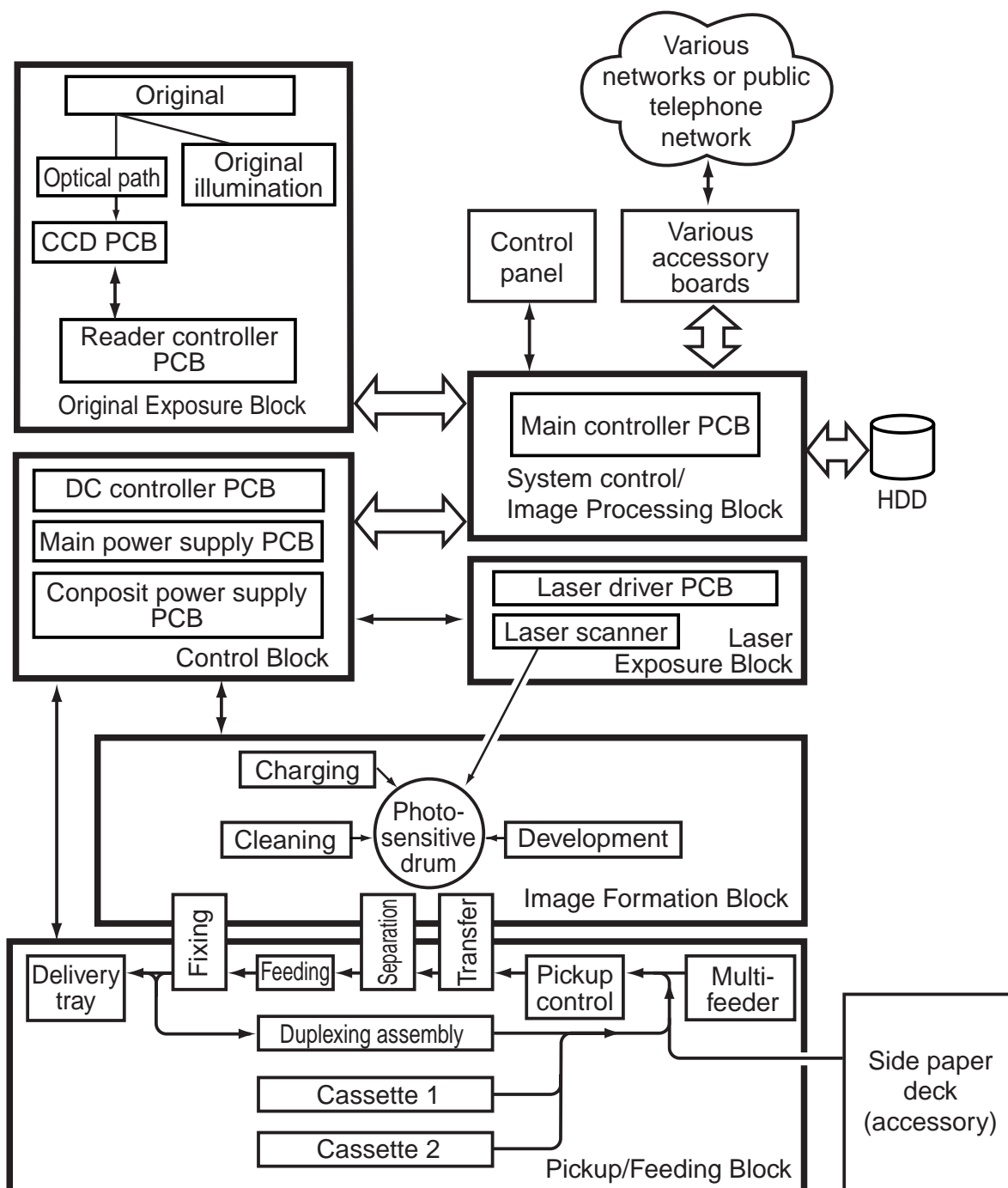

F01-301-01

3.2 Outline of the Electrical Circuitry

3.2.1 Construction of the Electrical Circuit

The major electrical mechanisms of the machine are controlled by the following PCBs:

- [1] Man controller PCB; controls the system as a whole, processes images
- [2] DC controller PCB; controls the printer unit, controls the finisher communication
- [3] Reader controller PCB; controls the reader unit, controls the DADF communication

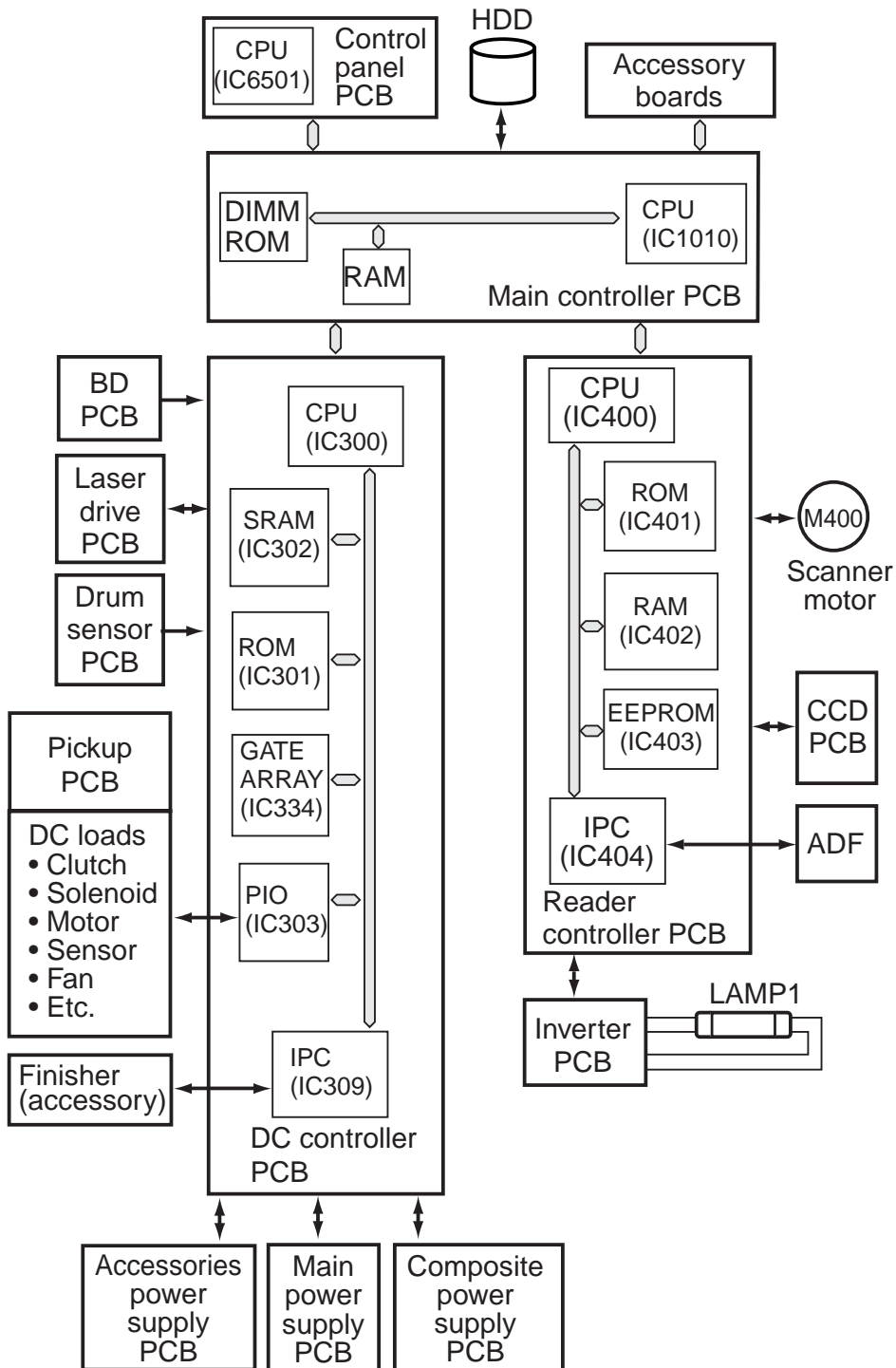

F01-302-01

3.3 Inputs to and Outputs from the Major PCBs

3.3.1 Wiring Diagram of the Major PCBs

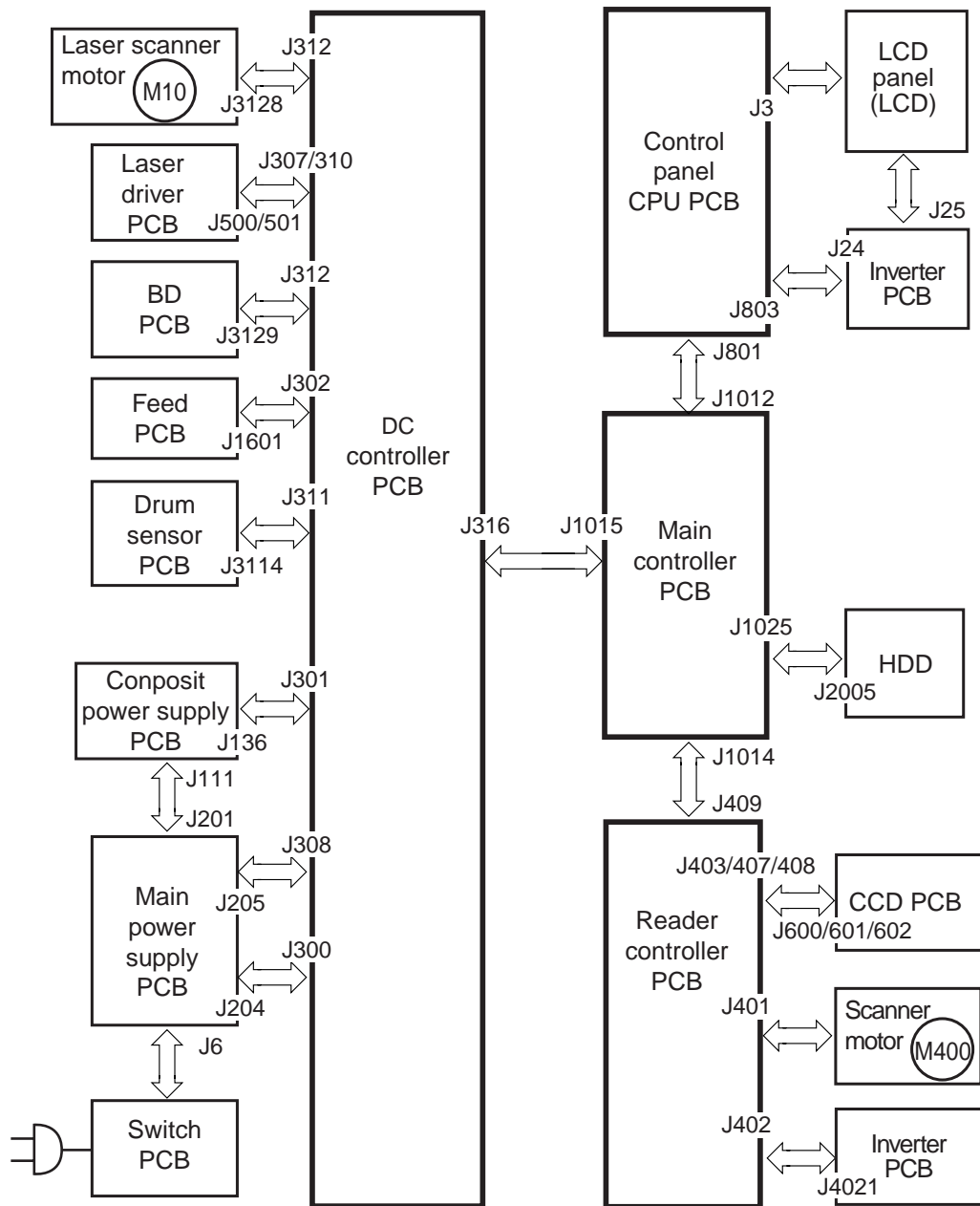

Note: The \longleftrightarrow in the diagram indicates connection between PCBs, NOT the flow of signals.

F01-303-01

3.4 Configuration with Accessories

3.4.1 Accessories for Original/Paper Feeding

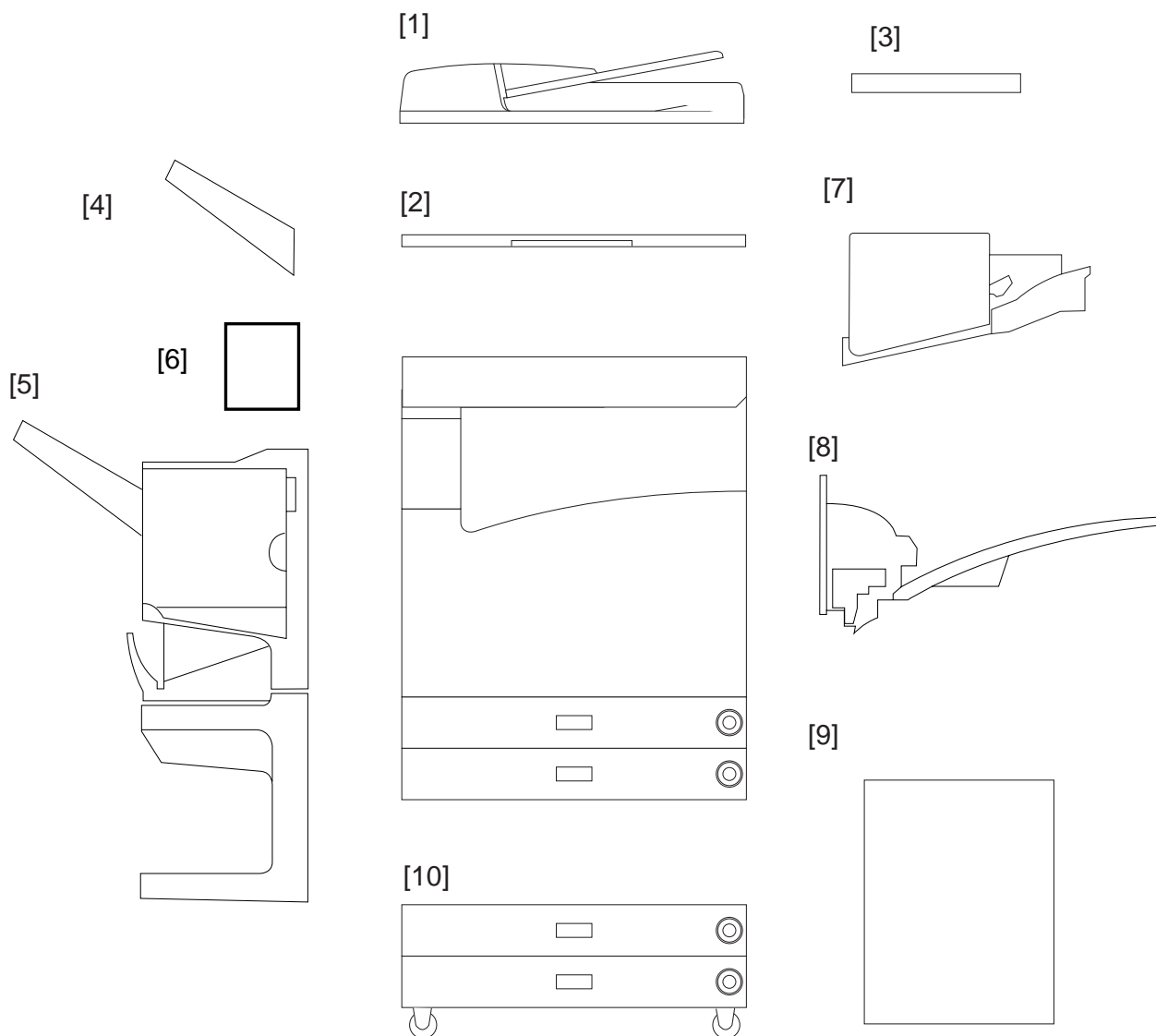

- [1] DADF-H1
- [2] Platen Cover TypeE
- [3] Document Tray-D2
- [4] Copy Tray-F1
- [5] Saddle Finisher-G1

- [6] Puncher Unit-K1/G1/H1
- [7] Finisher-J1
- [8] Inner 2way Tray-A1
- [9] Paper Deck-L1
- [10] Cassette Feeding Unit-W1

F01-304-01

3.4.2 Accessory Boards

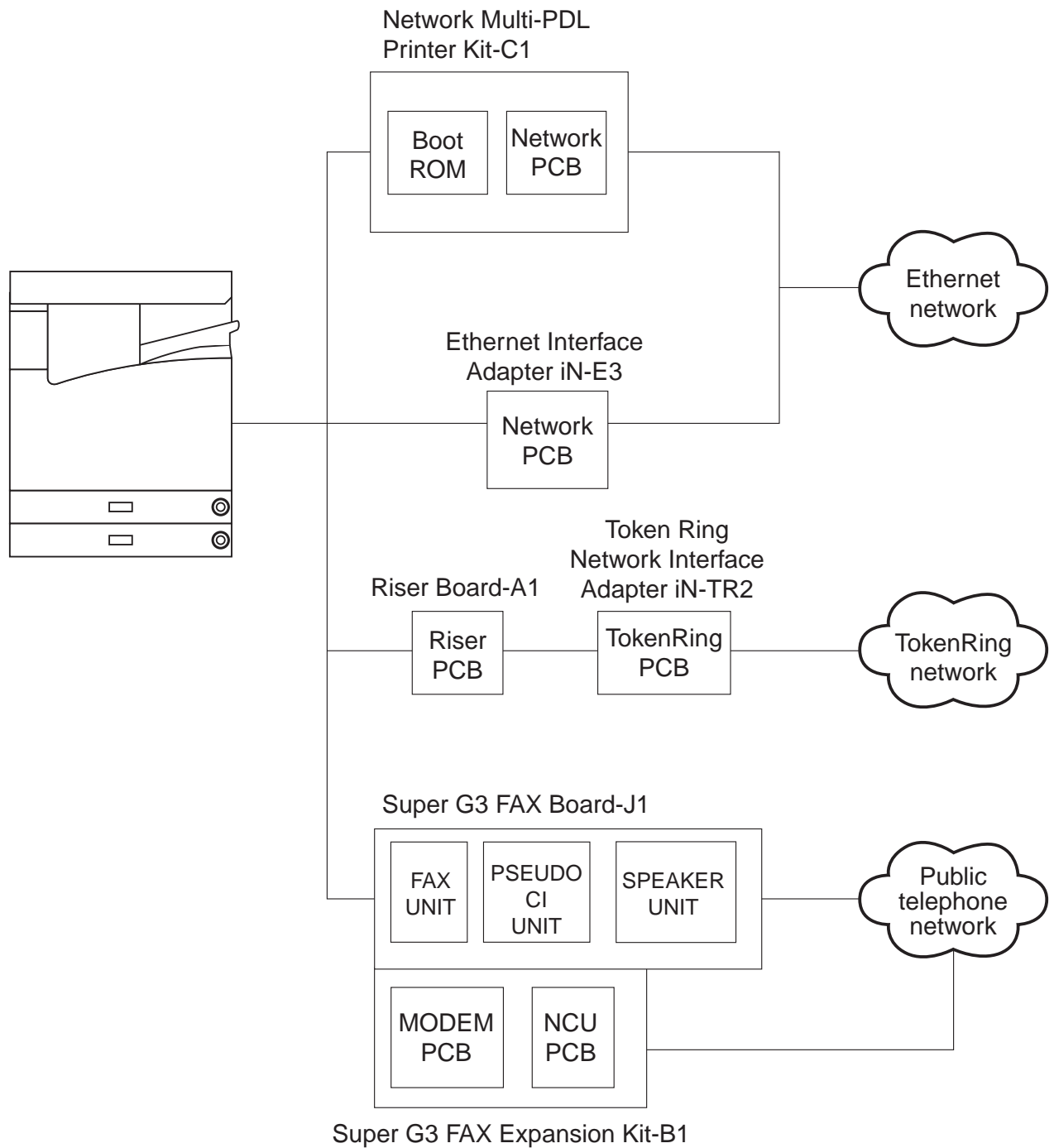

F01-304-02

Product: 2001 Canon iR2200/iR2800/iR3300 Printer Service Repair Workshop Manual
Full Download: <https://www.arepairmanual.com/downloads/2001-canon-ir2200ir2800ir3300-printer-service-repair-workshop-manual/>

Sample manual. Download All pages at:
<https://www.arepairmanual.com/downloads/2001-canon-ir2200ir2800ir3300-printer-service-repair-workshop-manual/>