

Product: 1999 Canon NP6317 Printer Service Repair Workshop Manual
Full Download: <https://www.arepairmanual.com/downloads/1999-canon-np6317-printer-service-repair-workshop-manual/>

NP6317

SERVICE MANUAL

REVISION 0

The Canon logo is centered at the bottom of the page. It consists of the word "Canon" in a bold, sans-serif font, with a distinctive red dot above the letter 'o'.

APR. 1999

FY8-13G5-000

Sample of manual. Download All 248 pages at:

<https://www.arepairmanual.com/downloads/1999-canon-np6317-printer-service-repair-workshop-manual/>

COPYRIGHT © 1999 CANON INC.

CANON NP6317 REV.0 APR. 1999 PRINTED IN JAPAN (IMPRIME AU JAPON)

IMPORTANT

THIS DOCUMENTATION IS PUBLISHED BY CANON INC., JAPAN, TO SERVE AS A SOURCE OF REFERENCE FOR WORK IN THE FIELD.

SPECIFICATIONS AND OTHER INFORMATION CONTAINED HEREIN MAY VARY SLIGHTLY FROM ACTUAL MACHINE VALUES OR THOSE FOUND IN ADVERTISING AND OTHER PRINTED MATTER.

ANY QUESTIONS REGARDING INFORMATION CONTAINED HEREIN SHOULD BE DIRECTED TO THE COPIER SERVICE DEPARTMENT OF THE SALES COMPANY.

THIS DOCUMENTATION IS INTENDED FOR ALL SALES AREAS, AND MAY CONTAIN INFORMATION NOT APPLICABLE TO CERTAIN AREAS.

COPYRIGHT © 1999 CANON INC.

Printed in Japan

Imprimé au Japon

Use of this manual should be strictly supervised to avoid disclosure of confidential information.

Prepared by

OFFICE IMAGING PRODUCTS TECHNICAL SUPPORT DEPARTMENT 3
OFFICE IMAGING PRODUCTS TECHNICAL SUPPORT DIVISION
OFFICE IMAGING PRODUCTS QUALITY ASSURANCE CENTER

CANON INC.

5-1, Hakusan 7-chome, Toride-shi, Ibaraki 302-8501 Japan

Sample of manual. Download All 248 pages at:

<https://www.arepairmanual.com/downloads/1999-canon-np6317-printer-service-repair-workshop-manual/>

INTRODUCTION

This Service Manual contains basic data and figures for the Stapler Sorter-J1/K1/E3 needed to service the machine in the field.

- Chapter 1 *General Description* introduces the copier's features and specifications, shows how to operate the copier, and explains how copies are made.
- Chapter 2 *Basic Operation* provides outlines of the copier's various operational workings.
- Chapter 3 *Exposure System* discusses the principles of operation used for the copier's lens drive unit and scanner drive unit. It also explains the timing at which these drive units are operated, and shows how they may be disassembled/assembled and adjusted.
- Chapter 4 *Image Formation System* discusses the principles of how images are formed. It also explains the timing at which the various units involved in image formation are operated, and shows how they may be disassembled/assembled and adjusted.
- Chapter 5 *Pick-Up/Feeding System* explains the principles used from when copy paper is picked up to when a copy is delivered in view of the functions of electrical and mechanical units and in relation to their timing of operation. It also shows how these units may be disassembled/assembled and adjusted.
- Chapter 6 *Fixing System* explains the principles used to fuse toner images to transfer media in view of the functions of electrical and mechanical units and in relation to their timing of operation. It also shows how these units may be disassembled/assembled and adjusted.
- Chapter 7 *Externals/Auxiliary Mechanisms* shows the copier's external parts, and explains the principles used for the copier's various control mechanisms in view of the functions of electrical and mechanical units and in relation to their timing of operation. It also shows how these units may be disassembled/assembled and adjusted.
- Chapter 8 *Installation* introduces requirements for the site of installation, and shows how the copier may be installed using step-by-step instructions.
- Chapter 9 *Maintenance and Servicing* provides tables of periodically replaced parts and consumables/durables and scheduled servicing charts.
- Chapter 10 *Troubleshooting* provides tables of maintenance/inspection, standards/adjustments, and problems identification (image fault/malfunction).

Appendix contains diagrams showing electrical parts arrangement, tables of signals, tables of special tools, tables of solvents/oils, and a general timing chart.

The descriptions in this Service Manual are subject to change without notice for product improvement or other purposes, and major changes will be communicated in the form of Service Information bulletins.

All service persons are expected to have a good understanding of the contents of this Service Manual and all relevant Service Information bulletins and be able to identify and isolate faults in the machine.

CONTENTS

CHAPTER 1 GENERAL DESCRIPTION

I. FEATURES	1-1	B. Cross Section	1-6
II. SPECIFICATIONS	1-2	IV. OPERATION	1-8
A. Type	1-2	A. Control Panel	1-8
B. System	1-2	B. Daily Inspection to Be Performed by the User	1-10
C. Performance	1-2	V. IMAGE FORMATION	1-11
D. Others	1-3	A. Outline	1-11
III. NAMES OF PARTS	1-5		
A. External View	1-5		

CHAPTER 2 BASIC OPERATION

I. BASIC OPERATION	2-1	D. DC Controller Outputs	2-6
A. Functions	2-1	E. Basic Sequence of Operations (Direct, Continuous Copying (2 sheets))	2-9
B. Outline of Electric Circuitry ...	2-2		
C. Inputs to DC Controller	2-4		

CHAPTER 3 EXPOSURE SYSTEM

I. BASIC OPERATION	3-1	D. Scanner Movement for Two-Page Separation Mode (copy count "2")	3-7
A. Changing the Reproduction Ratio	3-1	IV. No. 4/5 MIRROR DRIVE SYSTEM	3-8
II. LENS DRIVE SYSTEM	3-2	V. DISASSEMBLY AND ASSEMBLY	3-11
A. Outline	3-2	A. Lens Drive Assembly	3-11
B. Basic Lens Drive System Operation (change of reproduction ratio)	3-3	B. Scanner Drive Assembly	3-14
III. SCANNER DRIVE SYSTEM	3-4	C. Exposure Assembly	3-17
A. Outline	3-4	D. Blank Assembly	3-19
B. Relation Between Scanner Sensor and Signals	3-5	E. No. 4/5 Mirror Mount	3-20
C. Basic Scanner Operation	3-6		

CHAPTER 4 IMAGE FORMATION SYSTEM

I. PROCESSES 4-1	B. Operation 4-9
A. Outline 4-1	V. DOCUMENT DENSITY
B. Basic Operation of Image Formation System (black developing assembly, 2 copies) 4-2	MEASUREMENT SYSTEM 4-11
II. CONTROLLING THE SCANNING LAMP 4-3	A. Outline 4-11
A. Outline 4-3	B. Operation 4-11
B. Mechanism 4-4	C. Reading the Output of the AE Sensor 4-12
III. PRIMARY/TRANSFER CORONA CURRENT AND GRID BIAS VOLTAGE CONTROL SYSTEM 4-5	D. Adjustment 4-13
A. Outline 4-5	VI. DEVELOPING ASSEMBLY/ DRUM CLAENER 4-14
B. Switching Primary/Transfer Corona Current ON/OFF 4-5	A. Outlines 4-14
C. Maintaining Primary/Transfer Corona Current Constant 4-6	B. Remaining Toner Sensor 4-14
D. Controlling Grid Bias Voltage 4-7	C. Torque Limiter 4-15
IV. CONTROLLING DEVELOPING BIAS 4-8	VII. BLANKING 4-16
A. Outline 4-8	A. Outline 4-16
	B. Movement of the Blank Exposure Mechanism 4-17
	VIII. DISASSEMBLY AND ASSEMBLY 4-19
	A. Main Motor Assembly 4-19
	B. Corona System 4-20
	C. Primary/Transfer Corona Assembly 4-22
	D. Development System 4-25

CHAPTER 5 PICK-UP/FEEDING SYSTEM

I. PAPER PICK-UP ASSEMBLY AND FEEDER 5-1	A. Pick-up Assembly Delay Jam 5-8
A. Outline 5-1	B. Delivery Assembly Stationary Jam 5-9
B. Pick-up and Feeder Operation 5-3	C. Delivery Assembly Delay Jam 5-10
C. Identifying the Paper Size 5-4	III. FEEDER SYSTEM 5-11
D. Pick-Up from the Mulfifeeder 5-5	A. Pick-up Assembly 5-11
II. JAM DETECTION 5-7	B. Feeder Assembly 5-17

CHAPTER 6 FIXING SYSTEM

- | | |
|---|--|
| I. BASIC OPERATIONS6-1 | III. DISASSEMBLY AND ASSEMBLY6-4 |
| A. Outline6-1 | A. Fixing Assembly6-4 |
| B. Operation of Fixing Assembly Temperature Control System6-3 | |

CHAPTER 7 EXTERNALS/AUXILIARY MECHANISMS

- | | |
|---------------------------------------|-----------------------------|
| I. POWER SUPPLY7-1 | A. External Covers7-4 |
| A. AC Driver DC Power Supply7-1 | B. Control Panel7-7 |
| II. DISASSEMBLY AND ASSEMBLY7-3 | C. Copyboard Cover7-9 |
| | D. Fans7-9 |
| | E. PCBs7-11 |

CHAPTER 8 INSTALLATION

- | | |
|--|---|
| I. LOCATION8-1 | E. Checking the Image8-7 |
| II. UNPACKING AND INSTALLING THE COPIER8-2 | F. Universal Cassette Code Setting "123"8-8 |
| A. Unpacking8-2 | III. RELOCATING THE COPIER8-9 |
| B. Mounting the Drum8-4 | IV. INSTALLING THE CONTROL CARD-V8-10 |
| C. Checking the Operation8-5 | |
| D. Adding Toner8-6 | |

CHAPTER 9 MAINTENANCE AND SERVICING

- | | |
|---|--|
| I. PERIODICALLY REPLACED PARTS9-1 | III. BASIC PROCEDURE FOR PERIODIC SERVICING9-3 |
| II. DURABLE PARTS9-2 | IV. PERIODIC SERVICING SCHEDULE9-4 |

CHAPTER 10 TROUBLESHOOTING

I. MAINTENANCE AND INSPECTION	10-1	V. TROUBLESHOOTING FEEDING PROBLEMS	10-56
A. Basic Image Adjustment Procedure	10-1	A. Paper Jams	10-56
B. Points to Check for Periodic Maintenance	10-2	VI. INCORRECT PAPER FEED OPERATION	10-60
II. STANDARDS AND ADJUSTMENT	10-3	VII. FUNCTION AND ARRANGEMENT OF THE ELECTRICAL PARTS	10-62
A. Mechanical	10-3	A. Sensors, Fuses and Lamps	10-62
B. Electrical	10-17	B. Clutches, Solenoids, Fans, Motors and Heaters	10-63
III. IMAGE TROUBLESHOOTING	10-21	C. Switches, Circuit Breakers, Counters, Etc.	10-64
A. Initial Check	10-21	D. PCBs	10-65
B. Samples of Image Faults	10-24	VIII. SERVICE MODE	10-66
C. Troubleshooting of Image Faults	10-25	A. Outline	10-66
IV. OPERATION TROUBLESHOOTING	10-37	B. Using the Service Mode ...	10-66
A. Troubleshooting of Malfunction	10-37	C. Guide to Service Mode ...	10-67
		IX. SELF DIAGNOSIS	10-69

APPENDIX

A. GENERAL TIMING CHART	A-1	C. GENERAL CIRCUIT DIAGRAM	A-5
B. LIST OF SIGNALS/ ABBREVIATIONS	A-3	D. SOLVENTS AND OILS LIST	A-7

CHAPTER 1

GENERAL DESCRIPTION

I. FEATURES	1-1	B. Cross Section	1-6
II. SPECIFICATIONS	1-2	IV. OPERATION	1-8
A. Type	1-2	A. Control Panel	1-8
B. System	1-2	B. Daily Inspection to Be Performed by the User	1-10
C. Performance	1-2	V. IMAGE FORMATION	1-11
D. Others	1-3	A. Outline	1-11
III. NAMES OF PARTS	1-5		
A. External View	1-5		

I. FEATURES

1. **Copies as large as A3 in size (DIRECT) may be made, and the copyboard is of a fixed type.**
 - Although compact in design, the copier enables making copies as large as A3 in size in the DIRECT mode.
 - The copyboard is of a fixed type so that pages of a book may be copied with much ease.
2. **Zooming between 50% and 200%.**
 - Copies may be made in reproduction ratios of between 50% and 200%, selectable in 1% increments.
3. **Front loading for faster supply of paper.**
 - Paper is loaded from the front of the copier so that the cassette* may be replenished with paper without wasting time. The design also saves space.
 - * Universal and its capacity is 500 sheets.
4. **Single-component fine particle toner for high resolution.**
 - Images are developed using the single component toner projection method. Further, the copier uses toner of extremely fine particles for enhanced image quality.
5. **Multifeeder (stack bypass) pick-up.**
 - As many as 50 copies (80 g/m²) may be made continuously using the multifeeding mechanism.
6. **Low warm-up time**
 - The copier warms up in than 25 sec.

II. SPECIFICATIONS

A. Type

Body	Desktop
Copyboard	Fixed
Light source	Halogen lamp
Lens	Single lens + mirror movement
Photosensitive medium	OPC

B. System

Reproduction	Indirect electrostatic method	
Charging	Corona	
Exposure	Slit (moving light source)	
Copy density adjustment	Auto or manual	
Development	Dry	
Pick-up	Automatic	Exclusive cassette
	Manual	Multifeeder
Transfer	Corona	
Separation	Curvature and Static eliminator	
Drum cleaning	Blade	
Fixing	Heat roller (900W)	

C. Performance

Type of document	Sheet, Book, 3-D object (2 kg)	
Document size	A3 max.	
Wait time	25 sec (approx.; at 20°C)	
First copy	9.4 sec (A4, AE ON/OFF, 1:1)	
Continuous copying	99 copies	
Type of copy paper	Cassette	A3 (max.), A6 (min.; 148x105 mm)
	Multifeed tray	Plain paper (64 to 80 g/m ²), Tracing paper, Colored paper Plain paper (64 to 128 g/m ²), Tracing paper*, Colored paper, OHP film*, Label sheet

* Use of tracing paper may cause double feeding. If thin paper or OHP film, feed one sheet at a time.

Two-sided copying	Multifeed tray	Plain paper (64 to 128 g/m ²), Colored paper
Overlay copying	Multifeed tray	Plain paper (64 to 128 g/m ²), Colored paper
Cassette	Claw	Provided
	Standard	60 mm deep (about 500 sheets of 80 g/m ² paper)
	Universal	Yes
Copy tray		100 sheets (approx.; A4, 80 g/m ²)
Non-image width (1st side)	Leading edge	2.0 ±1.5 mm or less
	Left/Right	2.5 ±1.5 mm or less
Auto clear		Provided (2 min, standard)
Auto shutoff		Yes
Option		ADF-A1, MS-A1, Stapler Sorter D3, CC-V

D. Others

Power supply		Serial Numbers	
	230V 50Hz	UFW xxxxx	
	230V 50Hz	QFE xxxxx	
Power consumption	Maximum	1.5kW or less	
Noise	Copying	55 dB or less	(sound power level as prescribed by ISO) 0.05ppm or less (UL standards)
	Standby	40 dB or less	
Ozone		0.05 ppm or less (UL standards)	
Dimensions	Width	610 mm	
	Depth	617 mm	
	Height	416 mm	
Weight		50 kg or less	
Operating environment	Temperature	15.0° to 30°C	
	Humidity	5% to 80%	
	Atmospheric pressure	0.6m to 1	
Others		Keep copy paper wrapped to protect against moisture.	

Reproduction mode		Paper size	Cassette	Copies/min
DIRECT		A3 (297x420mm)	A3	9
		A4 (210x297mm)	A4	17
		B4 (257x365mm)	B4	10
		B5 (182x257mm)	B5	17
		A5R (210x149mm)	A5R	16
REDUCE	I	50%		
	II	A3 → A4	A4R	10
ENLARGE	I	A4 → A3	A3	9
	II	200%		

III. NAMES OF PARTS

A. External View

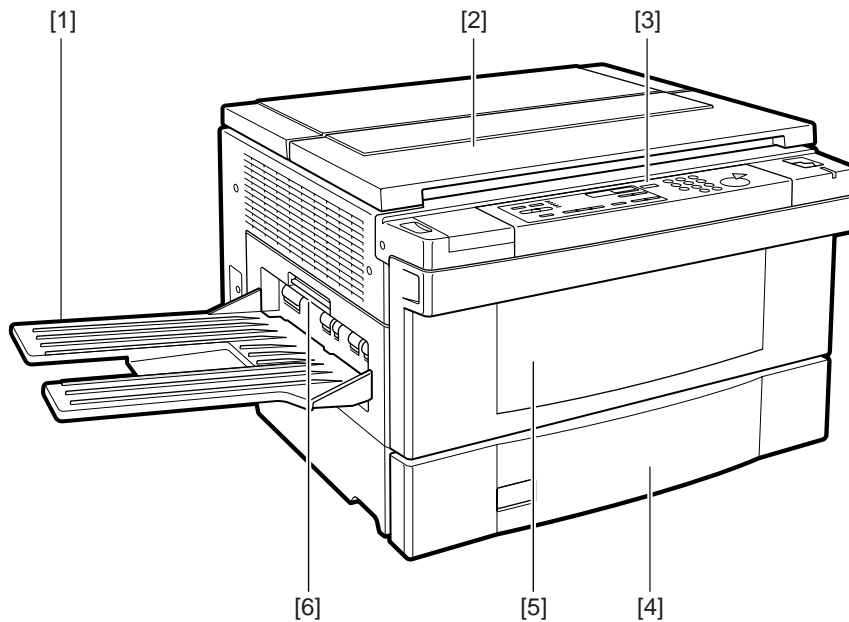

- [1] Copy tray
- [2] Copyboard cover
- [3] Control panel
- [4] Cassette
- [5] Front cover
- [6] Delivery cover

Figure 1-301

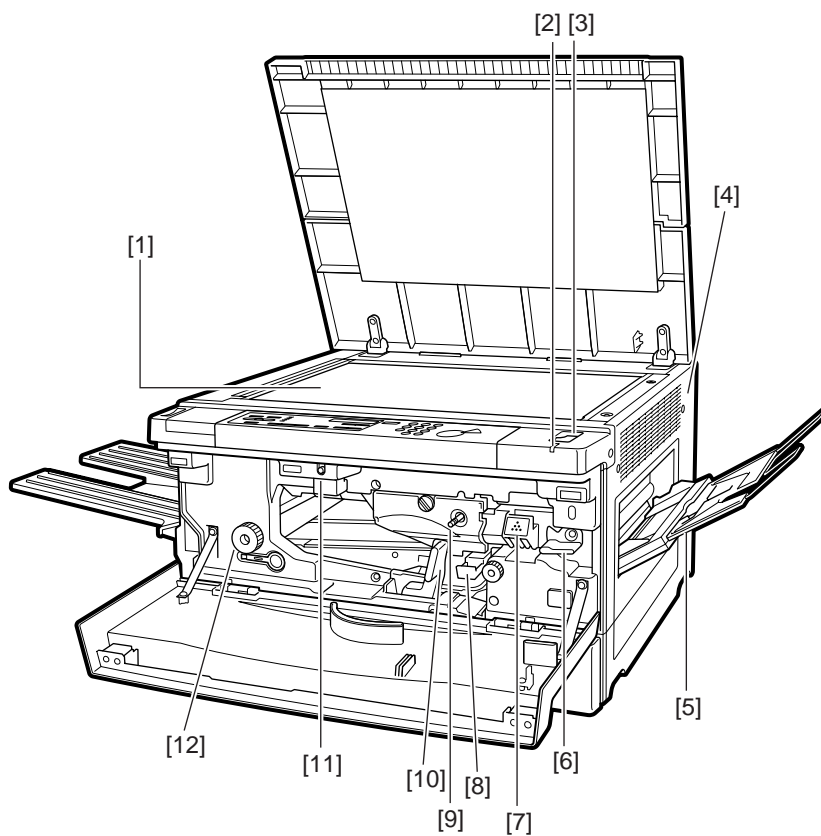

- [1] Copyboard glass
- [2] Power indicator
- [3] Power switch
- [4] Right cover
- [5] Multifeder tray
- [6] Developing assembly release lever
- [7] Developing assembly
- [8] Transfer/separation assembly
- [9] Primary corona assembly cleaner
- [10] Feeder assembly release lever
- [11] Copy density knob
- [12] Fixing assembly knob

Figure 1-302

B. Cross Section

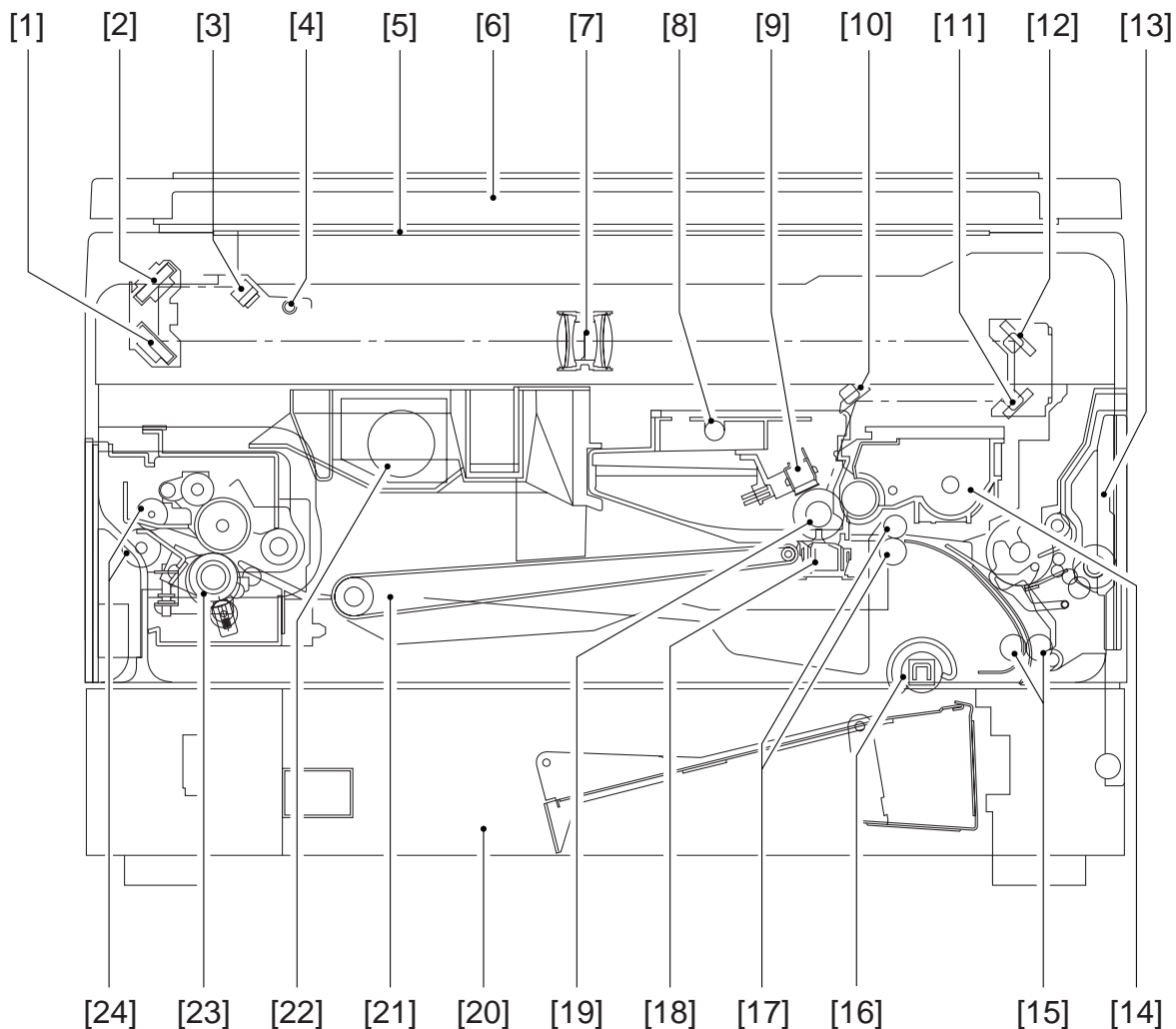

- | | | |
|-----------------------------|-------------------------------|--------------------------|
| [1] No. 3 mirror | [10] No. 6 mirror | [19] Photosensitive drum |
| [2] No. 2 mirror | [11] No. 5 mirror | [20] Cassette |
| [3] No. 1 mirror | [12] No. 4 mirror | [21] Feeder assembly |
| [4] Scanning lamp | [13] Multifeder tray | [22] Exhaust fan |
| [5] Copyboard glass | [14] Developing assembly | [23] Fixing assembly |
| [6] Copyboard cover | [15] Feeder roller 1 | [24] Delivery roller |
| [7] Lens | [16] Pick-up roller | |
| [8] Pre-exposure lamp | [17] Registration roller | |
| [9] Primary corona assembly | [18] Transfer corona assembly | |

Figure 1-303

Blank Page

IV. OPERATION

A. Control Panel

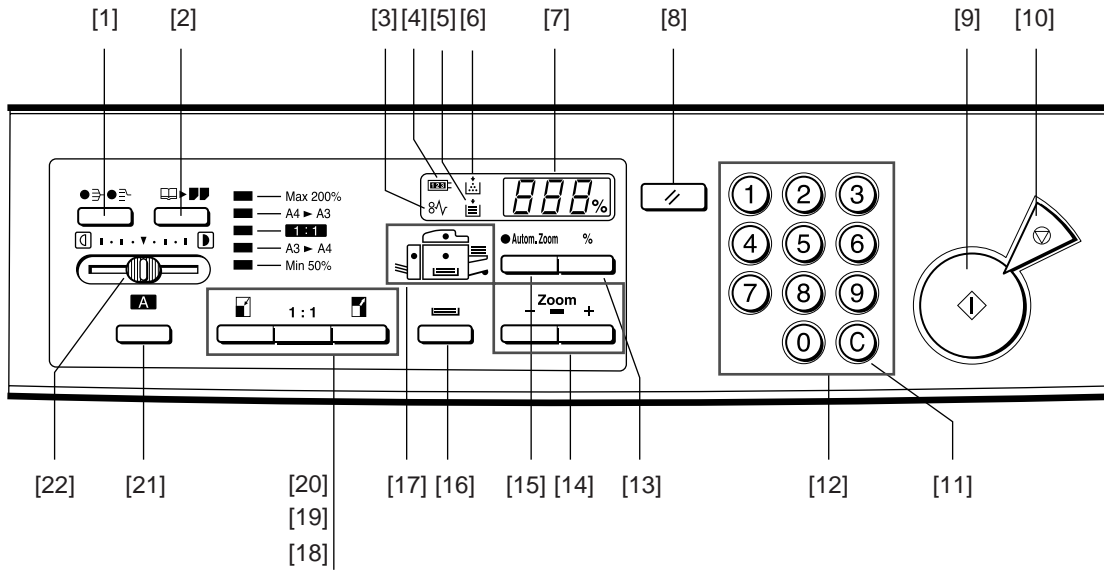

Figure 1-401

No.	Name	Description
[1]	Sort/Group key	Press to select or cancel the Sort or Group mode. * To use the Sort or Group mode, your copier must be equipped with the optional Sorter or Stapler Sorter.
[2]	Two-Page Separation key	Press to select or cancel the Two-Page Separation mode.
[3]	Paper Jam indicator	Flashes when a paper jam occurs.
[4]	Control Card Check indicator	Flashes when the Control Card is not fully inserted.
[5]	Paper Out indicator	Flashes when there is no paper in the selected paper supply (paper cassette or stack bypass).
[6]	Toner Out indicator	Flashes when toner needs to be added.
[7]	Copy quantity/Copy ratio display	Displays the number of copies to be made, and the selected enlargement/reduction ratio. Also, when the copier is not functioning properly, the Service Call message will appear here.
[8]	Reset key	Press to return the copier to the Standard mode.
[9]	Start key	Press to begin copying.
[10]	Stop key	Press to stop the copier before copying is complete.
[11]	Clear key	Press to change the number of copies to be made to one.
[12]	Number keys	Press to input the number of copies to be made.
[13]	Percent key	Press to display the selected enlargement/reduction ratio.
[14]	Zoom keys	Press to reduce or enlarge copy images by any ratio from 50% to 200%, selectable in 1% increments.
[15]	Autom. Zoom key	Press to select or cancel Automatic Zoom. * To use Automatic Zoom, your copier must be equipped with the optional Automatic Document Feeder (ADF). When copying using the stack bypass or a universal cassette, you cannot use Automatic Zoom.
[16]	Paper Select key	Press to select the paper supply (paper cassette or stack bypass).
[17]	Paper Supply/Jam Location indicator	Lights to show the selected paper supply (paper cassette or stack bypass). If a paper jam occurs, flashes to show jam location. * This indicator will also flash to inform the user of various errors.
[18]	Enlarge key	Press to enlarge copy images using a fixed enlargement ratio.
[19]	1:1 (Direct) Copy key	Press to make copies the same size as the original.
[20]	Reduce key	Press to reduce copy images using a fixed reduction ratio.
[21]	AE (Automatic Exposure) key	Press to select or cancel Automatic Exposure Control.
[22]	Exposure lever	Use to manually adjust the lightness/darkness of copies.

B. Daily Inspection to Be Performed by the User

Carefully instruct the user to be sure to clean the following parts of the copier once a week.

1. Primary Corona Assembly

Slide in and out the wire cleaner to clean the corona wires.

2. Copyboard Glass

Clean the copyboard glass with a moist cloth; then, wipe it dry.

3. Copyboard Cover

Clean the copyboard cover with a mild detergent solution; then, wipe it dry.

4. Transfer Corona Assembly

Remove the transfer corona assembly from the copier; then, slide the knob (wire cleaner) at the bottom of the transfer corona assembly back and forth to clean the corona wires.

Further, clean the static eliminator using the cleaning brush (accessory).

V. IMAGE FORMATION

A. Outline

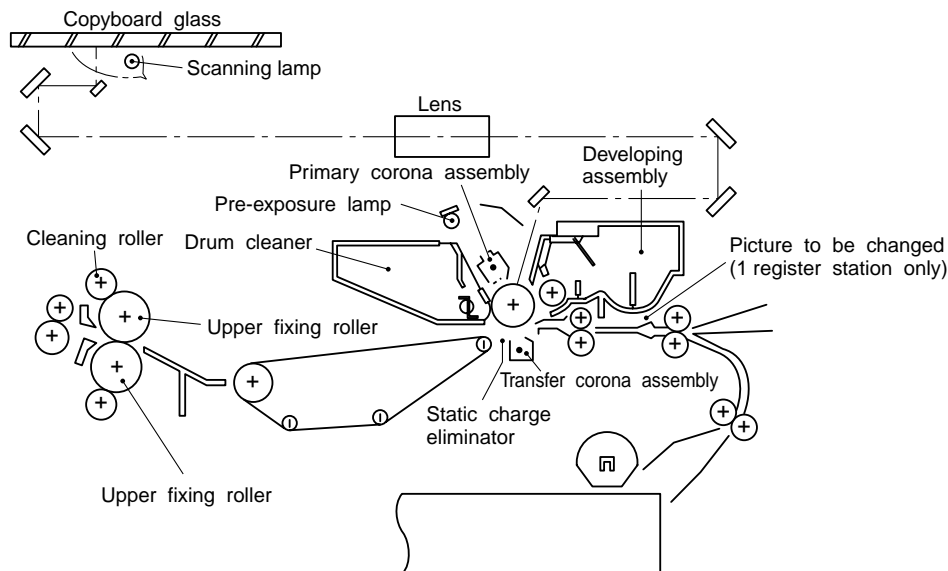

Figure 1-501

This copier consists of the units shown in Figure 1-501.

The image forming process is divided into the eight steps shown below.

- Step 1: Pre-exposure
- Step 2: Primary corona (negative DC)
- Step 3: Image exposure
- Step 4: Developing (positive plus AC)
- Step 5: Transfer (negative DC)
- Step 6: Separation
- Step 7: Fixing
- Step 8: Drum cleaning

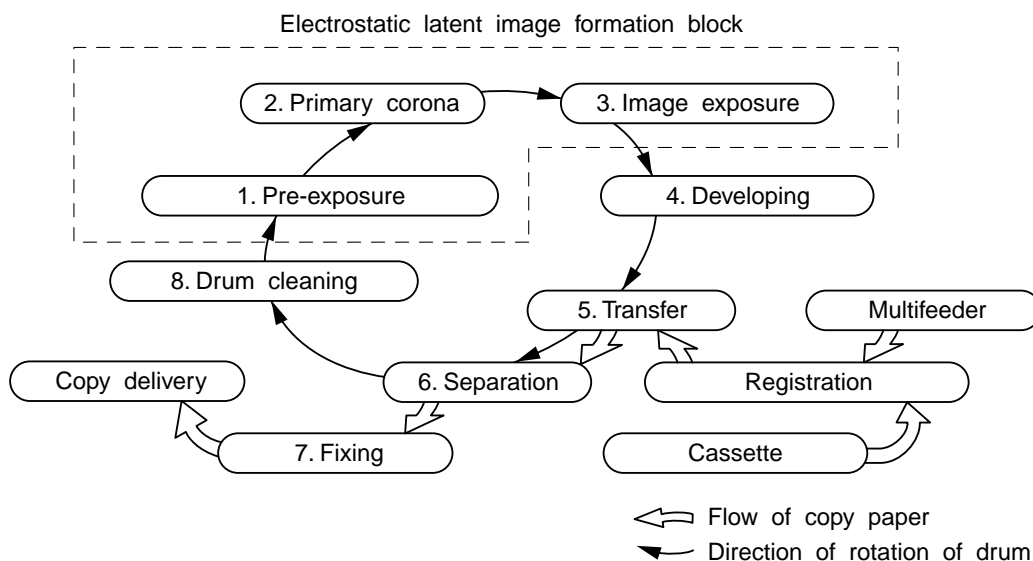



Figure 1-502

CHAPTER 2

BASIC OPERATION

In outline diagrams,  represents mechanical drive paths, and  indicates electrical signal paths.

Signals in digital circuits are identified as '1' for High and '0' for Low. The voltage of signals, however, depends on the circuit.

Nearly all operations of the product are controlled by a microprocessor; the internal workings of the processor are not relevant to the serviceman's work and, therefore, are left out of the discussions. By the same token, no repairs are prescribed for the PCBs at the user's premises; for this reason, PCBs are discussed by means of block diagrams rather than circuit diagrams.

For the purpose of explanation, discussions are divided into the following: from sensors to DC controller PCB input ports; from DC controller output ports to loads; and minor control circuits and functions.

I. BASIC OPERATION	2-1	D. DC Controller Outputs	2-6
A. Functions	2-1	E. Basic Sequence of Operations	
B. Outline of Electric Circuitry ...	2-2	(Direct, Continuous Copying	
C. Inputs to DC Controller	2-4	(2 sheets))	2-9

I. BASIC OPERATION

A. Functions

The copier can be divided into four functional sections: paper pick-up and feed system, exposure system, image formation system, and control system.

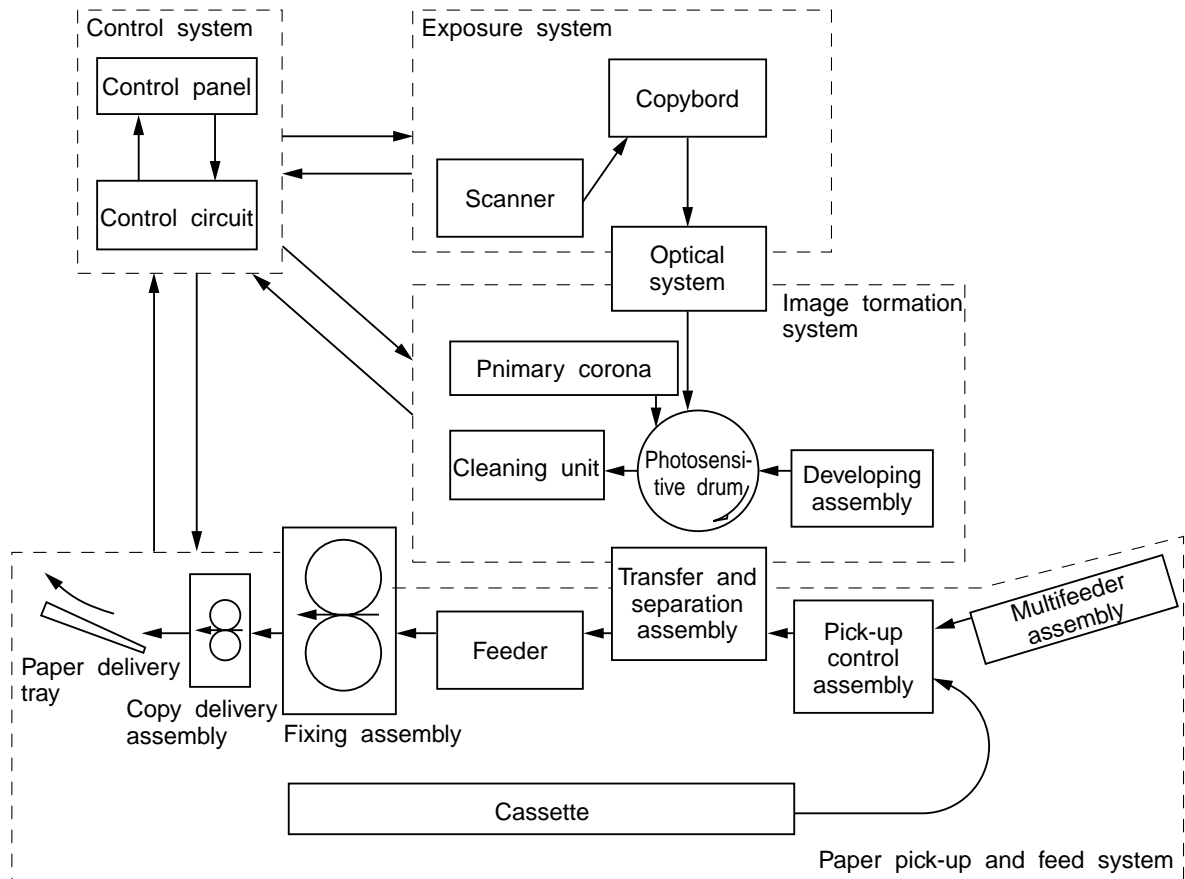

Figure 2-101

B. Outline of Electric Circuitry

The NP-6317's main mechanisms are controlled by the microprocessor, PROM, and EEPROM on the DC controller PCB.

1. Microprocessor (Q300)

- controls the copying sequence
- controls the control panel
- controls the main motor/scanner motor/mirror motor
- controls the scanning lamp/fuser lamp
- reads the analog signals

2. PROM (Q301)

- contains the sequence program

3. EEPROM (Q317)

- stores data that can be modified in the service mode (replaces conventional variable resistors and switches)

Note: _____

EEPROM is a type of ROM in which data may be erased or stored newly.
For this reason, the NP-6317's RAM and RAM are not backed up by a lithium battery.

Note: _____

The NP-6317 is equipped with an A/D converter and, therefore, its microprocessor can read analog signals.

Note: _____

The main motor (M1) is a brushless motor.
The scanner motor (M2) and mirror motor (M3) are stepping motors which use the oscillation frequency of the crystal oscillator on the DC controller.

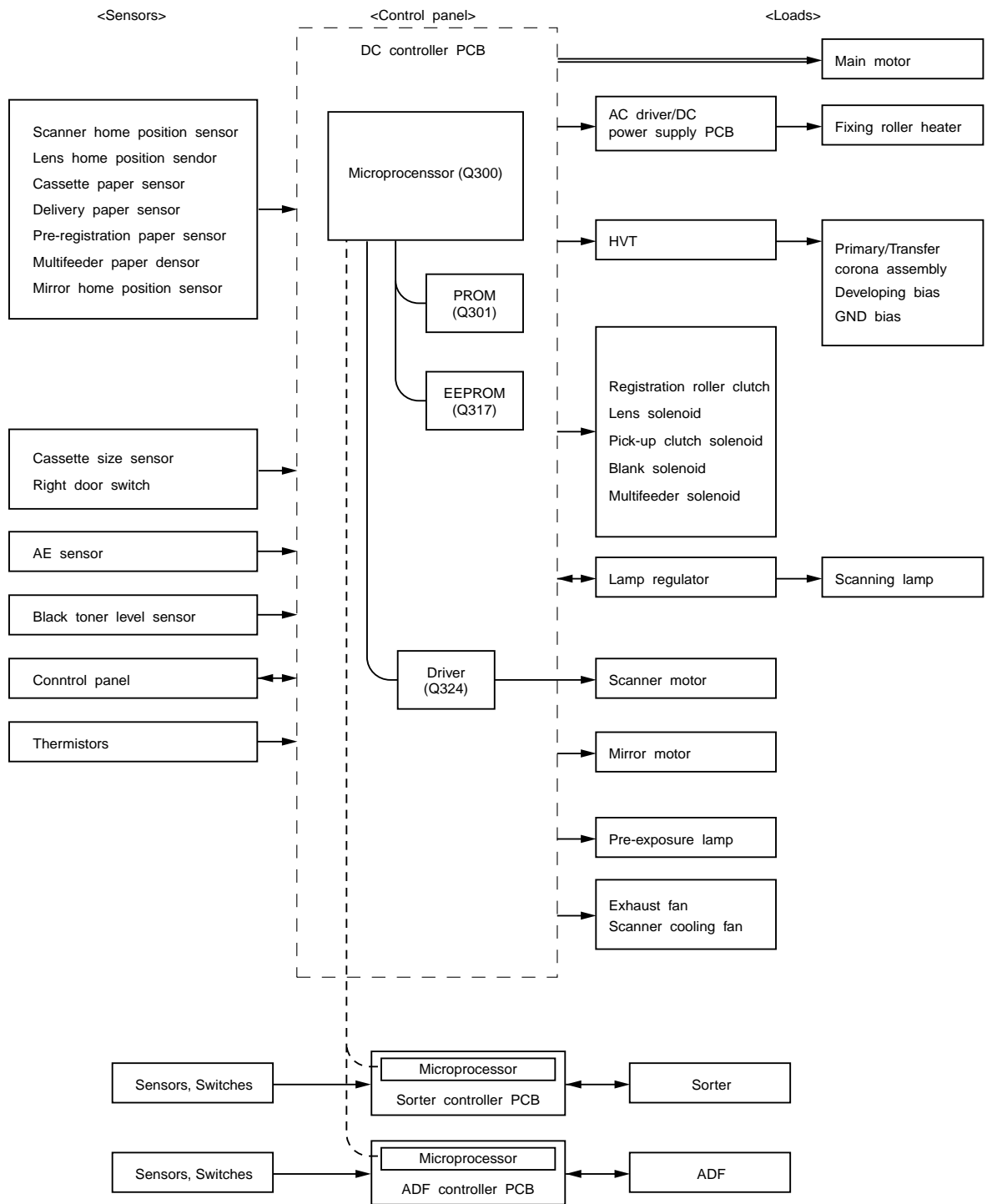

Figure 2-102

C. Inputs to DC Controller

1. Inputs to DC Controller (1/2)

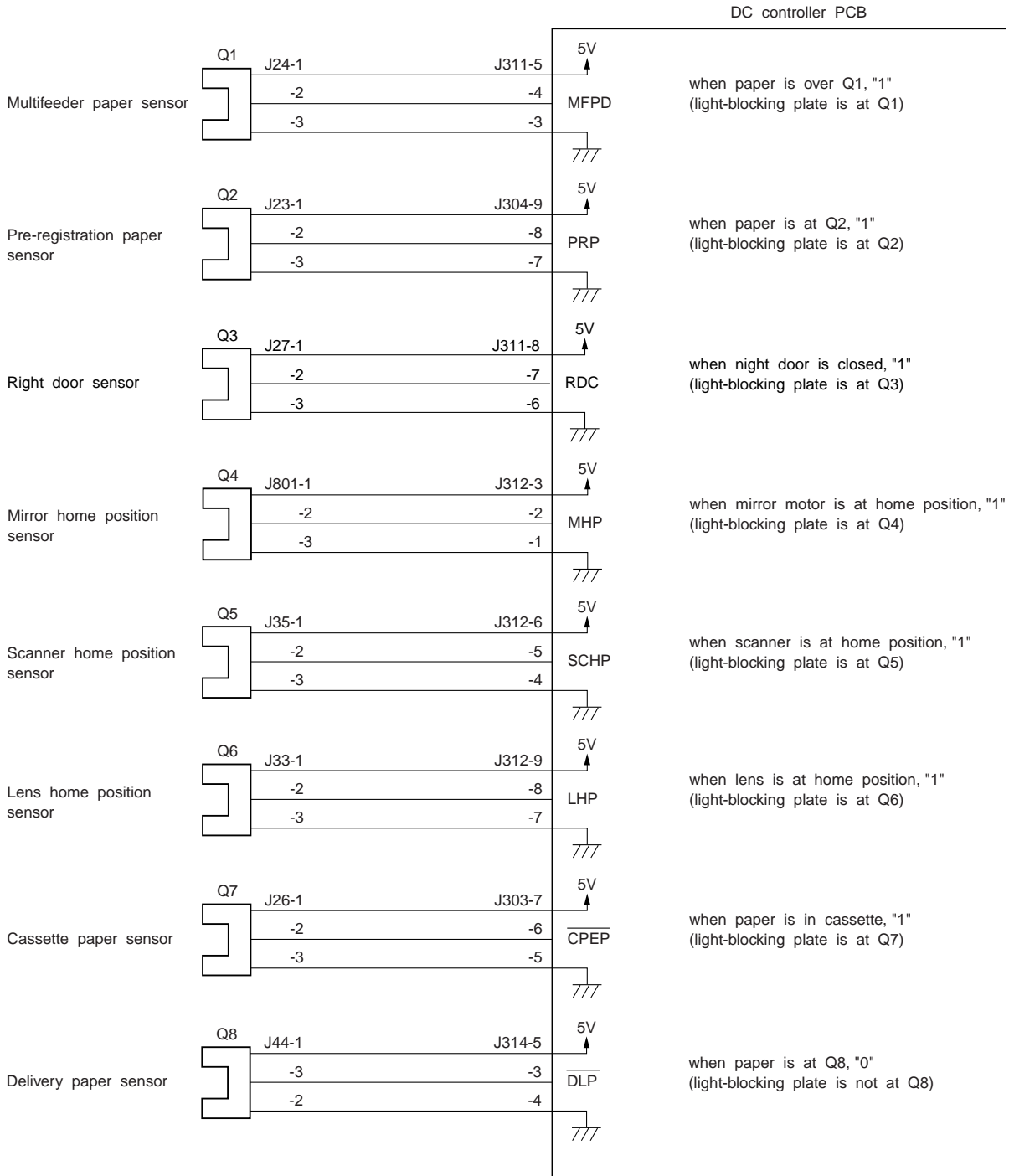

Figure 2-103

2. Inputs to DC Controller (2/2)

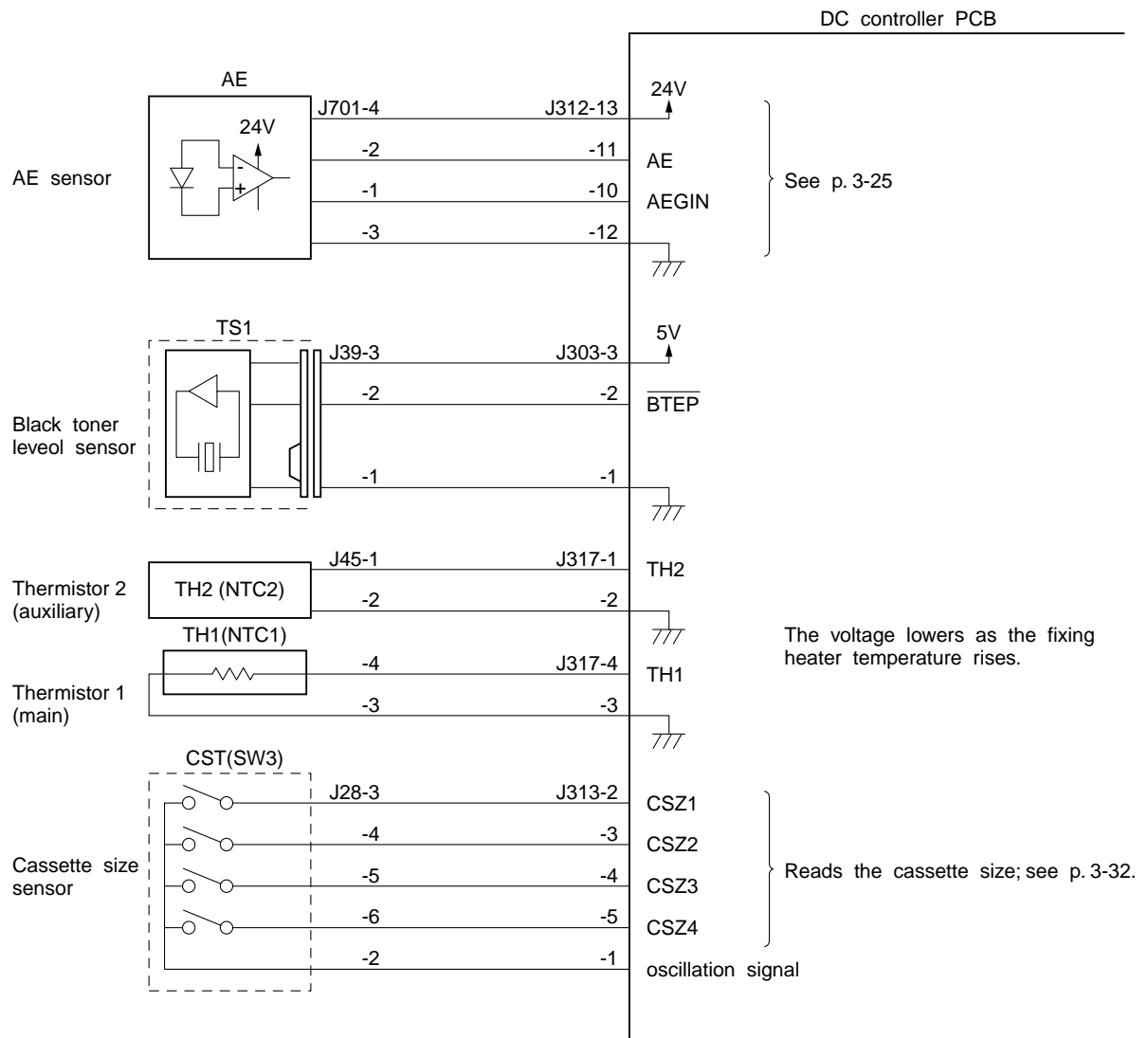

Figure 2-104

D. DC Controller Outputs

1. DC Controller Out Puts (1/3)

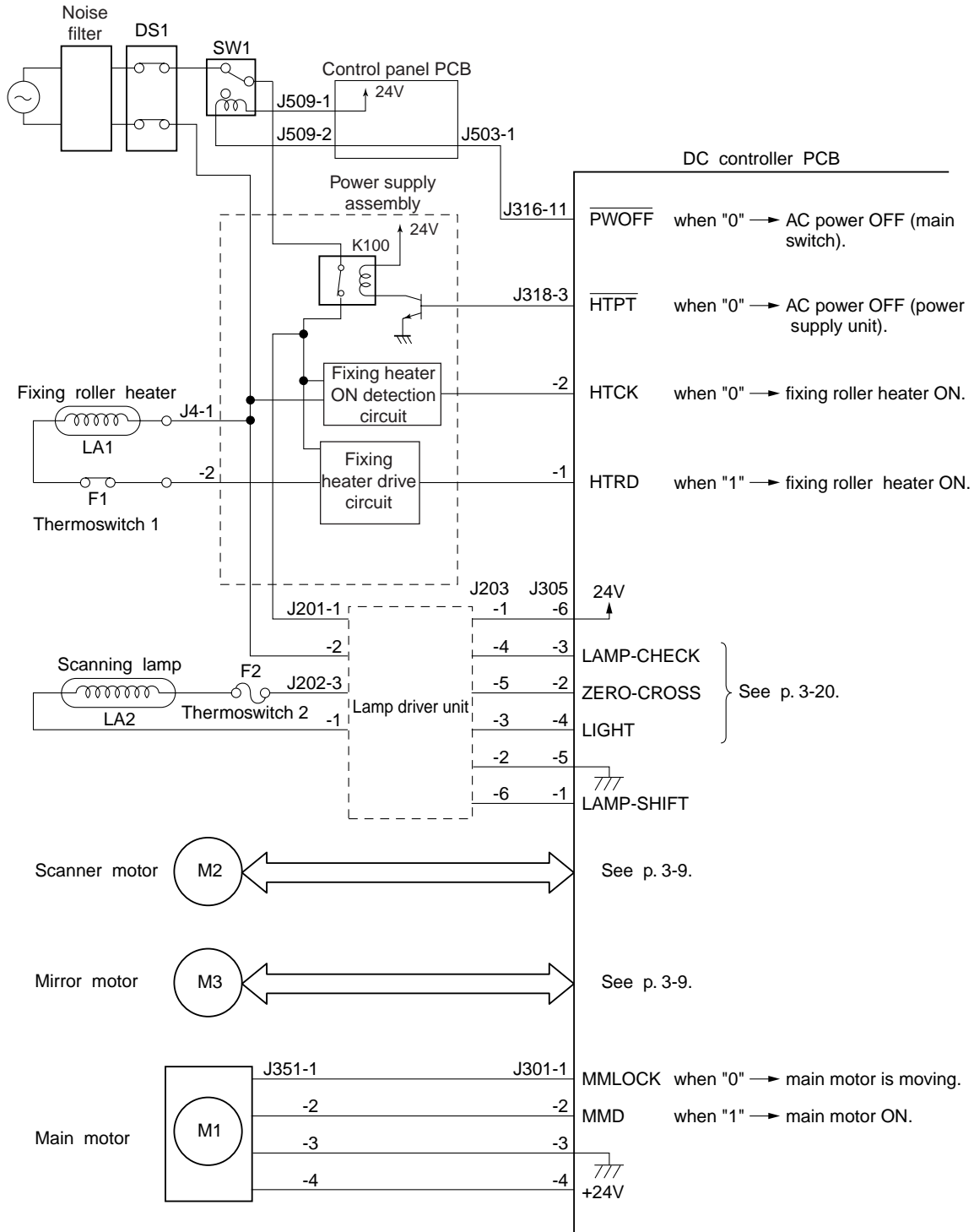

Figure 2-105